

V1.1-2026-02-03

Residential All-In-One Energy Storage System

ESA 5-30kW

GW5.1-BAT-D-G20

GW8.3-BAT-D-G20

GW5.1-BAT-D-G21

GW8.3-BAT-D-G21

Solutions Manual

GOODWE

Copyright Statement

Copyright Statement

Copyright© GoodWe Technologies Co., Ltd. 2026. All rights reserved.

Without the authorization of GoodWe Technologies Co., Ltd., no part of this manual may be reproduced, distributed, or uploaded to third-party platforms such as public networks in any form.

Trademark Authorization

GOODWE and other GOODWE trademarks used in this manual are owned by GoodWe Technologies Co., Ltd. All other trademarks or registered trademarks mentioned in this manual belong to their respective owners.

NOTICE

Due to product version upgrades or other reasons, the content of this document is updated periodically. Unless otherwise agreed, the content of this document cannot replace the safety precautions on the product label. All descriptions in the document are for guidance only.

About This Manual

Overview

This document primarily introduces the product information, installation wiring, configuration and commissioning, troubleshooting, and maintenance content for the energy storage system composed of inverters, Battery system, and smart meters. Please read this manual carefully before installing and using the product to understand the product safety information and familiarize yourself with the product's functions and features. The document may be updated periodically; please obtain the latest version of the materials and more product information from the official website.

Applicable Model

The energy storage system includes the following products:

Product Type	Product Information	Description
Inverter	GW5K-ETA-G20 GW6K-ETA-G20 GW8K-ETA-G20 GW9.999K-ETA-G20 GW10K-ETA-G20 GW12K-ETA-G20 GW15K-ETA-G20 GW20K-ETA-G20 GW25K-ETA-G20 GW29.999K-ETA-G20 GW30K-ETA-G20	Nominal output power: 5kW-30kW

Product Type	Product Information	Description
Battery system	GW5.1-BAT-D-G20 GW5.1-BAT-D-G21	Rated energy 5.12kWh
	GW8.3-BAT-D-G20 GW8.3-BAT-D-G21	Rated energy 8.32kWh
Meter	GMK330 GM330	Monitoring module in the energy storage system, capable of detecting operating voltage, current, and other information in the system.
smart dongle	WiFi/LAN Kit-20	Can upload system operation information to the monitoring platform via WiFi or LAN signals.

Symbol Definition



 DANGER
Indicates a highly potential danger that, if not avoided, will result in death or serious injury.
 WARNING
Indicates a moderately potential danger that, if not avoided, may result in death or serious injury.
 CAUTION
Indicates a low potential danger that, if not avoided, may result in moderate or minor injury.
NOTICE
Emphasizes and supplements the content, and may also provide tips or tricks for optimizing product use, helping you solve a problem or save your time.

Table of Contents

1 Safety Precautions	9
1.1 General Safety	9
1.2 personnel requirements	10
1.3 System Safety	11
1.3.1 PV String Safety	13
1.3.2 Inverter Safety	14
1.3.3 Battery Safety	15
1.3.4 Smart Meter Safety	18
1.4 Safety Symbols and Certification Marks	18
1.5 EU Declaration of Conformity	20
1.5.1 Equipment with Wireless Communication Modules	20
1.5.2 No Equipment with Wireless Communication Modules (except Battery)	20
1.5.3 Battery	21
2 System Introduction	22
2.1 System Overview	22
2.2 Product Overview	33
2.2.1 Residential All-in-One System	33
2.2.2 Smart Meter	39
2.2.3 smart dongle	40
2.3 Supported Grid Types	41
2.4 System Working Mode	41

2.5 Features	51
3 Check and Storage	55
3.1 Check Before Receiving	55
3.2 deliverables	55
3.2.1 Inverter Deliverables	55
3.2.2 Batteries Deliverables	58
3.2.2.1 Cluster Expansion Basedeliverables	59
3.2.2.2 Wall-Mounted Bracket	61
3.2.3 Smart Meter DeliverablesGM330 & GMK330	61
3.2.3.1 Attachment List	61
3.3 Storage	62
4 Installation	65
4.1 Installation Requirements	65
4.1.1 Installation Environment Requirements	65
4.1.2 Installation Space Requirements	67
4.1.3 Tool Requirements	68
4.2 Equipment Handling	70
4.3 Installation equipment	71
4.4 Installing the Smart Meter	77
5 System Wirings	78
5.1 System Wiring Electrical Block Diagram	79
5.2 Detailed System Wiring Diagram	83

5.3 Preparing Materials	93
5.3.1 Preparing Breakers	94
5.3.2 Preparing Cables	97
5.4 Connecting the PE cable	99
5.5 Connecting the PV Cable	100
5.6 Connecting the Battery Cable	102
5.7 Connecting the AC Cable	103
5.8 Connecting the Meter Cable	105
5.9 Connecting the Inverter Communication Cable	107
6 System Commissioning	113
6.1 Check Before Power ON	113
6.2 Power ON	113
6.3 Installation Protective cover	116
6.4 Indicators	116
6.4.1 Inverter Indicators	116
6.4.2 Battery Indicators	119
6.4.3 Smart Meter Indicator GM330 & GMK330	119
6.4.3.1 indicator Description	119
6.4.4 Smart Dongle Indicator	120
7 System Commissioning	123
7.1 Set Inverter parameters via the App	123
7.1.1 Download the Installation SEMS+ App	123

7.2 Power Plant Monitoring is performed via SEMS+ WEB	124
8 Maintenance	125
8.1 Power OFF the System	125
8.2 Removing the Equipment	126
8.3 Disposing of the Equipment	127
8.4 Routine Maintenance	127
8.5 fault	131
8.5.1 Viewing Fault/Alarms Information	131
8.5.2 Fault Information and Troubleshooting	131
8.5.2.1 Inverter fault	133
8.5.2.2 Batteryfault	203
9 technical parameter	222
9.1 Inverter Parameters	222
9.2 Battery Technical Data	247
9.3 Smart Meter Technical Data	250
9.3.1 GM330	250
9.3.2 GMK330	251
9.4 Smart Dongle Technical Data	252
9.4.1 WiFi/LAN Kit-20	252
10 Appendix	254
10.1 FAQ	254
10.1.1 How to perform Meter/CT Auxiliary Detection?	254

10.1.2 How to Upgrade the Device Version.....	254
10.2 Abbreviations.....	255
10.3 Explanation of Terms.....	258
10.4 Battery SN code meaning.....	259
11 Contact Information.....	261

1 Safety Precautions

The safety precautions information contained in this document must always be followed when operating the device.

WARNING

The device has been strictly designed and tested in accordance with safety regulations, but as an electrical device, before performing any operations on the device, relevant safety instructions must be followed. Improper operation may lead to serious injury or property damage.

1.1 General Safety

NOTICE

- Due to product version upgrades or other reasons, the document content will be updated periodically. Unless otherwise agreed, the document content cannot replace the safety precautions on product labels. All descriptions in the document are for guidance only.
- Please read this document carefully before installing the device to understand the product and precautions.
- All operations of the device must be performed by professional and qualified electrical technicians who are familiar with the relevant standards and safety regulations at the project location.
- When operating the device, use insulated tools and wear personal protective equipment to ensure personal safety. When handling electronic components, wear anti-static gloves, anti-static wrist straps, anti-static clothing, etc., to protect the device from electrostatic damage.
- Unauthorized disassembly or modification may cause device damage, and such damage is not covered by the warranty.
- Device damage or personal injury caused by not installing, using, or configuring the device according to the requirements of this document or the corresponding user manual is beyond the manufacturer's liability. For more product warranty information, please obtain it through the official website:
<https://en.goodwe.com/warrantyrelated.html>.

1.2 personnel requirements

NOTICE

To ensure safety, compliance, and efficiency throughout the entire process of equipment transportation, Installation, wiring, operation, and maintenance, operations must be performed by qualified personnel.

1. Qualified personnel include:
 - Personnel who have mastered knowledge of equipment working principles, system structure, risks and hazards, and have received professional operation training or possess extensive practical experience.
 - Personnel who have received relevant technical and safety training, possess certain operational experience, are aware of potential dangers specific tasks may pose to themselves, and can take protective measures to minimize risks to themselves and others.
 - Qualified electrical technicians meeting the regulatory requirements of the country/region.
 - Personnel holding a degree in electrical engineering/an advanced diploma in electrical discipline or equivalent/possessing professional qualifications in the electrical field, with at least 2/3/4 years of experience in testing and supervision work using electrical equipment safety standards.
2. Personnel involved in special tasks such as electrical work, work at heights, and special equipment operation must hold valid qualification certificates as required by the equipment's location.
3. Medium-voltage equipment operation must be performed by certified high-voltage electricians.
4. Equipment and component replacement is only permitted to be performed by authorized personnel.

1.3 System Safety



- Before performing electrical connections, disconnect all upstream switches of the device to ensure it is powered off. Working on live circuits is strictly prohibited, as it may lead to hazards such as electric shock.
- To prevent personal injury or equipment damage caused by working on live circuits, a circuit breaker must be added to the voltage input side of the device.
- All operations including transportation, storage, installation, operation, use, and maintenance must comply with applicable laws, regulations, standards, and specifications.
- The specifications of cables and components used for electrical connections must comply with local laws, regulations, standards, and specifications.
- Use the cable connectors provided in the package to connect the device cables. If other models of connectors are used, any resulting equipment damage is not within the manufacturer's liability.
- Ensure all cables of the device are correctly connected, securely fastened, and free from looseness. Improper wiring may cause poor contact or damage the equipment.
- The equipment's protective grounding wire must be firmly connected.
- To protect the equipment and its components from damage during transportation, ensure that transport personnel are professionally trained. Record the operation steps during transportation and keep the equipment balanced to avoid dropping.
- The equipment is heavy. Assign personnel according to the equipment's weight to prevent it from exceeding the human lifting capacity and causing injury from falling.
- Ensure the equipment is placed stably and not tilted. Equipment tipping over may cause equipment damage and personal injury.

 **WARNING**

- During equipment installation, avoid having the terminals bear weight, as this may cause terminal damage.
- If the cable is subjected to excessive tension, it may lead to poor connections. When wiring, leave a certain length of cable slack before connecting it to the equipment's terminal ports.
- Cables of the same type should be bundled together. Different types of cables should be routed at least 30mm apart and must not be intertwined or cross-routed.
- Using cables in high-temperature environments may cause insulation aging and damage. Maintain a distance of at least 30mm between cables and heat-generating components or the periphery of heat source areas.

1.3.1 PV String Safety

WARNING

- Ensure the component frame and mounting system are properly grounded.
- After connecting the DC cables, ensure the cable connections are tight and secure with no looseness. Improper wiring may cause poor contact or high impedance, and damage the inverter.
- Use a multimeter to measure the positive and negative poles of the DC cables to ensure correct polarity, with no reverse connection; and that the voltage is within the permissible range.
- Use a multimeter to measure the DC cables to ensure correct polarity, with no reverse connection; the voltage should be lower than the maximum DC input voltage. Damage caused by reverse connection and overvoltage is not covered by the equipment manufacturer's warranty.
- The PV string output does not support grounding. Before connecting the PV string to the inverter, ensure the minimum insulation resistance to ground of the PV string meets the minimum insulation resistance requirement ($R = \text{Max. Input Voltage (V)} / 30\text{mA}$).
- Do not connect the same PV string to multiple inverters, as this may damage the inverters.
- The PV modules used with the inverter must comply with IEC 61730 Class A standards.
- When the PV string input voltage or input current is high, it may cause the inverter output power to derate.

1.3.2 Inverter Safety

WARNING

- Ensure the voltage and frequency at the grid connection point comply with the inverter's grid-connection specifications.
- It is recommended to install protective devices such as circuit breakers or fuses on the AC side of the inverter. The rating of the protective device must be greater than 1.25 times the maximum AC output current of the inverter.
- If the inverter triggers an arc fault alarm less than 5 times within 24 hours, the alarm can be cleared automatically. After the 5th arc fault alarm, the inverter will shut down for protection. The inverter can resume normal operation only after the fault is cleared.
- If a battery is not configured in the photovoltaic system, it is not recommended to use the BACK-UP function, as it may cause a system power outage risk.
- Grid voltage and frequency fluctuations may cause the inverter output power to derate.

1.3.3 Battery Safety

DANGER

- Before operating any devices in the system, ensure that the devices are powered off to avoid the risk of electric shock. During device operation, strictly adhere to all safety precautions in this manual and the safety labels on the devices.
- Do not disassemble, modify, or repair the battery without official authorization from the device manufacturer. Otherwise, it may cause electric shock or device damage, and any losses incurred are beyond the manufacturer's liability.
- Do not impact, pull, drag, squeeze, or step on the device, and do not place the battery in fire, as the battery may explode.
- Do not place the battery in high-temperature environments. Ensure there are no heat sources near the battery and that it is not exposed to direct sunlight. If the ambient temperature exceeds 60°C, it may cause a fire.
- Do not use the battery if it has obvious defects, cracks, damage, or other conditions. Battery damage may lead to electrolyte leakage.
- Do not move the battery system while it is operating. If battery replacement or addition is needed, contact the after-sales service center.
- Battery short circuits may cause personal injury. The instantaneous high current from a short circuit can release a large amount of energy, which may lead to a fire.
- To protect the battery pack and its components from damage during transportation, ensure that transport personnel are professionally trained. Record the operating steps during transportation and keep the device balanced to avoid dropping.
- The battery device is heavy. Assign personnel according to the device's weight to prevent it from exceeding the weight range that can be manually handled, which could cause injury to personnel.



- Battery current may be affected by factors such as temperature, Humidity, weather conditions, etc., which may cause current limiting and affect load capacity.
- If the battery cannot start, contact the after-sales service center as soon as possible. Otherwise, the battery may be permanently damaged.
- Regularly inspect and maintain the battery according to its maintenance requirements.
- Ensure that the battery system is not damaged during transportation and storage. Ensure that the device is placed stably and not tilted, as tipping may cause device damage and personal injury.

Emergency Response Measures

- Battery electrolyte leakage
If a battery module leaks electrolyte, avoid contact with the leaking liquid or gas. Electrolyte is corrosive and contact may cause skin irritation and chemical burns. If accidental contact with the leaked substance occurs, take the following actions:
 - inhalation: Evacuate from the contaminated area and seek medical help immediately.
 - Eye contact: Rinse with clean water for at least 15 minutes and seek medical help immediately.
 - Skin contact: Wash the affected area thoroughly with soap and water and seek medical help immediately.
 - Ingestion: Induce vomiting and seek medical assistance immediately.
- Fire
 - When the battery temperature exceeds 150°C, there is a risk of fire. A battery fire may release toxic and harmful gases.
 - To prevent fire, ensure carbon dioxide or water fire extinguishing equipment is available near the device.
 - When extinguishing a fire, do not use ABC dry powder fire extinguishers. Firefighters must wear protective clothing and self-contained breathing apparatus.
- Battery triggers fire protection
For batteries equipped with optional fire protection functionality, after the fire protection function is triggered, perform the following actions:
 - Immediately cut off the main power switch to ensure no current flows through the battery system.

- Conduct a preliminary visual inspection of the battery for any damage, deformation, leakage, or unusual odor. Check the battery casing, connectors, and cables.
- Use a temperature sensor to detect the battery and its ambient temperature to ensure there is no risk of overheating.
- Isolate and label the damaged battery, and dispose of it properly according to local regulations.

1.3.4 Smart Meter Safety



WARNING











If the grid voltage fluctuation exceeds 265V, long-term overvoltage operation may cause damage to the meter. It is recommended to add a fuse with a rated current of 0.5A on the voltage input side of the meter to protect it.





1.4 Safety Symbols and Certification Marks

DANGER

- After equipment installation, labels and warning signs on the enclosure must remain clearly visible. Do not cover, alter, or damage them.
- The following enclosure warning label descriptions are for reference only. Please refer to the actual labels used on the equipment.

No.	Symbol	Meaning
1		Potential hazard exists during equipment operation. Please take protective measures when operating the equipment.
2		High voltage hazard. High voltage is present during equipment operation. Please ensure the equipment is powered off before performing any operations.

No.	Symbol	Meaning
3		The inverter surface is at high temperature. Do not touch during operation to avoid burns.
4		Use the equipment properly. There is a risk of explosion under extreme conditions.
5		Battery contains flammable materials. Beware of fire.
6		The equipment contains corrosive electrolyte. Avoid contact with leaked electrolyte or volatile gases.
7		Delayed discharge. After powering off the equipment, please wait 5 minutes for it to discharge completely.
8		Keep the equipment away from open flames or ignition sources.
9		Keep the equipment out of reach of children.
10		Do not extinguish with water.
11		Please read the product manual carefully before operating the equipment.
12		Personal protective equipment must be worn during installation, operation, and maintenance.
13		This equipment must not be disposed of as household waste. Please dispose of it according to local laws and regulations, or return it to the manufacturer.

No.	Symbol	Meaning
14		Grounding point.
15		Recycling symbol.
16		CE certification mark.
17		TUV mark.
18		RCM mark.

1.5 EU Declaration of Conformity

1.5.1 Equipment with Wireless Communication Modules

Equipment with wireless communication modules sold in the European market must comply with the following directives:

- Radio Equipment Directive 2014/53/EU (RED)
- Restrictions of Hazardous Substances Directive 2011/65/EU and (EU) 2015/863 (RoHS)
- Waste Electrical and Electronic Equipment 2012/19/EU
- Registration, Evaluation, Authorization and Restriction of Chemicals (EC) No 1907/2006 (REACH)

1.5.2 Equipment without Wireless Communication Modules (Except Battery)

Equipment without wireless communication modules that can be sold in the European market meets the requirements of the following directives:

- Electromagnetic compatibility Directive 2014/30/EU (EMC)

- Electrical Apparatus Low Voltage Directive 2014/35/EU (LVD)
- Restrictions of Hazardous Substances Directive 2011/65/EU and (EU) 2015/863 (RoHS)
- Waste Electrical and Electronic Equipment 2012/19/EU
- Registration, Evaluation, Authorization and Restriction of Chemicals (EC) No 1907/2006 (REACH)

1.5.3 Battery

Batteries sold in the European market must comply with the following directives:

- Electromagnetic compatibility Directive 2014/30/EU (EMC)
- Electrical Apparatus Low Voltage Directive 2014/35/EU (LVD)
- Battery Directive 2006/66/EC and Amending Directive 2013/56/EU
- Waste Electrical and Electronic Equipment 2012/19/EU
- Registration, Evaluation, Authorization and Restriction of Chemicals (EC) No 1907/2006 (REACH)

For more EU Declarations of Conformity, please visit the [official website](#).

2 System Introduction

2.1 System Overview

The All-in-One Home Energy Storage Solution integrates devices such as inverters, batteries, Smart Meters, and smart communication sticks. In a photovoltaic system, it converts solar energy into electricity to meet household power demands. The energy IoT devices in the system manage electrical appliances by identifying the overall power situation, thereby achieving intelligent management of electricity for supplying loads, storing to batteries, or exporting to the grid.

WARNING

- The energy storage system is not suitable for connecting devices that rely on stable power supply, such as life-sustaining medical equipment, etc. Please ensure that when the system is powered off, it does not cause personal injury..
- If the all-in-one home storage unit is in a high-temperature or BMS current-limiting condition, it may cause the battery charging power to be limited, leading to system overvoltage triggering overvoltage protection.
- In microgrid scenarios, it is recommended that the PV open-circuit voltage of the all-in-one home storage unit be $< 0.85 \times PV$ maximum input voltage to avoid system overvoltage triggering overvoltage protection under harsh operating conditions.
- In microgrid scenarios, please ensure that the over-frequency power reduction point of the grid-tied inverter is consistent with that of the all-in-one home storage unit.
- If the grid-tied inverter needs to limit output power, please connect a meter or CT device separately.
- Please ensure that the over-frequency power reduction curve of the grid-tied inverter is set as follows:
 - Set the end power to $0\%P_n$
 - Set the response delay time to 0, and disable the hysteresis function
- In a system where the inverter operates completely off-grid, if the battery is in low light or rainy weather for a long time and cannot be replenished in time, it may lead to over-discharge, causing battery performance degradation or damage. To ensure long-term stable operation of the system, avoid completely

!WARNING

draining the battery. Recommended measures are as follows:

- When operating off-grid, set the minimum SOC protection threshold. It is recommended to set the off-grid battery SOC lower limit to 30%.
- When the SOC approaches the protection threshold, the system will automatically enter power limitation or protection mode.
- If there is insufficient light for several consecutive days and the battery SOC is too low, promptly replenish the battery with external energy sources (such as a generator or grid-assisted charging).
- Regularly check the battery status to ensure it is within the safe operating range.
- It is recommended to fully charge and discharge the battery every six months to calibrate SOC accuracy.
- Due to product version upgrades or other reasons, the document content will be updated periodically. For the compatibility relationship between inverters and IoT products, please refer to:
https://en.goodwe.com/Ftp/EN/Downloads/User%20Manual/GW_Compatibility-list-of-GoodWe-inverters-and-IoT-products-EN.pdf
- For detailed networking and wiring schemes for each scenario, please refer to:
[5.2.Detailed System Wiring Diagram\(Page 83\)](#).

When the energy storage system is in off-grid mode, it can normally supply the following loads:

BACK-UP Port Off-Grid Load Capacity Specification				
Inverter Model	GW5K-ETA-G20 GW6K-ETA-G20 GW8K-ETA-G20 GW9.999K-ETA-G20 GW10K-ETA-G20 GW12K-ETA-G20 GW15K-ETA-G20 GW20K-ETA-G20		GW25K-ETA-G20 GW29.999K-ETA-G20 GW30K-ETA-G20	
Load Type	Single-phase	Three-phase	Single-phase	Three-phase

BACK-UP Port Off-Grid Load Capacity Specification				
Single Motor Load Rated Power (kVA)	1.1	3.3	2.2	6.6
Total Rated Power of Multiple Motor Loads (kVA)	$0.4 \cdot P_n / 3$	$0.4 \cdot P_n$	$0.4 \cdot P_n / 3$	$0.4 \cdot P_n$
Capacitive Load (kVA)	$0.33 \cdot P_n / 3$	$0.33 \cdot P_n$	$0.33 \cdot P_n / 3$	$0.33 \cdot P_n$
Half-wave Load (kW)	2	-	3	-
<p>Note:</p> <ul style="list-style-type: none"> • P_n: Inverter rated output power. • Half-wave Load: Some old or non-EMC compliant household appliances (such as hair dryers, small heaters using half-wave rectification). • If the total power of multiple motor loads calculated based on rated power is less than the rated power of a single motor load, then the total rated power of multiple motor loads equals the rated power of a single motor load. 				

General Scenario

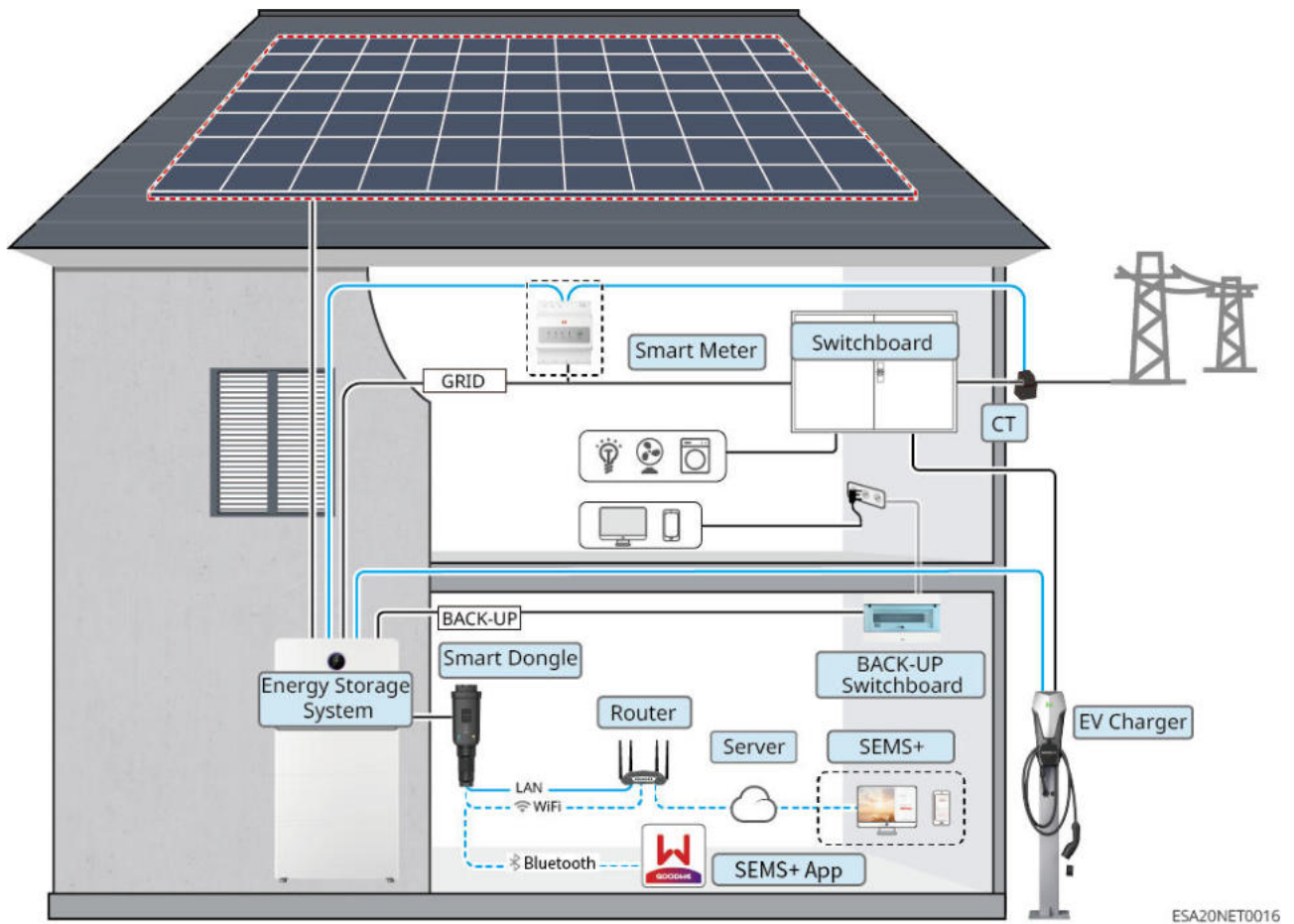

Device Type	model	Description
hybrid inverter	GW5K-ETA-G20	<ul style="list-style-type: none"> • Can be connected to a GOODWE rgingpile. • Supports generator control and generator charging of the battery. If a generator connection is required, please use the GMK330 or GM330 Smart Meter.
	GW6K-ETA-G20	
	GW8K-ETA-G20	
	GW9.999K-ETA-G20	
	GW10K-ETA-G20	
	GW12K1-ETA-G20	
	GW15K-ETA-G20	
	GW20K-ETA-G20	
	GW25K-ETA-G20	
	GW29.999K-ETA-G20	
GW30K-ETA-G20		

Device Type	model	Description
Battery system	GW5.1-BAT-D-G20 GW5.1-BAT-D-G21 GW8.3-BAT-D-G20 GW8.3-BAT-D-G21	<ul style="list-style-type: none"> • Different models of battery modules support mixed use. • The system supports 5-96kWh, meeting different power and energy matching requirements. • When mixing GW5.1-BAT-D-G20, GW8.3-BAT-D-G20 with GW5.1-BAT-D-G21, GW8.3-BAT-D-G21, the operating environment temperature requirement shall be based on GW5.1-BAT-D-G21, GW8.3-BAT-D-G21. • If the system has requirements for split-type expansion, please ensure the BMS and DCDC software versions are V04 or above.
Smart Meter	Inverter built-in meter	<ul style="list-style-type: none"> • Built-in meter: Please use the CT shipped with the box to connect to the inverter. <ul style="list-style-type: none"> ◦ CT ratio is 120A:40mA. ◦ When the inverter's built-in meter does not meet the usage requirements, you can contact dealers or others to purchase a GMK330 or GM330 Smart Meter. • GMK330: CT cannot be replaced, CT ratio is 120A:40mA • GM330: CT can be purchased from GOODWE or independently, CT ratio is nA: 5A.
	GMK330 (purchased from GOODWE)	
	GM330 (purchased from GOODWE)	

Device Type	model	Description
Smart dongle	WiFi/LAN Kit-20	<ul style="list-style-type: none"> • Uses Bluetooth signals for local configuration of device parameters and viewing device operation information, and uses WiFi or LAN to upload system operation information to the monitoring platform. • Please ensure the Smart Dongle's firmware version is 06 or above.

Microgrid Scenario

When a grid-tied inverter is connected to the hybrid inverter's BACK-UP port, it constitutes a Microgrid Scenario.

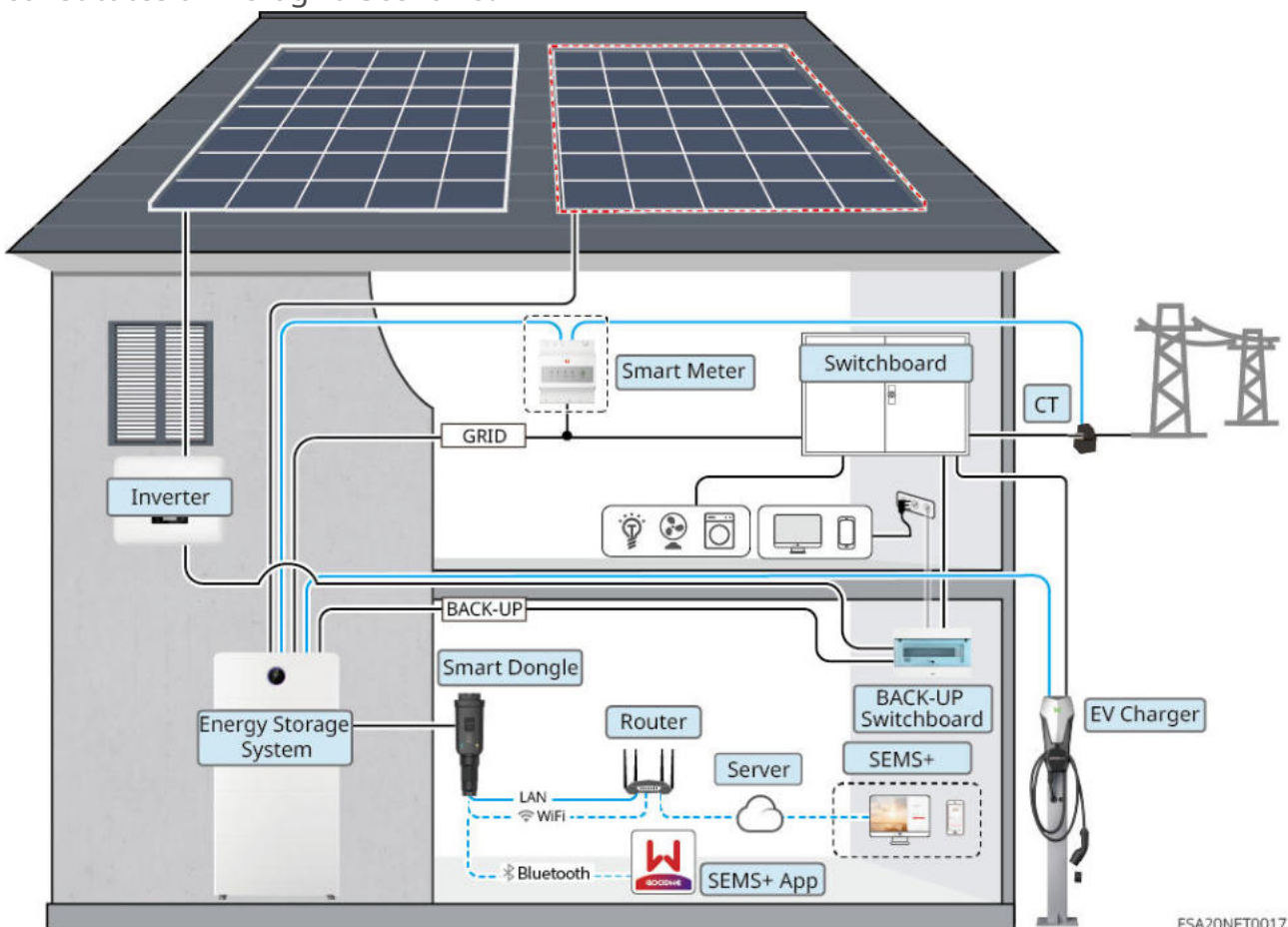

ESA20NET0017

Device Type	model	Description
hybrid inverter	GW5K-ETA-G20 GW6K-ETA-G20 GW8K-ETA-G20 GW9.999K-ETA-G20 GW10K-ETA-G20 GW12K-ETA-G20 GW15K-ETA-G20 GW20K-ETA-G20 GW25K-ETA-G20 GW29.999K-ETA-G20 GW30K-ETA-G20	<ul style="list-style-type: none"> • In a microgrid scenario, only one hybrid inverter is supported in the system. • In a microgrid scenario, connecting a generator is not supported.
Battery system	GW5.1-BAT-D-G20 GW5.1-BAT-D-G21 GW8.3-BAT-D-G20 GW8.3-BAT-D-G21	<ul style="list-style-type: none"> • Battery modules of different models can be mixed. • The system supports 5-96kWh, meeting different power and energy matching requirements. • When GW5.1-BAT-D-G20, GW8.3-BAT-D-G20 are mixed with GW5.1-BAT-D-G21, GW8.3-BAT-D-G21, the operating ambient temperature requirement shall follow that of GW5.1-BAT-D-G21 and GW8.3-BAT-D-G21. • If the system requires split-type expansion, ensure the BMS and DCDC software version is V04 or higher.
Smart Meter	Inverter Built-in Meter GMK330 (Purchase from GoodWe)	

Device Type	model	Description
	GM330 (Purchase from GoodWe)	<ul style="list-style-type: none"> • Built-in meter: Use the CT shipped with the inverter to connect to the inverter. <ul style="list-style-type: none"> ◦ CT ratio is 120A:40mA ◦ If the inverter's built-in meter does not meet the requirements, contact your dealer to purchase a GMK330 or GM330 Smart Meter. • GMK330: CT cannot be replaced; CT ratio is 120A:40mA • GM330: CT can be purchased from GoodWe or elsewhere; CT ratio is nA:5A
Smart dongle	WiFi/LAN Kit-20	<ul style="list-style-type: none"> • Uses Bluetooth signals for local configuration of device parameters and viewing device operation information. Uses WiFi or LAN to upload system operation information to the monitoring platform. • Ensure the firmware version of the Smart dongle is 06 or higher.

Device Type	model	Description
grid-tied PV inverter	-	<ul style="list-style-type: none"> • It is recommended to use GoodWe brand grid-tied PV inverters; third-party grid-tied PV inverters are also supported. • In a microgrid scenario, ensure the rated output power of the grid-tied PV inverter \leq the rated output power of the hybrid inverter. • When the microgrid system is in grid-connected mode, if power limitation is required, ensure: <ul style="list-style-type: none"> ◦ For the hybrid inverter, set it in the Grid Power Limitation interface of the ShineCloud+ App. For the grid-tied PV inverter, set it according to the actual tool used. ◦ To ensure the grid-tied PV inverter can continue generating power, adjust the output power of the hybrid inverter in the Microgrid Mode interface of the ShineCloud+ App. <p>Note: The output power control precision varies among different grid-tied PV inverters. Set the grid power limitation parameter value according to the actual situation.</p>

Coupled Scenario

When a grid-tied inverter is connected to the hybrid inverter's GRID port, it constitutes a Coupled Scenario.

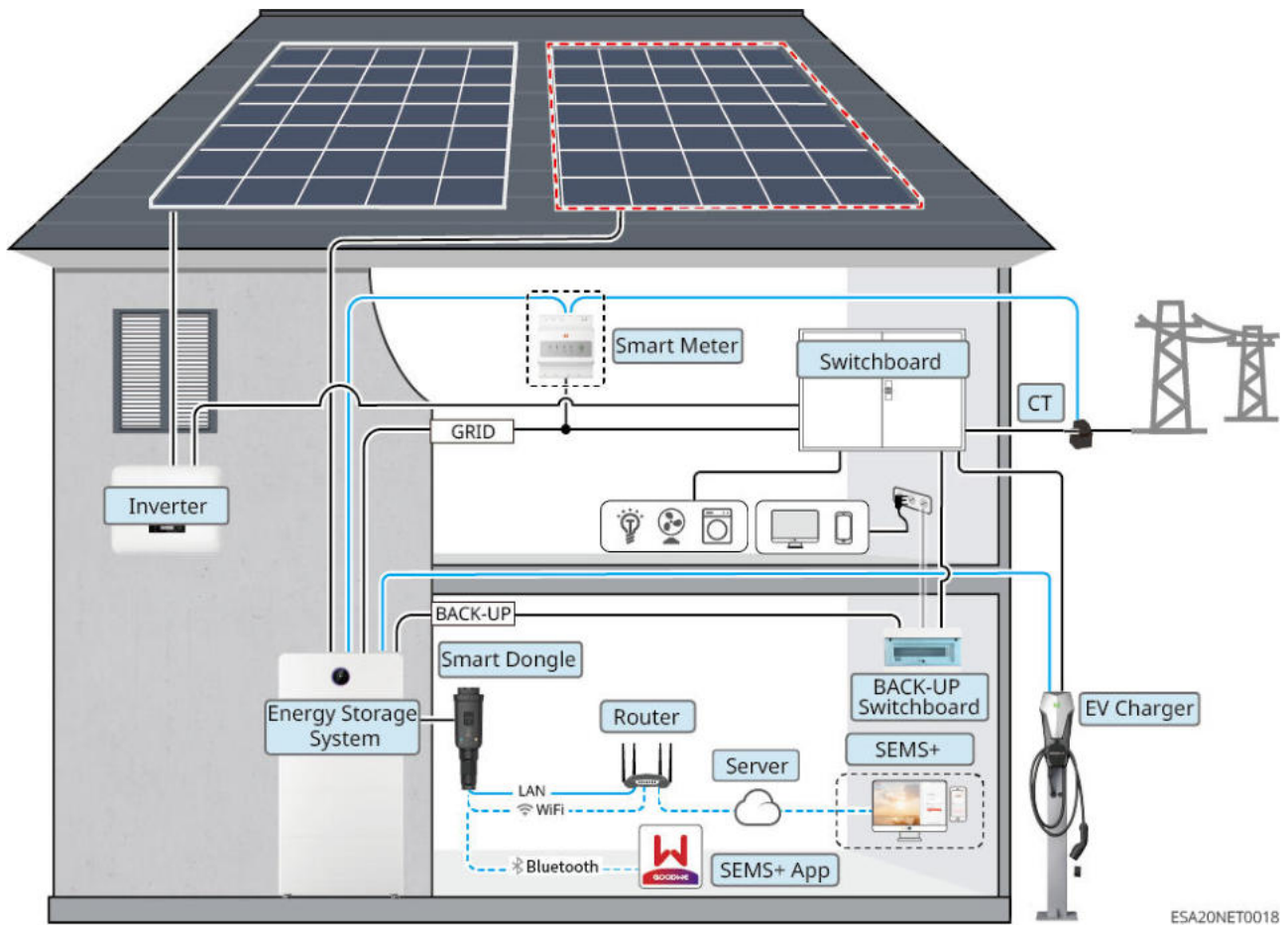

Device Type	model	Description
hybrid inverter	GW5K-ETA-G20	<ul style="list-style-type: none"> • Can be connected to GoodWe AC charging pile. • Supports generator control and generator charging the battery.If you need to connect a generator, please use GMK330 or GM330 Smart Meter.
	GW6K-ETA-G20	
	GW8K-ETA-G20	
	GW9.999K-ETA-G20	
	GW10K-ETA-G20	
	GW12K-ETA-G20	
	GW15K-ETA-G20	
	GW20K-ETA-G20	
	GW25K-ETA-G20	
	GW29.999K-ETA-G20	
	GW30K-ETA-G20	

Device Type	model	Description
Battery system	GW5.1-BAT-D-G20 GW5.1-BAT-D-G21 GW8.3-BAT-D-G20 GW8.3-BAT-D-G21	<ul style="list-style-type: none"> • Battery modules of different models can be mixed. • The system supports 5-96kWh, meeting different power and energy matching requirements. • GW5.1-BAT-D-G20, GW8.3-BAT-D-G20 and GW5.1-BAT-D-G21, GW8.3-BAT-D-G21 can be mixed. When mixing, the operating environment temperature requirements should follow GW5.1-BAT-D-G21 and GW8.3-BAT-D-G21. • If the system requires split expansion, ensure that the BMS and DCDC software versions are V04 or above.
Smart Meter	Inverter built-in meter	<ul style="list-style-type: none"> • Built-in meter: Please use the CT shipped with the box to connect to the inverter. <ul style="list-style-type: none"> ◦ CT ratio is 120A:40mA ◦ If the built-in meter of the inverter does not meet the requirements, you can contact dealers to purchase GMK330 or GM330 Smart Meter. • GMK330: CT cannot be replaced, CT ratio is 120A:40mA. • GM330: CT can be purchased from GoodWe or independently, CT ratio is nA:5A.
	GMK330 (purchased from GoodWe)	
	GM330 (purchased from GoodWe)	

Device Type	model	Description
Smart dongle	WiFi/LAN Kit-20	<ul style="list-style-type: none"> • Uses Bluetooth signals for local configuration of device parameters and viewing device operation information, and uploads system operation information to the monitoring platform via WiFi or LAN. • Ensure that the firmware version of the Smart dongle is 06 or above.
grid-tied PV inverter	-	<ul style="list-style-type: none"> • It is recommended to use GoodWe brand grid-tied PV inverters, and third-party grid-tied PV inverters are supported. • In coupling scenarios, ensure that the rated output power of the grid-tied PV inverter is \leq the rated output power of the hybrid inverter. • When the coupling system is in grid-connected state, if power limitation is required, ensure: the hybrid inverter should be set through the SEMS+ App grid-connected power limitation interface, and the grid-tied PV inverter should be set according to the actual tools used. <p>Note: The output power control accuracy of different grid-tied PV inverters varies, please set the grid-connected power limitation parameter values according to the actual situation.</p>

2.2 Product Overview

2.2.1 Residential Three-Phase All-in-One

Residential Three-Phase All-in-One:

The Residential Three-Phase All-in-One uses a blind plug stacking connection method and integrates the Inverter and Battery units through modular design.

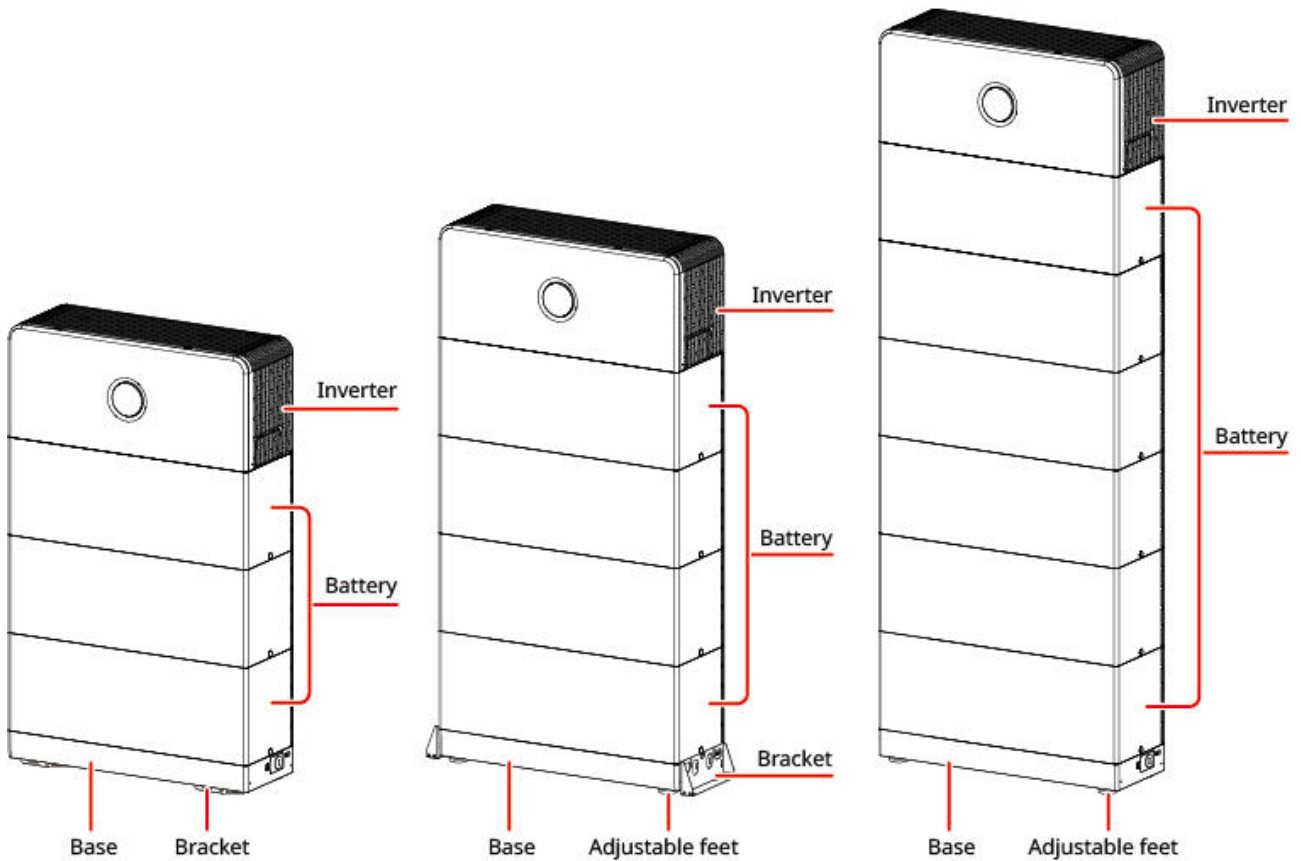

ESA20DSC0007

The energy storage system supports Battery capacity expansion. The total Battery capacity is determined by the number and specifications of Battery modules. Configuration must strictly adhere to the restrictions specified in this section. Overall system configuration description:

Mounting Method	Total Number of Batteries	Expansion Group Count	Stacking per Group
Floor Installation	≤12 units	≤3 groups	Away from wall ≤4 units Against wall ≤6 units
Wall-mounted Installation (5kWh model)	≤9 units	≤3 groups	≤3 units
Wall-mounted Installation (8kWh/5kWh+8kWh model)	≤6 units	≤3 groups	≤2 units

Mounting Method	Total Number of Batteries	Expansion Group Count	Stacking per Group
Note: Expansion Group Count × Stacking per Group ≤ Total System Battery Count			

Wall-mounted Installation

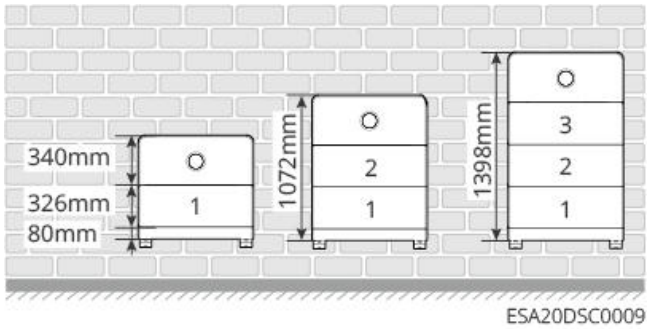

Floor-standing Installation

- Against-wall installation

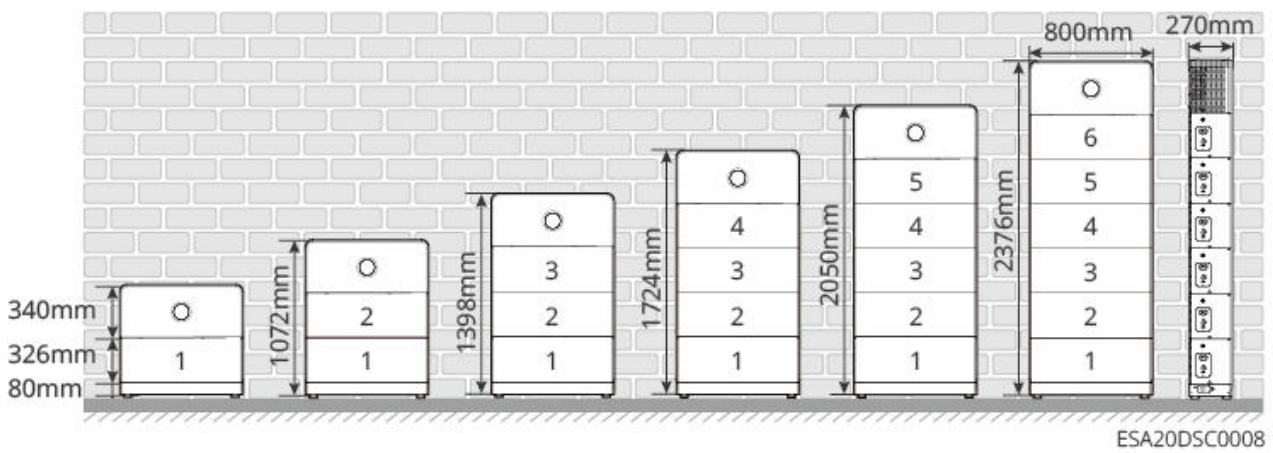

- Away-from-wall installation

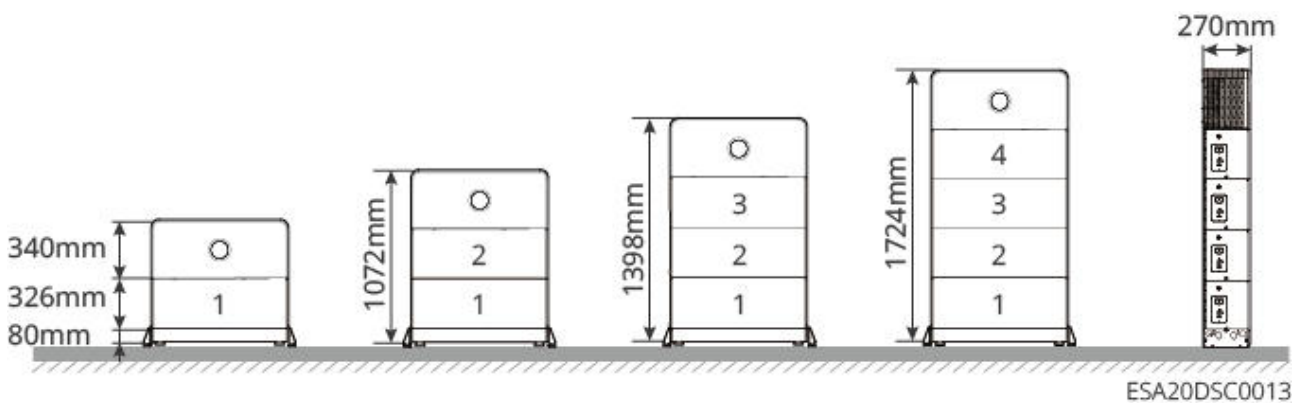

Cluster Expansion Installation

- Floor-standing installation

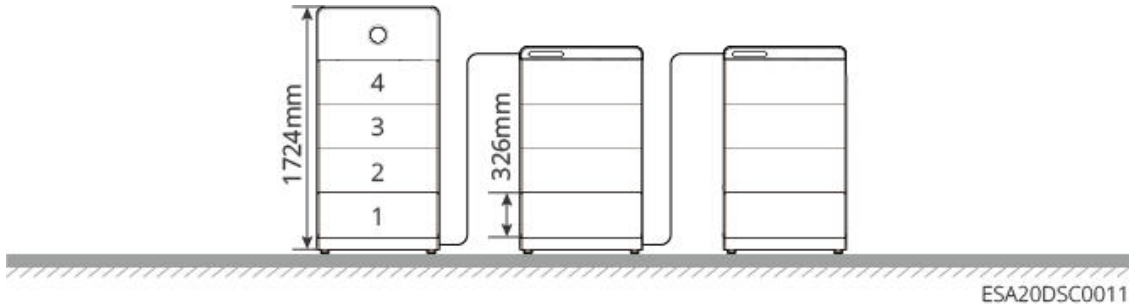

- Wall-mounted installation

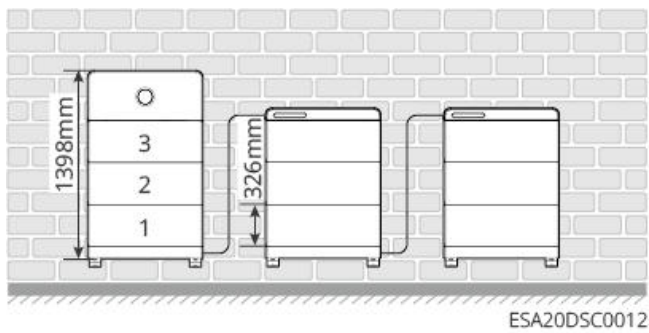

Inverter:

The Inverter controls and optimizes the energy flow in the photovoltaic system through an integrated energy management system. It can supply the electricity generated in the photovoltaic system to loads, store it in the Battery, or output it to the grid, etc.

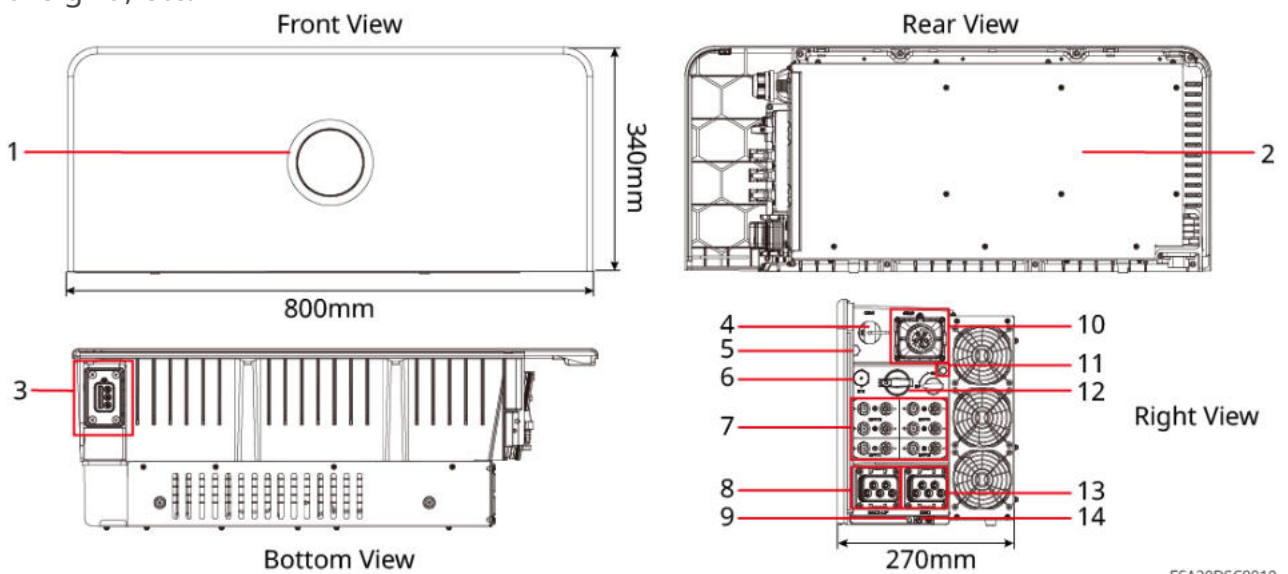

ESA20DSC0010

No.	Component/Silkscreen	Description
1	indicator	Indicates the operating status of the inverter.
2	heat sink	Dissipates heat for the inverter.
3	Connector	Power and Communication Port for connecting the inverter to the battery.
4	Smart Communication Stick Connection Port	<ul style="list-style-type: none"> • Can connect to smart communication sticks, such as WiFi/LAN communication modules. Please select the module type according to actual needs. • Supports connecting a USB flash drive for local inverter software version upgrade.
5	Ventilation valve	-
6	STS Communication Interface	Reserved
7	PV Input Terminals	<ul style="list-style-type: none"> • Can connect to DC input cables from PV modules. • The number of PV input terminals is as follows: <ul style="list-style-type: none"> ◦ GW5K-ETA-G20, GW6K-ETA-G20, GW8K-ETA-G20, GW6K-EHA-G20: 3 ◦ GW9.999K-ETA-G20, GW10K-ETA-G20, GW12K-ETA-G20, GW15K-ETA-G20, GW20K-ETA-G20, GW25K-ETA-G20, GW29.999K-ETA-G20, GW30K-ETA-G20: 4
8	BACK-UP Port	Connects to AC cables, connecting to critical loads or grid-tied inverters.
9	Battery Mounting Holes	Secures the inverter and the battery.

No.	Component/Silkscreen	Description
10	Communication Port	Can connect communication cables for load control, CT, RS485, Remote Shutdown/Rapid Shutdown, DRED (Australia)/RCR (Europe), etc.
11	Lifting Handle Mounting Holes	Used for installing the lifting handle. Used when moving the inverter.
12	DC Switch	Controls the connection or disconnection of the DC input.
13	GRID Port	Connects to AC cables, connecting the inverter to the grid.
14	Grounding terminal	Connects the chassis protective ground wire.

Battery:

The Battery system can store and release electricity according to the requirements of the photovoltaic energy storage system. The input and output ports of this energy storage system are high-voltage direct current.

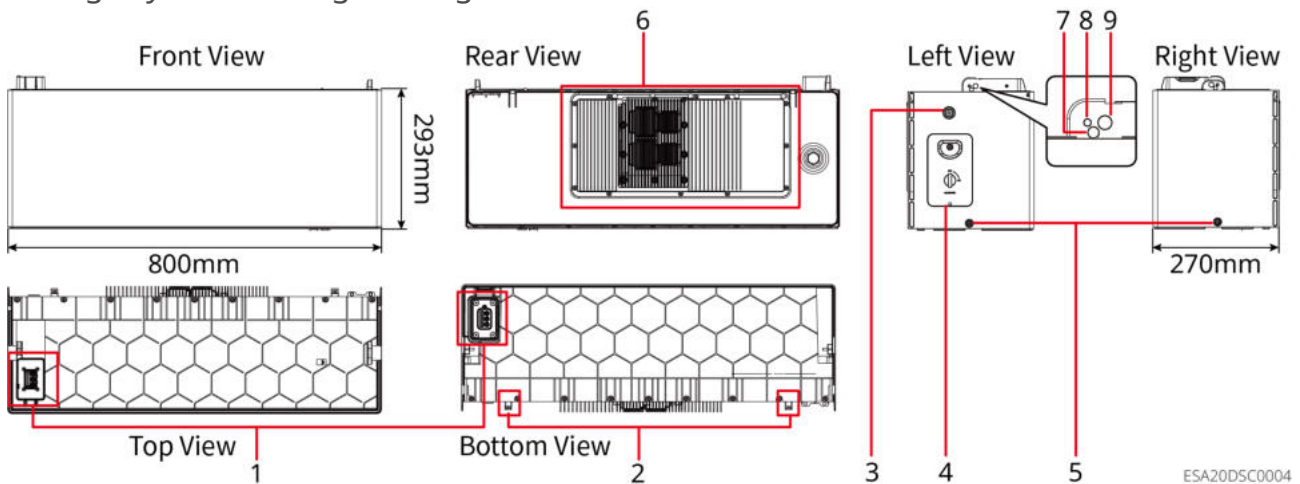

No.	Part	Description
1	Connector	Power and Communication Port for connections between batteries, and between battery and inverter.

No.	Part	Description
2	Anti-tip bracket mounting hole	Used for fixing the battery to the wall.
3	Multi-function button indicator light	<ul style="list-style-type: none"> Indicates the battery operating status. Battery black start function: When there is no PV power generation in the photovoltaic system and the grid is abnormal, the inverter cannot work normally; you can press and hold the multi-function button for 2 seconds to start the battery system, activate the inverter, so that the inverter enters off-grid mode operation, and the battery discharges to power the load. Battery power-off function: Press and hold the multi-function button for >5 seconds to power off the battery system.
4	Battery isolation switch	Battery power input and output switch.
5	Battery inter-fixing hole	For fixing between two batteries.
6	heat sink	Battery heat dissipation
7	Battery hoisting hole	Used for hoisting the battery. When stacking more than three batteries, use hoisting tools for installation.
8	Battery or inverter fixing hole	Used for fixing between batteries or between inverter and battery.
9	Lifting rod mounting hole	Used for installing the lifting rod. Used during manual handling of the battery.

2.2.2 Smart Meter

The Smart Meter measures and monitors electrical data in the photovoltaic energy

storage system, such as: voltage, current, frequency, Power Factor, power, etc.

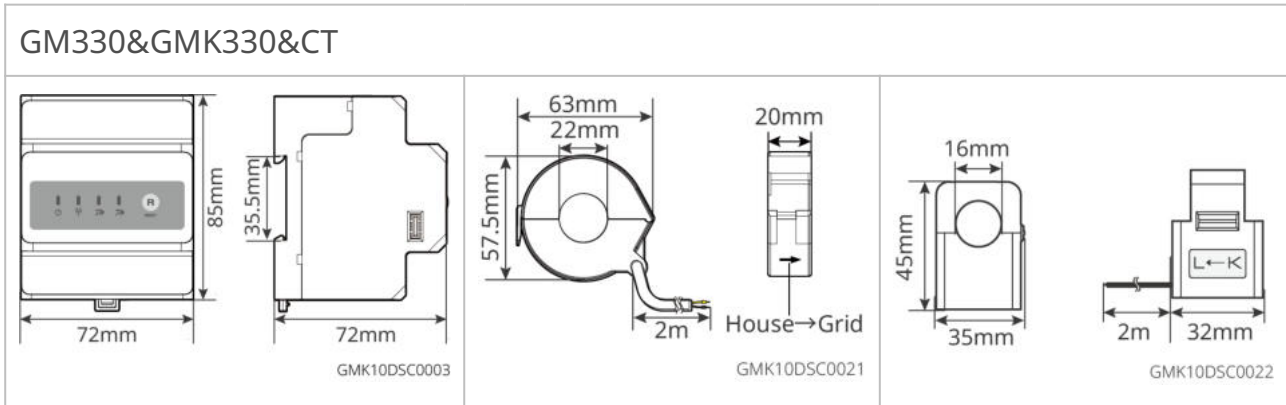

No.	model	Applicable Scenarios
1	GM330	<p>CT can be purchased from GoodWe or separately. CT ratio requirement: nA: 5A</p> <ul style="list-style-type: none"> nA: CT primary side input current, n range is 200-5000 5A: CT secondary side output current
2	GMK330	<p>CT is shipped with the meter. CT ratio:</p> <ul style="list-style-type: none"> 120A: 40mA

2.2.3 smart dongle

The smart dongle is mainly used for real-time transmission of various power generation data from inverters to remote monitoring platforms, and for connecting the smart dongle via the SEMS+ App for proximal device debugging.

WiFi/LAN Kit-20

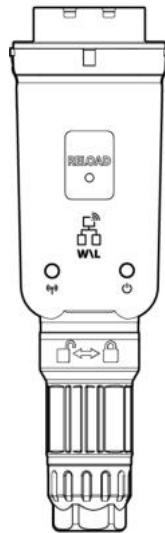

Smart dongle 0006

No.	model	Signal Type	Applicable Scenario
1	WiFi/LAN Kit-20	WiFi, LAN, Bluetooth	Can upload system operation information to the monitoring platform via WiFi or LAN signals

2.3 Supported Grid Types

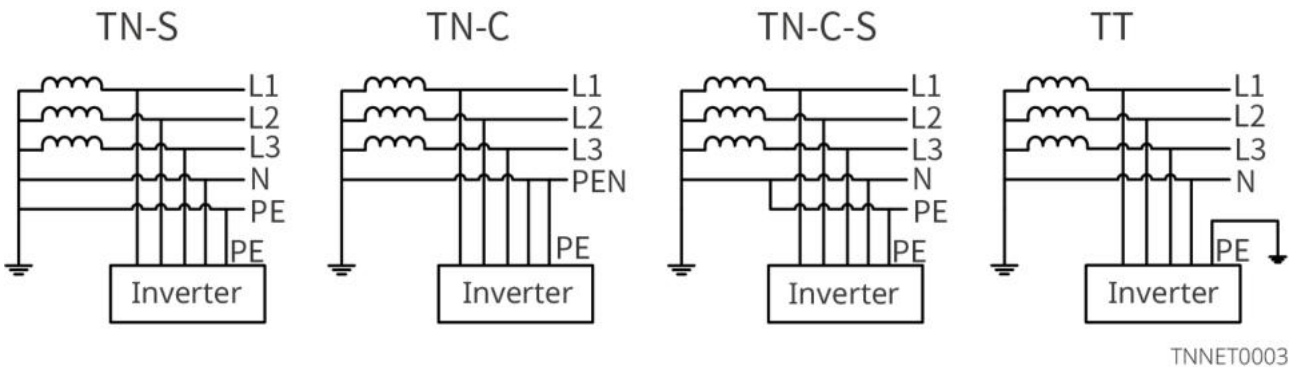

2.4 System Working Mode

Self-consumption

- The basic operating mode of the system.
- PV generation first supplies power to the loads, excess energy charges the battery, and any remaining energy is sold to the grid. When PV generation cannot meet the

load demand, the battery supplies power to the loads; when the battery power is also insufficient to meet the load demand, the grid supplies power to the loads.

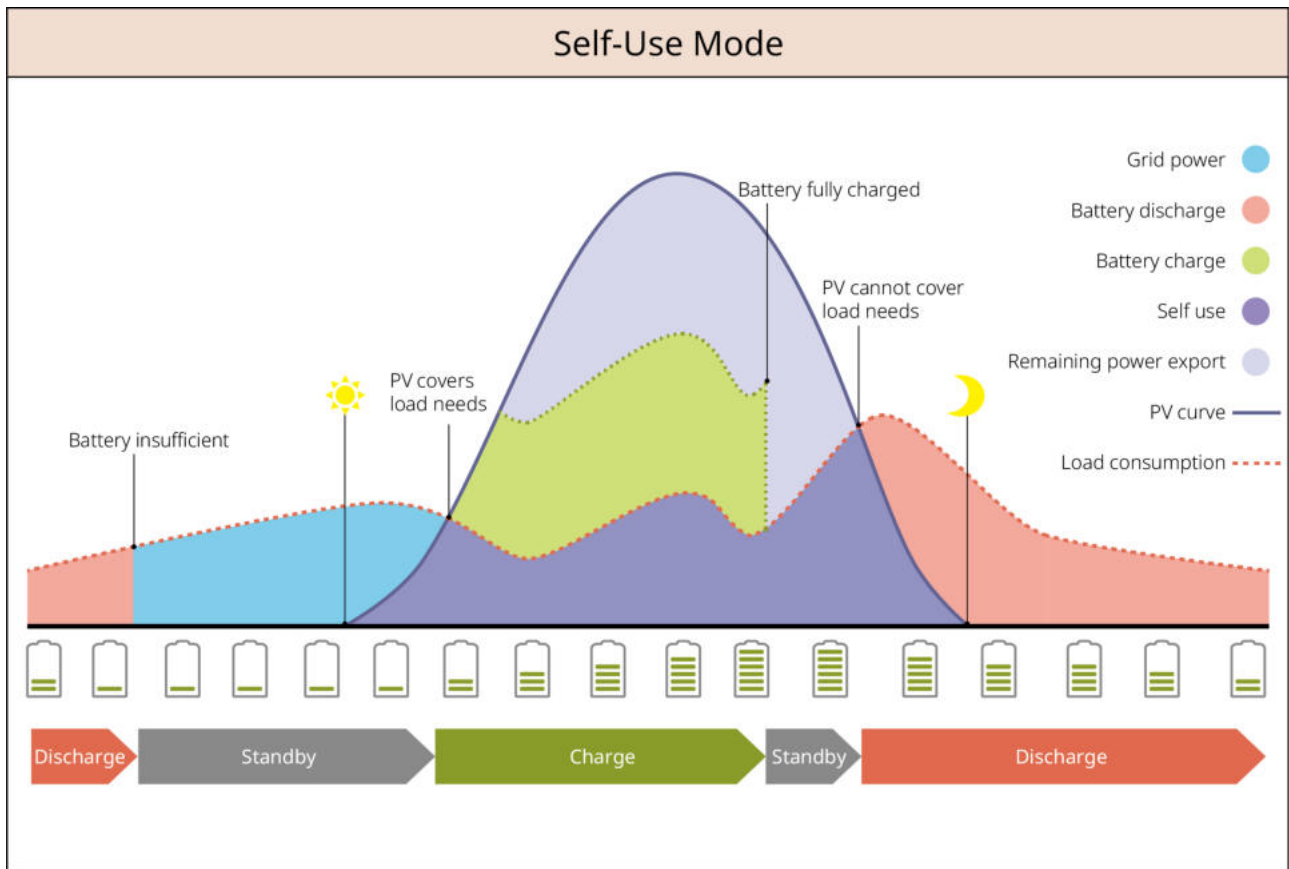

SLG00NET0009

Backup Mode

- Recommended for use in areas with unstable grids.
- When the grid fails, the inverter switches to off-grid working mode, and the battery discharges to supply power to the loads, ensuring uninterrupted power for the BACK-UP Loads. When the grid is restored, the inverter switches its working mode back to grid-connected operation.
- To ensure the battery SOC is sufficient to maintain normal system operation during off-grid periods, the system will charge the battery using PV or by purchasing electricity from the grid to the backup power SOC during grid-connected operation. If purchasing electricity from the grid to charge the battery, please ensure compliance with local grid laws and regulations.

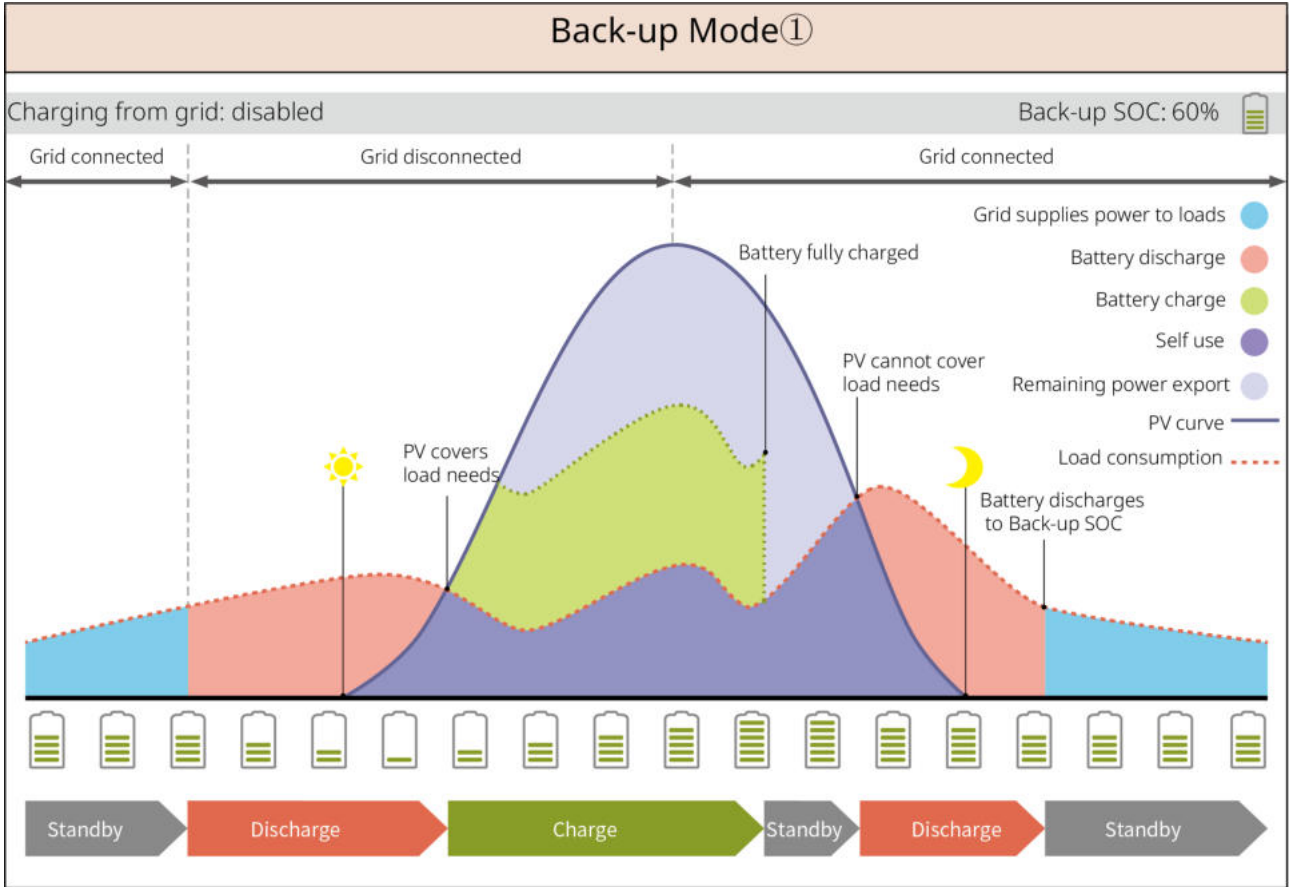

SLG00NET0002

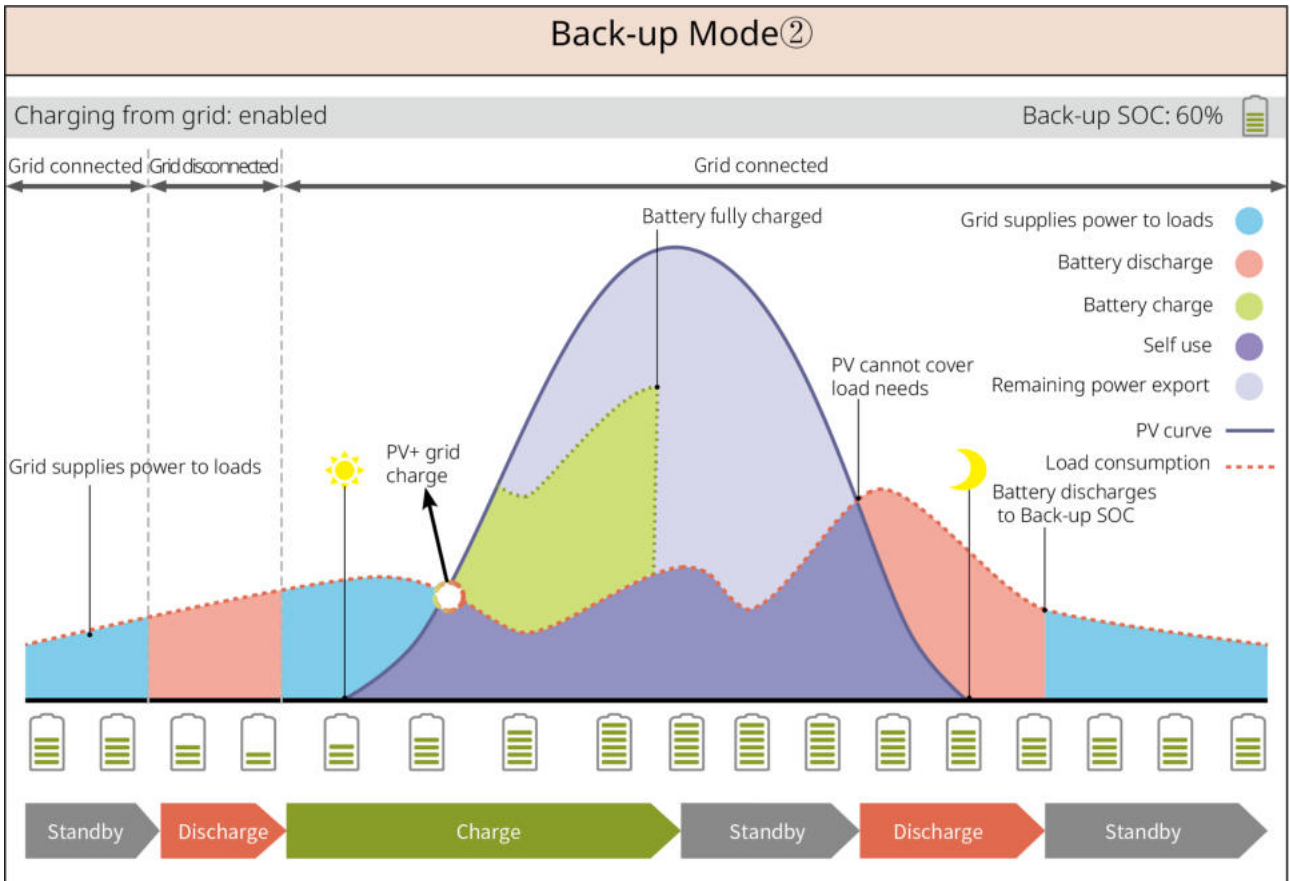

SLG00NET0003

TOU Mode

In compliance with local laws and regulations, buy and sell electricity during different time periods based on the difference between peak and valley grid electricity prices. For example: During valley price periods, set the battery to charging mode to purchase electricity from the grid for charging; during peak price periods, set the battery to discharging mode to supply power to the loads via the battery.

TOU Mode①

PV: Charge battery in priority

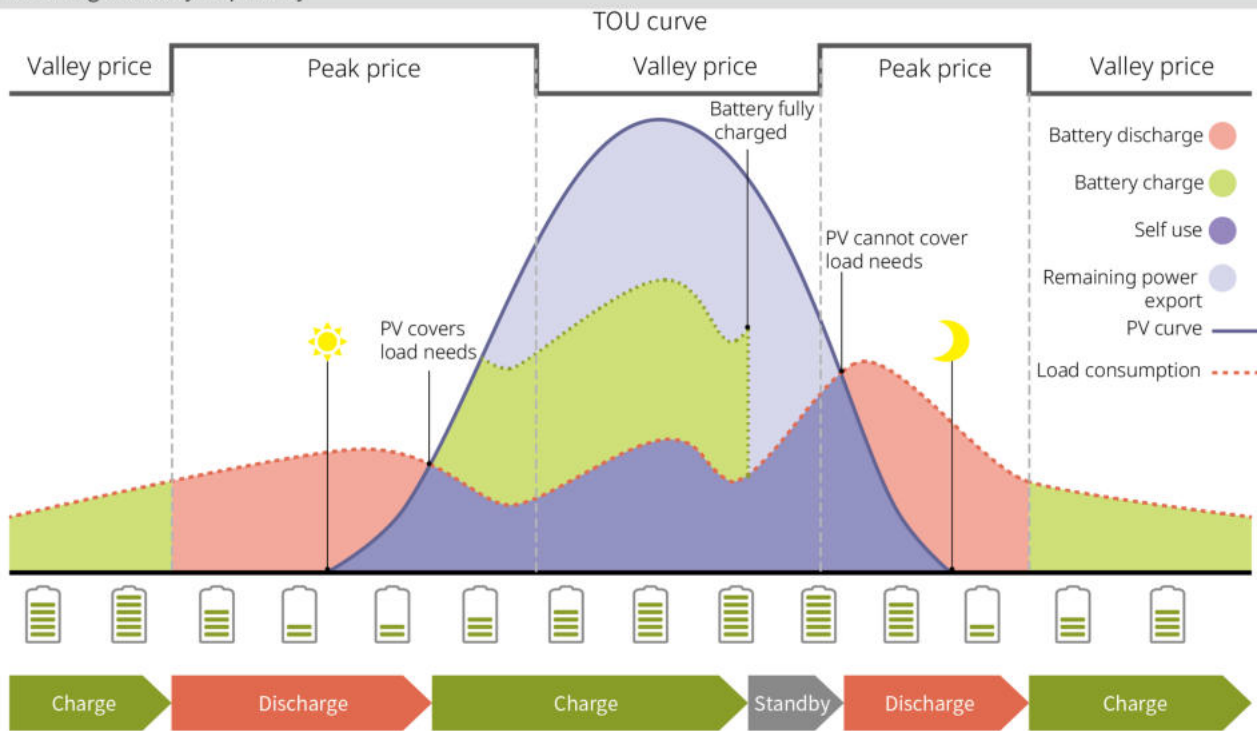

SLG00NET0004

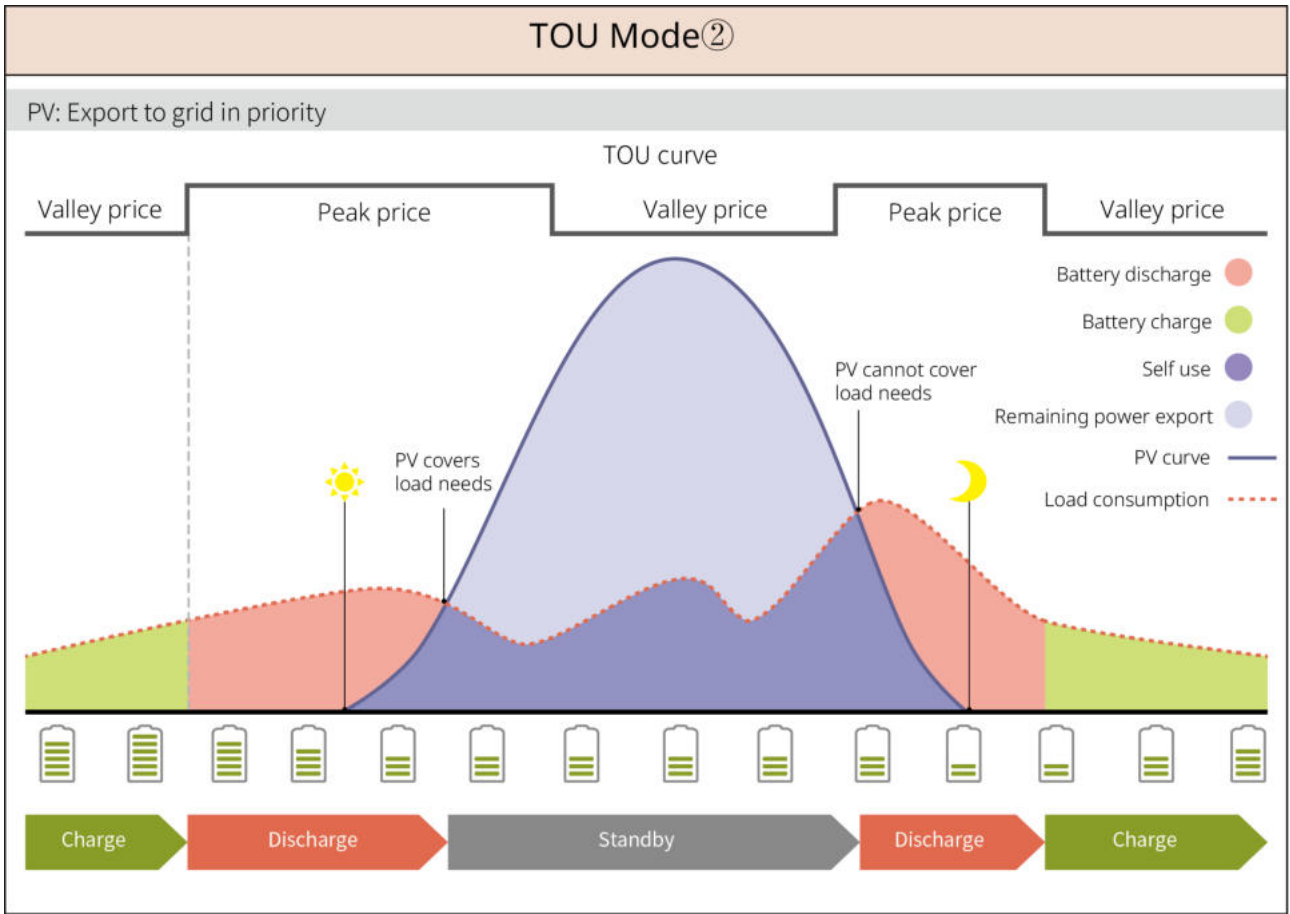

SLG00NET0005

Delayed Charging Mode

- Suitable for areas with grid-connected power output limits.
- Setting a peak power limit can use PV generation exceeding the grid connection limit to charge the battery; or setting a PV charging period to utilize PV generation for charging the battery during that period.

Smart Charging ①

PV > Peak Limit

Switch to Charge: enabled/disabled

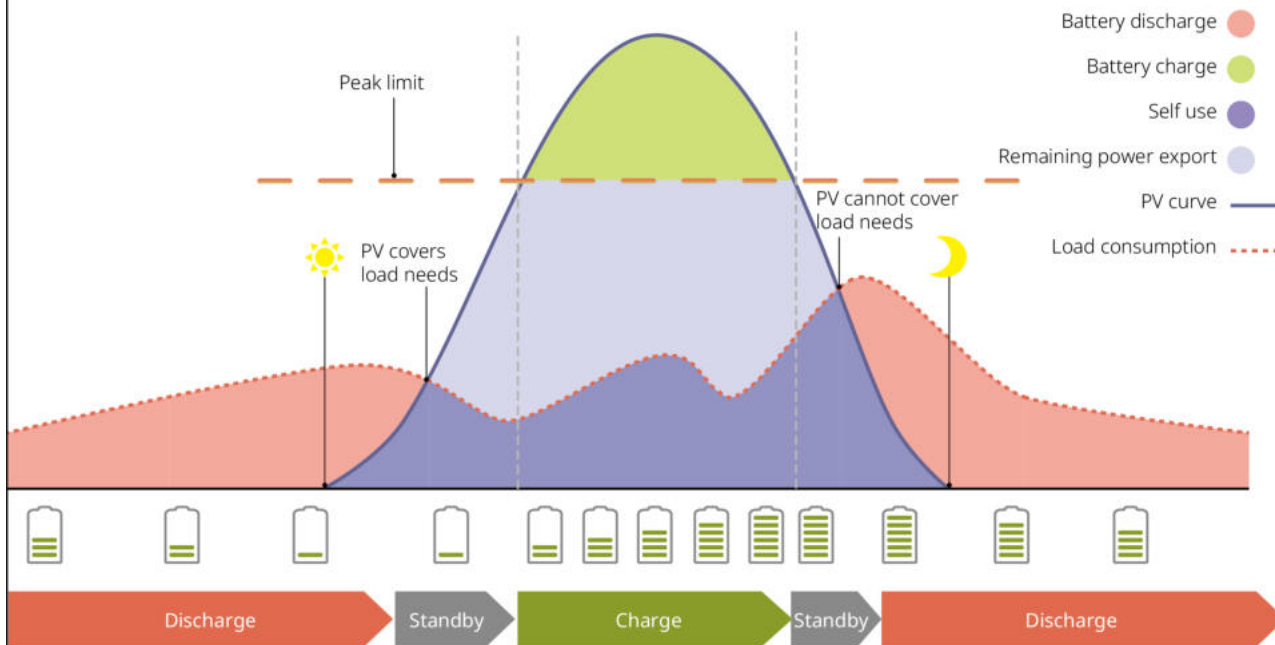

SLG00NET0006

Smart Charging ②

PV < Peak Limit

Switch to Charge: enabled

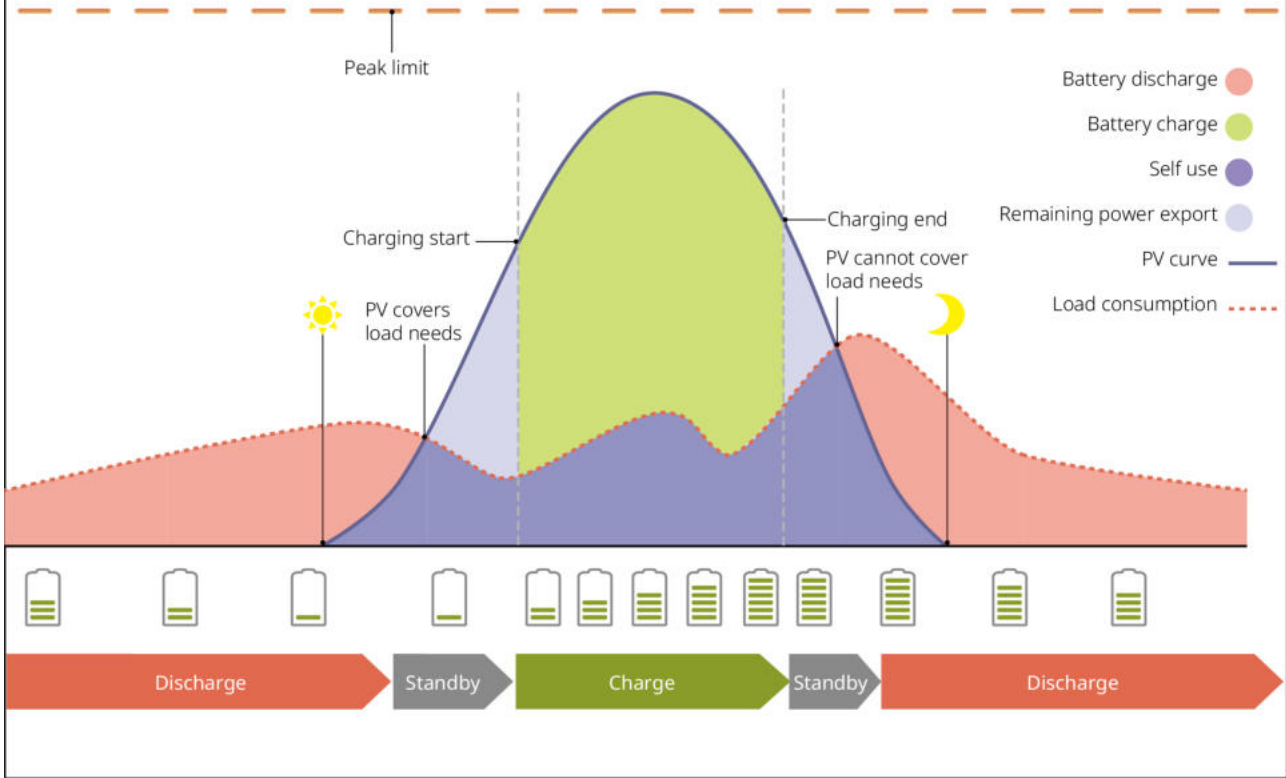

SLG00NET0007

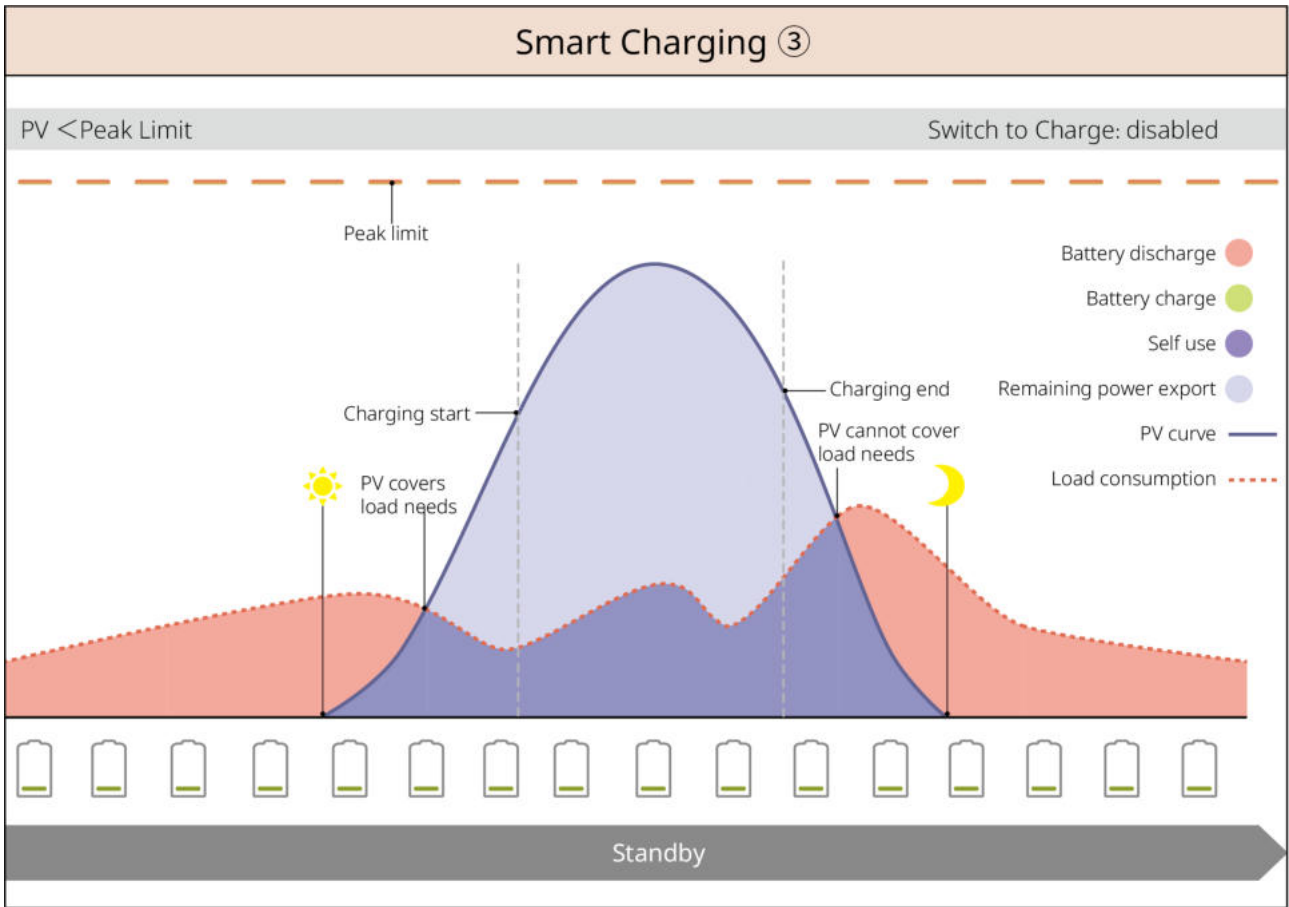

Demand Control Mode

- Primarily applicable to commercial and industrial scenarios.
- When the total load power consumption exceeds the electricity quota within a short period, battery discharge can be used to reduce the portion of consumption exceeding the quota.
- When the battery SOC is lower than the reserved SOC for demand control, the system purchases electricity from the grid based on the time period, load consumption, and peak purchase power limit.

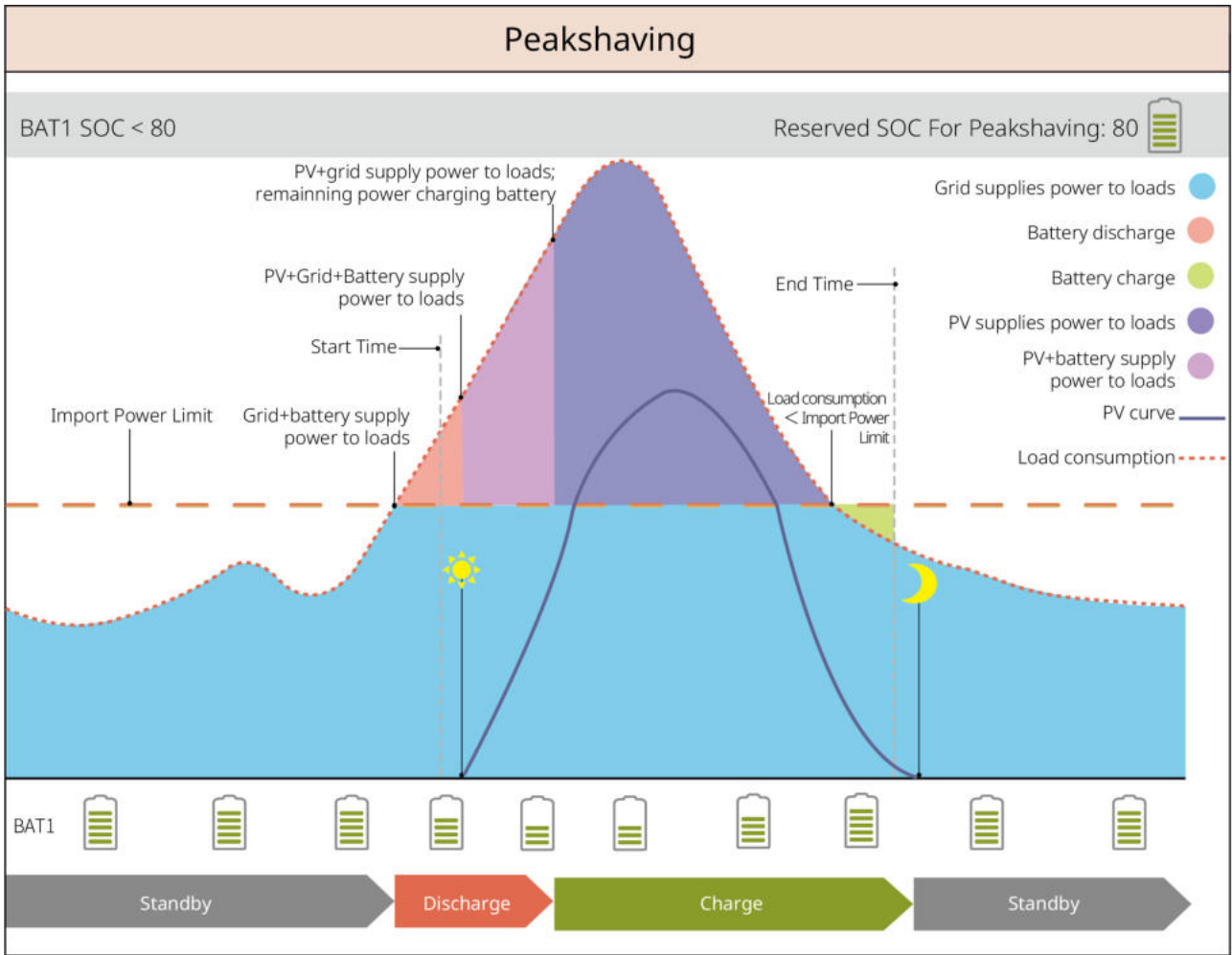

SLG00NET0001

Off-grid Mode

NOTICE

When the inverter is not connected to the battery system, do not operate in pure off-grid mode.

When the grid fails, the inverter switches to off-grid working mode.

- During the day, PV generation first supplies power to the loads, and excess energy charges the battery.
- At night, the battery discharges to supply power to the loads, ensuring uninterrupted power for the BACK-UP Loads.

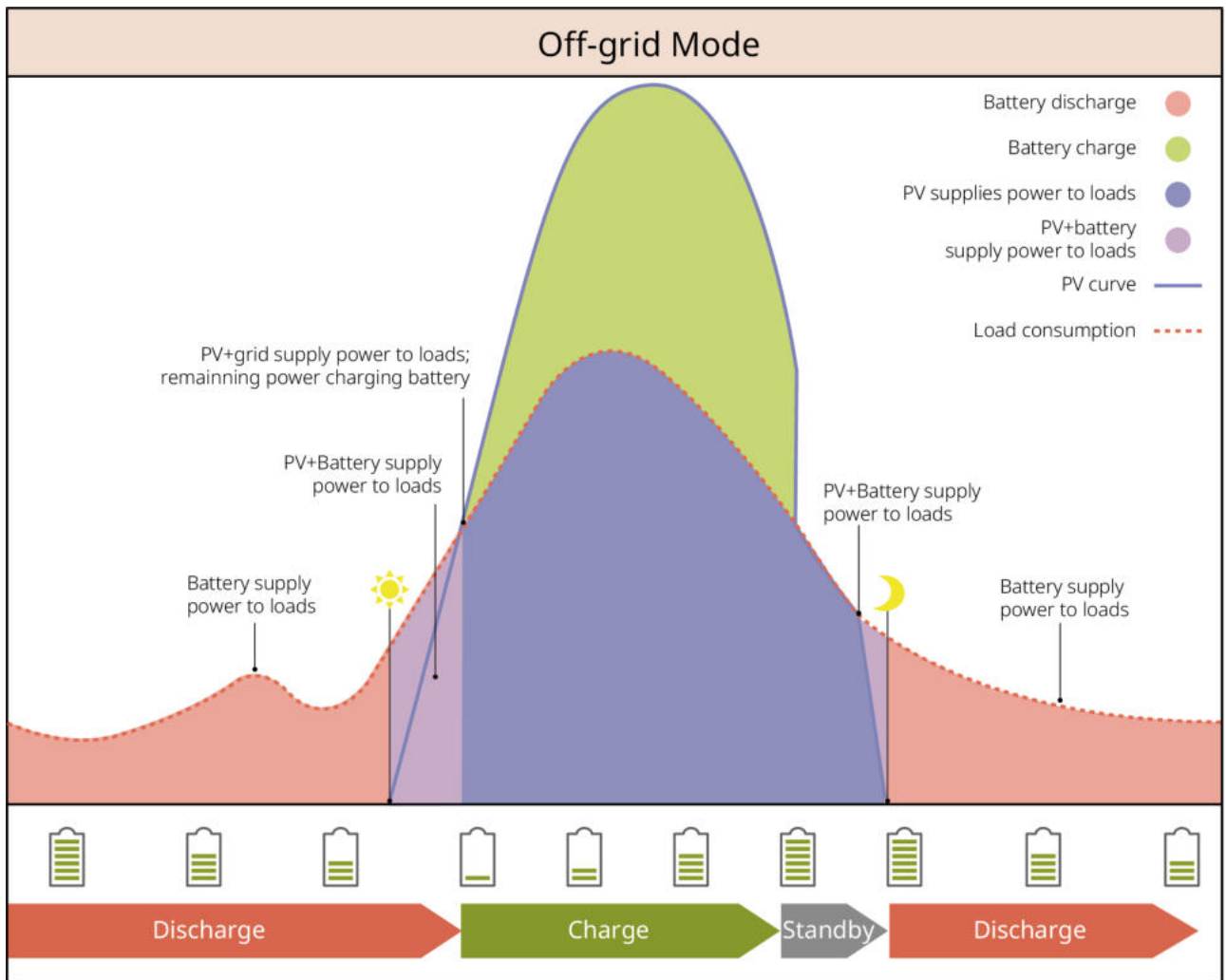

SLG00NET0012

2.5 Features

NOTICE

Specific features are subject to the actual product configuration.

AFCI

The inverter integrates an AFCI circuit protection device, used to detect arc faults and quickly cut off the circuit when detected, thereby preventing electrical fires.

Causes of arc generation:

- Damage to connector connections in the photovoltaic system.
- Incorrect or damaged cable connections.
- Aging of connectors and cables.

Fault handling methods:

1. When the inverter detects an arc occurrence, the fault type can be viewed through the App.
2. If the inverter triggers a fault less than 5 times within 24 hours, after waiting for 5 minutes, the machine will automatically restore grid connection protection. After the 5th arc fault, the fault must be cleared before the inverter can operate normally. For specific operations, please refer to the 'SEMS+ App User Manual'.

model	Label	Description
GW5K-ETA-G20 GW6K-ETA-G20 GW8K-ETA-G20	AFCI: F-I-AFPE-1-2/1-2	<p>F (Full coverage) : Full coverage of inverter PV input ports</p> <p>I (Integrated) : Integrated within the inverter</p> <p>AFPE (arc fault protection equipment) : Combines both AFD and AFI arc detection functions</p> <p>1: One pair of PV input ports (PV+, PV-) connects to one PV input string</p> <p>2/1: One arc detection channel has 2 MPPT inputs; one arc detection channel has 1 MPPT input;</p> <p>2: There are 2 arc detection channels</p>
GW9.999K-ETA-G20 GW10K-ETA-G20 GW12K-ETA-G20 GW15K-ETA-G20 GW20K-ETA-G20	AFCI: F-I-AFPE-1-2/2-2	<p>F (Full coverage) : Full coverage of inverter PV input ports</p> <p>I (Integrated) : Integrated within the inverter</p> <p>AFPE (arc fault protection equipment) : Combines both AFD and AFI arc detection functions</p> <p>1: One pair of PV input ports (PV+, PV-) connects to one PV input string</p> <p>2/2: Each arc detection channel has 2 MPPT inputs;</p> <p>2: There are 2 arc detection channels</p>

model	Label	Description
GW25K-ETA-G20 GW29.999K-ETA-G20 GW30K-ETA-G20	AFCI: F-I-AFPE-1-2/4-2	<p>F (Full coverage) : Full coverage of inverter PV input ports</p> <p>I (Integrated) : Integrated within the inverter</p> <p>AFPE (arc fault protection equipment) : Combines both AFD and AFI arc detection functions</p> <p>1: One pair of PV input ports (PV+, PV-) connects to one PV input string</p> <p>2/4: One arc detection channel has 2 MPPT inputs; one arc detection channel has 4 MPPT inputs;</p> <p>2: There are 2 arc detection channels</p>

Three-phase unbalanced output

Both the grid connection end and the BACK-UP end of the inverter support three-phase unbalanced output, and each phase can be connected to loads of different power. The maximum output power per phase for different models is shown in the table below:

No.	model	Single-Phase Maximum Output Power
1	GW5K-ETA-G20	2.5kW
2	GW6K-ETA-G20	3kW
3	GW8K-ETA-G20	4kW
4	GW9.999K-ETA-G20	5kW
5	GW10K-ETA-G20	5kW
6	GW12K-ETA-G20	6kW
7	GW15K-ETA-G20	7.3kW
8	GW20K-ETA-G20	7.3kW
9	GW25K-ETA-G20	11kW

No.	model	Single-Phase Maximum Output Power
10	GW29.999K-ETA-G20	11kW
11	GW30K-ETA-G20	11kW

Rapid Shutdown (RSD) Rapid Shutdown

In the Rapid Shutdown system, the Rapid Shutdown transmitter and receiver are used together to achieve rapid system shutdown. The receiver maintains component output by receiving signals from the transmitter. The transmitter can be external or built into the inverter. In case of an emergency, by enabling the external trigger device, the transmitter can be stopped, thereby shutting down the components.

- External transmitter
 - Transmitter models: GTP-F2L-20, GTP-F2M-20
<https://en.goodwe.com/Ftp/Installation-instructions/RSD2.0-transmitter.pdf>
 - Receiver models: GR-B1F-20, GR-B2F-20
https://en.goodwe.com/Ftp/EN/Downloads/User%20Manual/GW_RSD-20_Quick-Installation-Guide-POLY.pdf
- Built-in transmitter
 - External trigger device: external switch
 - Receiver models: GR-B1F-20, GR-B2F-20
https://en.goodwe.com/Ftp/EN/Downloads/User%20Manual/GW_RSD-20_Quick-Installation-Guide-POLY.pdf

3 Check and Storage

3.1 Check Before Receiving

Before receiving the product, please carefully check the following:



1. Check if the outer packaging is damaged, such as deformation, holes, cracks, or other signs that could cause damage to the equipment inside the box. If damaged, do not open the packaging and contact your dealer.
2. Check if the device model is correct. If it does not match, do not open the packaging and contact your dealer.





3.2 deliverables

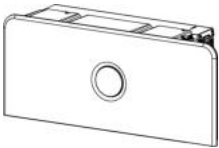
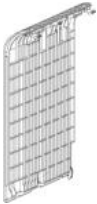

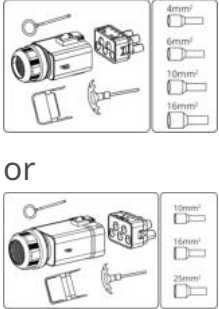
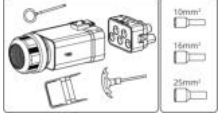
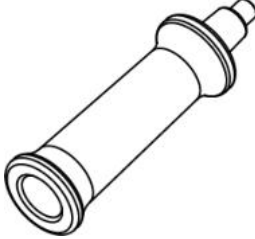

 **WARNING**

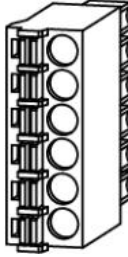
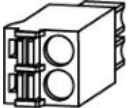

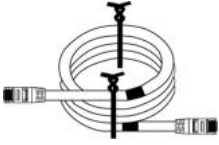
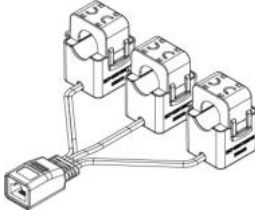
Check if the type and quantity of the delivered items are correct, and if there is any damage to the appearance. If there is any damage, please contact your dealer. After removing the delivered items from the packaging, do not place them on rough, uneven, or sharp surfaces to avoid paint chipping.

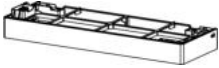
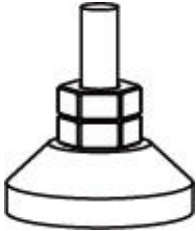
3.2.1 Inverter Deliverables

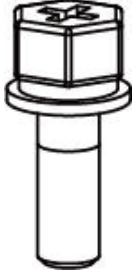
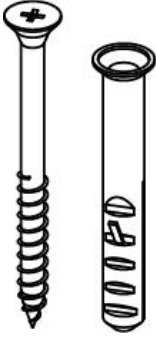
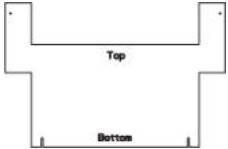
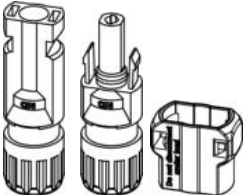

Component	Description	Component	Description
	Inverter x 1		Decorative cover top x 1
	Decorative cover left x 1		Decorative cover right x 1

Component	Description	Component	Description
 <p>or</p> 	<p>AC terminal kit x 2</p> <ul style="list-style-type: none"> AC wiring terminal x 2 PIN terminal x N <ul style="list-style-type: none"> 5-20kW: <ul style="list-style-type: none"> 4mm² x 5 6mm² x 5 10mm² x 5 16mm² x 5 25-30kW: <ul style="list-style-type: none"> 10mm² x 5 16mm² x 5 25mm² x 5 		<p>Handle x 2</p>
	<p>OT grounding terminal x 1</p>		<p>6PIN communication terminal x 2</p>
	<p>2PIN communication terminal x 2</p>		<p>PIN terminal x 16</p>
	<p>CT connection cable x 1</p>		<p>CT x 1</p>

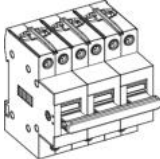

Component	Description	Component	Description
	Battery base x 1		Adjustable feet x 4
	Anti-tip bracket x 4		M5*16 screw x 9
	M5*60 expansion screw x 4		Drilling template paper x 2
			PV terminal unlocking tool x N N: China region x 0; Other regions x 1.

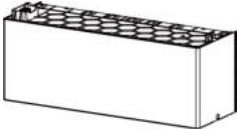
Component	Description	Component	Description
	PV terminal and PV terminal anti-tamper cover <ul style="list-style-type: none"> GW5K-ETA-G20 , GW6K-ETA-G20 , GW8K-ETA-G20, GW6K-EHA-G20: 3 GW9.999K-ETA-G20, GW10K-ETA-G20, GW12K-ETA-G20, GW15K-ETA-G20, GW20K-ETA-G20, GW25K-ETA-G20, GW29.999K-ETA-G20, GW30K-ETA-G20: 4 		Smart dongle x 1
	Product documentation x 1		Manual transfer switch (Australia only) x 1

3.2.2 Batteries Deliverables

Part	Description	Part	Description
	Battery x 1		M5*16 screw x 2
	Silicone cap x 2	-	-

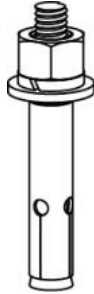

Bracket Installation (Optional)









Part	Description	Part	Description
	Bracket x 2		M10 expansion bolt x 6
	M10 screw x 4	-	-

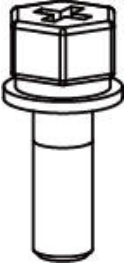
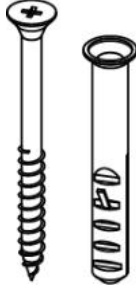
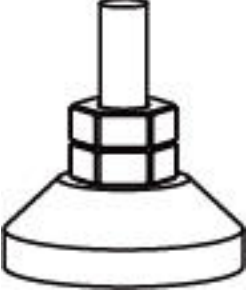

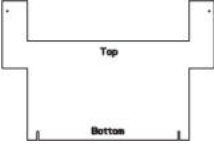

3.2.2.1 Battery Expansion Kit Deliverables

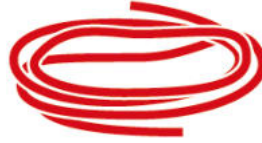
NOTICE

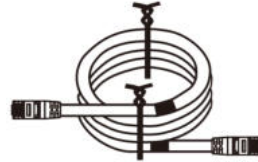

The system supports 5-96kWh. A single column can stack up to 6 batteries, with a maximum energy of 48kWh. For scenarios requiring more energy, needing to reduce the single-column stacking height due to installation constraints, or other expansion needs, please contact GoodWe or distributors to purchase a battery expansion kit.

Part	Description	Part	Description
	Base x 1		locking bracket x 4

Part	Description	Part	Description
	M5 Screw x 7		M6 Expansion Screw x 4
	Adjustable Feet x 4		OT Grounding Terminal x 1
	Terminal resistor x 1		Battery Decorative Cover x 1
	Drilling Marking Paper x 2		Battery Expansion Cluster Harness x 1
	PIN terminal x 8		Battery Expansion Cluster Positive Connection Harness x 1
	Battery Expansion Cluster Negative Connection Harness x 1		Battery Expansion Cluster Network Cable x 1



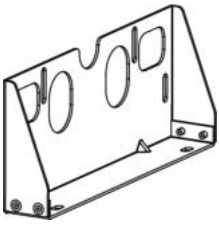

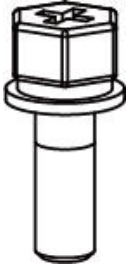

Part	Description	Part	Description
	Silicone Cap x 2		Handle x 2
	Hex Key x 1		Product Documentation x 1

3.2.2.2 Wall-Mount Bracket Delivery Kit

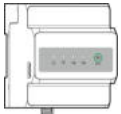
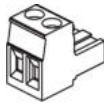
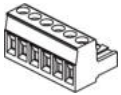
Part	Description	Part	Description
	Wall-mount bracket x 2		M6 expansion bolt x 4
	M5 fixing screw x 4	-	-

3.2.3 Smart Meter Delivery Set GM330&GMK330

3.2.3.1 Attachment List

Component	Description	Component	Description
	Smart meter x1		2PIN communication terminal x1
	6PIN communication terminal x1		7PIN communication terminal x1
	Meter communication terminal		screwdriver x1
	PIN terminal x 6		Product documentation x 1

3.3 Storage

- If the inverter has been stored for more than two years or has not been in operation for more than six months after installation, it is recommended to have it inspected and tested by professionals before putting it into use.
- To ensure the good electrical performance of the internal electronic components of the inverter, it is recommended to power it on every six months during storage; if it has not been powered on for more than six months, it is recommended to have it inspected and tested by professionals before putting it into use.
- To protect battery performance and service life, it is recommended to avoid long-term idle storage. Prolonged storage may cause deep discharge of the battery, leading to irreversible chemical damage, resulting in capacity 衰减 or even complete failure, it is advised to use it promptly. If the battery needs to be stored for a long time, please maintain it according to the following requirements:

NOTICE

[1] The storage time is calculated from the SN date on the battery's outer packaging. After exceeding the storage period, charge and discharge maintenance is required. (Battery maintenance time = SN date + charge/discharge maintenance cycle). For how to view the SN date, refer to: [10.4.Battery SN Code Meaning\(Page 259\)](#).

[2] After passing the charge and discharge maintenance, if the outer box has a Maintaining Label, please update the maintenance information on the Maintaining Label. If there is no Maintaining Label, please record the maintenance time and battery SOC yourself and keep the data securely for maintaining maintenance records.

Battery Model	Initial SOC Range for Battery Storage	Recommended Storage Temperature	Charge/Discharge Maintenance Cycle ^[1]	Battery Maintenance Method ^[2]
GW5.1-BAT-D-G20	35~45%	0~35°C	-20~35°C, 12 months 35~45°C, 6 months	Please consult the distributor or after-sales service center for maintenance methods.
GW8.3-BAT-D-G20				
GW5.1-BAT-D-G21				
GW8.3-BAT-D-G21				

Packaging Requirements:

Ensure that the outer packaging box is not removed and the desiccant inside the box is not lost.

Environmental Requirements:

1. Ensure that the device is stored in a cool place, avoiding direct sunlight.
2. Ensure the storage environment is clean, with appropriate temperature and humidity ranges, and no condensation. If there is condensation on the device ports, do not install the device. Battery storage humidity range: 5%-95%.
3. Ensure that the device is stored away from flammable, explosive, corrosive, and

other hazardous materials.

Stacking Requirements:

1. Ensure that the stacking height and direction of the device are arranged according to the instructions on the packaging box label.
2. Ensure that there is no risk of tipping after the devices are stacked.

4 Installation

DANGER

When performing equipment installation and electrical connections, please use the delivery items shipped with the box. Otherwise, any resulting equipment damage will not be covered under warranty.

4.1 Installation Requirements

4.1.1 Installation Environment Requirements

NOTICE

- Inverter operating temperature range: -35°C to 60°C.
- GW5.1-BAT-D-G20, GW8.3-BAT-D-G20: Charging temperature range: -18°C to 55°C; Discharging temperature range: -20°C to 55°C. If installed in an environment below -18°C, the battery will be unable to recharge and restore energy after being depleted, resulting in battery undervoltage protection.
- GW5.1-BAT-D-G21, GW8.3-BAT-D-G21: Charging temperature range: 2°C to 55°C; Discharging temperature range: -20°C to 55°C. If installed in an environment below 2°C, the battery will be unable to recharge and restore energy after being depleted, resulting in battery undervoltage protection.

1. The equipment must not be installed in flammable, explosive, corrosive, or similar environments.
2. The temperature and humidity of the installation environment must be within a suitable range.
3. The installation location must be out of reach of children and avoid easily accessible positions.
4. The equipment surface may become hot during operation to prevent burns.
5. The equipment must be installed away from direct sunlight, rain, snow accumulation, etc. It is recommended to install in a sheltered location; a sunshade can be built if necessary.
6. The installation space must meet the equipment's ventilation, heat dissipation, and

operational space requirements.

7. The installation environment must meet the equipment's protection rating. The Inverter, battery, and smart communication stick are suitable for indoor and outdoor installation; the meter is suitable for indoor installation.
8. The installation height of the equipment should facilitate operation and maintenance, ensuring the indicator lights, all labels are easily visible, and the wiring terminals are easy to operate.
9. The installation altitude of the equipment should be lower than the maximum operating altitude.
10. For outdoor installation in salt damage areas, please consult the equipment manufacturer. Salt damage areas mainly refer to regions within 500m of the coast. The affected area is related to sea wind, precipitation, terrain, and other conditions.
11. The equipment generates noise during operation. The installation location should be away from areas highly sensitive to noise, such as residential living areas, schools, hospitals, etc., to avoid disturbance to people living nearby caused by operational noise.
12. Keep away from strong magnetic field environments to avoid electromagnetic interference. If there are radio stations or wireless communication equipment below 30MHz near the installation site, install the equipment according to the following requirements:
 - Inverter: Add ferrite cores with multiple turns on the DC input or AC output lines of the Inverter, or add a low-pass EMI filter; or maintain a distance of over 30m between the Inverter and the wireless electromagnetic interference equipment.
 - Other equipment: Maintain a distance of over 30m between the equipment and the wireless electromagnetic interference equipment.

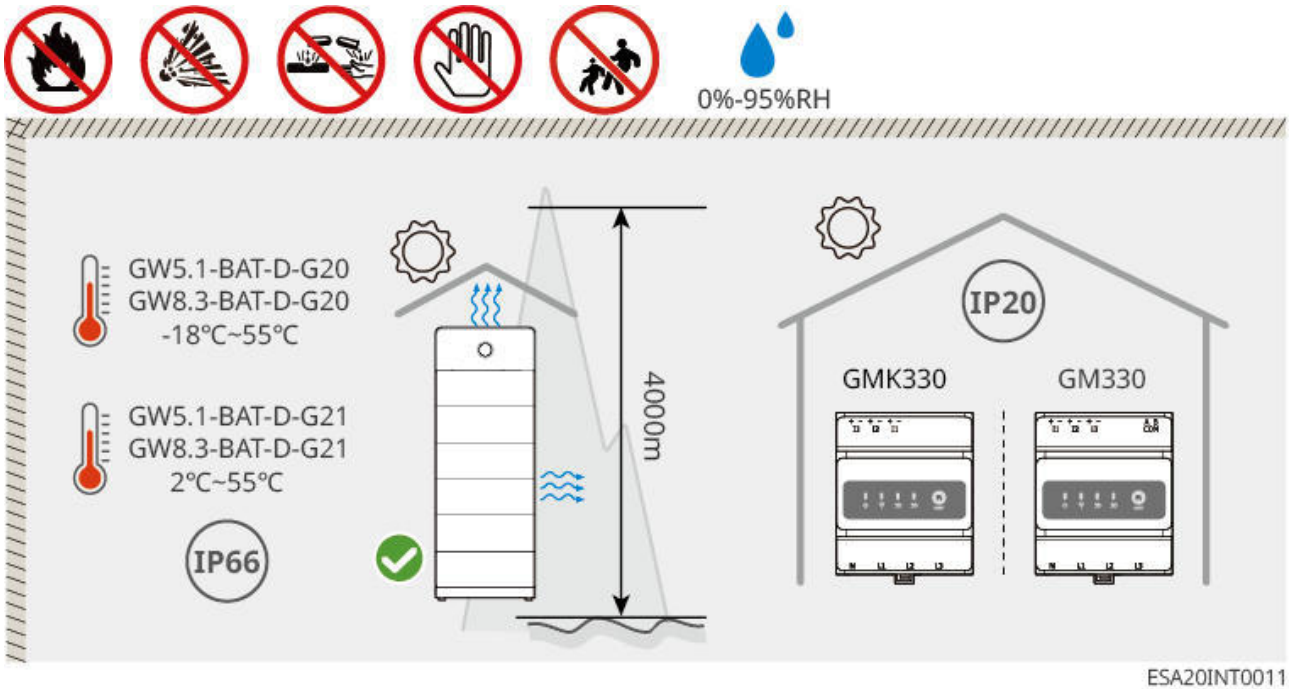

4.1.2 Installation Space Requirements

When installing equipment in the system, sufficient space should be reserved around the equipment to ensure adequate installation and heat dissipation space.

- CAT 5E or above shielded network cable is required for CT installation, with a cable distance not exceeding 30 meters.
- The RS485 twisted-pair shielded cable for communication between the inverter and the electric meter should not exceed 100 meters in length.

Cable Specifications

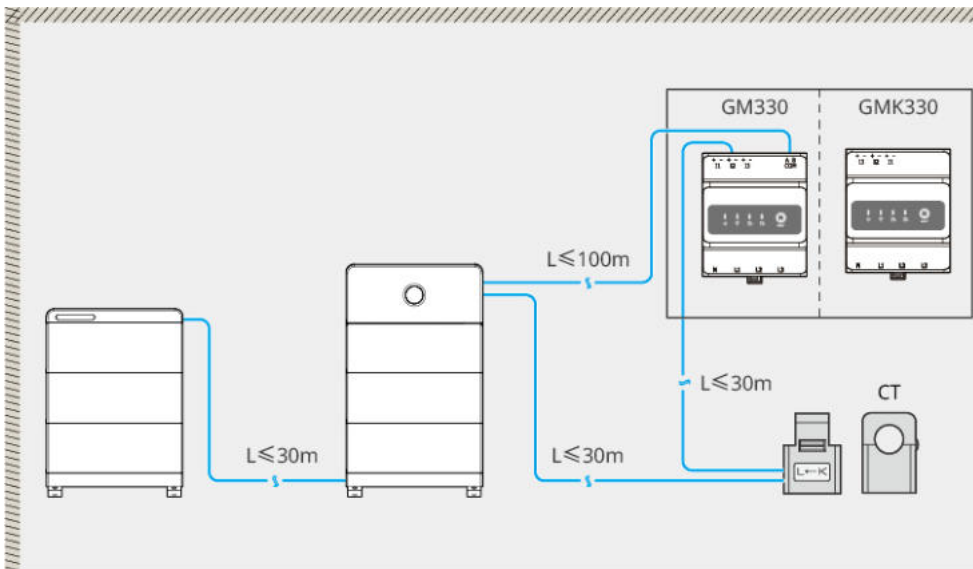

ESA20INT0012

Cable Specifications

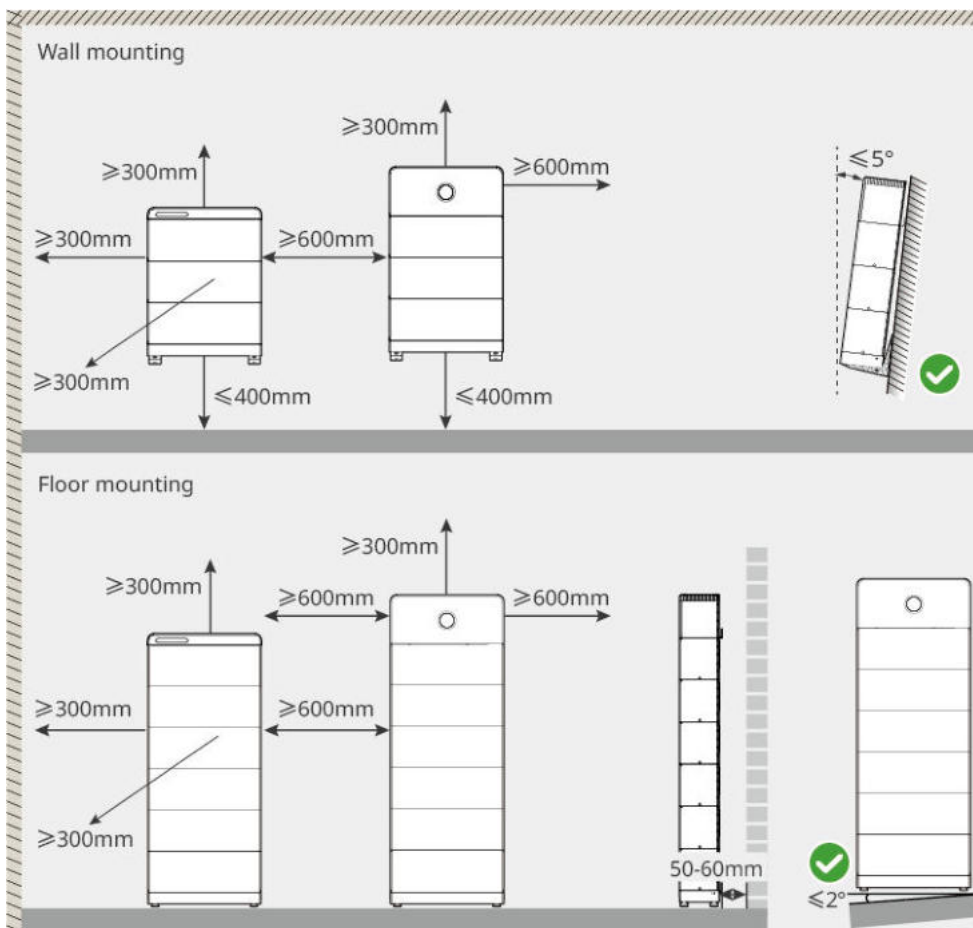

ESA20INT0018



4.1.3 Tool Requirements

NOTICE



During installation, it is recommended to use the following installation tools. If necessary, other auxiliary tools may be used on-site.

Installation Tools

Tool Type	Description	Tool Type	Description
	diagonal plier		RJ45 connector crimping tool
	wire stripper		Level bar
	open-end wrench		PV terminal crimping tool PV-CZM-61100
	hammer drill (drill bit Φ12mm)		torque wrench M4, M5, M6, M10
	rubber hammer		socket wrench
	marker pen		multimeter Range ≤ 1000V
	heat shrink tubing		heat gun

Tool Type	Description	Tool Type	Description
	cable tie		vacuum cleaner

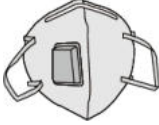
Personal Protective Equipment

Tool Type	Description	Tool Type	Description
	Insulated gloves, protective gloves		Dust mask
	goggle		Safety shoes

4.2 Equipment Handling

 CAUTION

- When drilling holes, ensure the drilling location avoids water pipes, cables, etc., inside the wall to prevent danger.
- When drilling, please wear safety goggles and a dust mask to prevent dust from being inhaled into the respiratory tract or falling into the eyes.
- The inverter must be installed above the battery; do not install the battery above the inverter.
- When installing the battery system, ensure it is level and secure. When placing the battery base, battery, and inverter, confirm that the holes on the upper and lower layers are aligned; the anti-tipping bracket should be vertical and tightly attached to the ground, wall, or battery system surface.
- When using an impact drill to make holes, use cardboard or other coverings to shield the battery system to prevent foreign objects from entering the equipment and causing damage.
- For wall-mounted installation, to ensure the safety of your life and property, be sure to assess the wall's load-bearing capacity.

NOTICE

- The battery must be installed on the base, which can be floor-mounted or bracket-mounted.
- For floor installation, a maximum of 4 batteries can be stacked when away from the wall, and a maximum of 6 batteries can be stacked when against the wall.
- The maximum stacking quantities for bracket installation are as follows:
 - Same capacity stacking:
 - GW5.1-BAT-D-G20 and GW5.1-BAT-D-G21: Maximum of 3 units.
 - GW8.3-BAT-D-G20 and GW8.3-BAT-D-G21: Maximum of 2 units.
 - Mixed capacity stacking:
 - When GW5.1-BAT-D-G20, GW5.1-BAT-D-G21 are mixed with GW8.3-BAT-D-G20, GW8.3-BAT-D-G21 for stacking, the system supports a maximum of 2 units per group.
- When installing against a wall, the base, bracket, and top battery must be secured to the wall using an anti-tip bracket.
- When marking drilling positions for bracket installation, have one person steady the base while another uses a marker to mark the drilling spots.
- When installing batteries and the inverter, remove the protective covers from the blind-mate connectors before stacking.

Wall Mounting

Step 1: Install the base onto the wall bracket.

Step 2: Place the wall bracket flush against the wall. Ensure the bracket is securely positioned, observing the level bubble in the center of the base.

Step 3: After adjusting the position and level of the wall bracket, use a marker to mark the drilling positions. After marking, remove the wall bracket. (A: PACK fixing hole positions; B: Bracket fixing hole positions.)

Step 4: Drill holes and install expansion bolts.

1. Use an impact drill to drill holes.
2. Clean the holes.
3. Use a rubber mallet to install the expansion bolts into the holes.
4. Use a hex wrench to tighten the nut clockwise to expand the bolt.
5. Rotate the nut counterclockwise to remove it.
6. Use a torque screwdriver to secure the anti-tipping bracket to the wall.

Step 5: Use a hex wrench to secure the wall bracket to the wall.

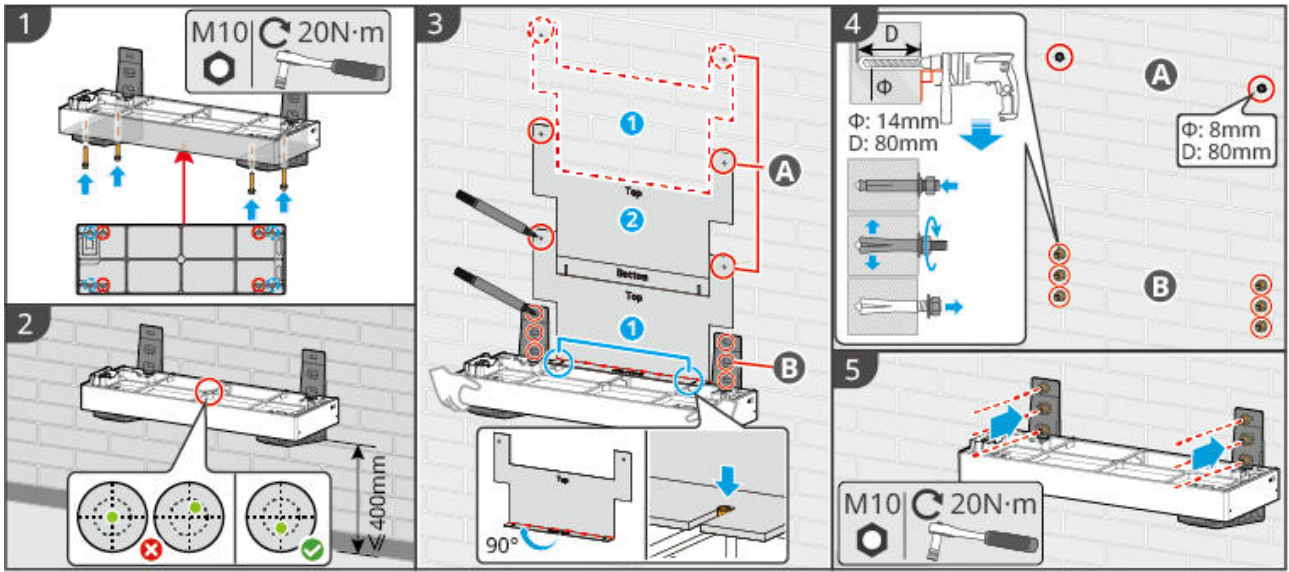

Floor Installation

Installation Against Wall

Step 1: Install the adjustable feet onto the bottom of the base, and secure the anti-tipping bracket to the base.

Step 2: Place the base 50-60mm away from the wall, keeping it parallel to the wall. Observe the level bubble in the center of the base; if it is not centered, use the adjustable feet to level it.

Step 3: After adjusting the position and level of the base, use drilling marking paper to mark the drilling positions. After marking, remove the base. (A: PACK fixing hole positions; B: Bracket fixing hole positions.)

Step 4: Use an impact drill to drill holes, and clean the holes.

Step 5: Use a Phillips screwdriver to secure the anti-tipping bracket to the wall.

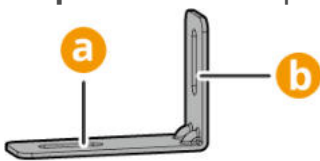

a: Surface fixed to the base; b: Surface fixed to the wall.

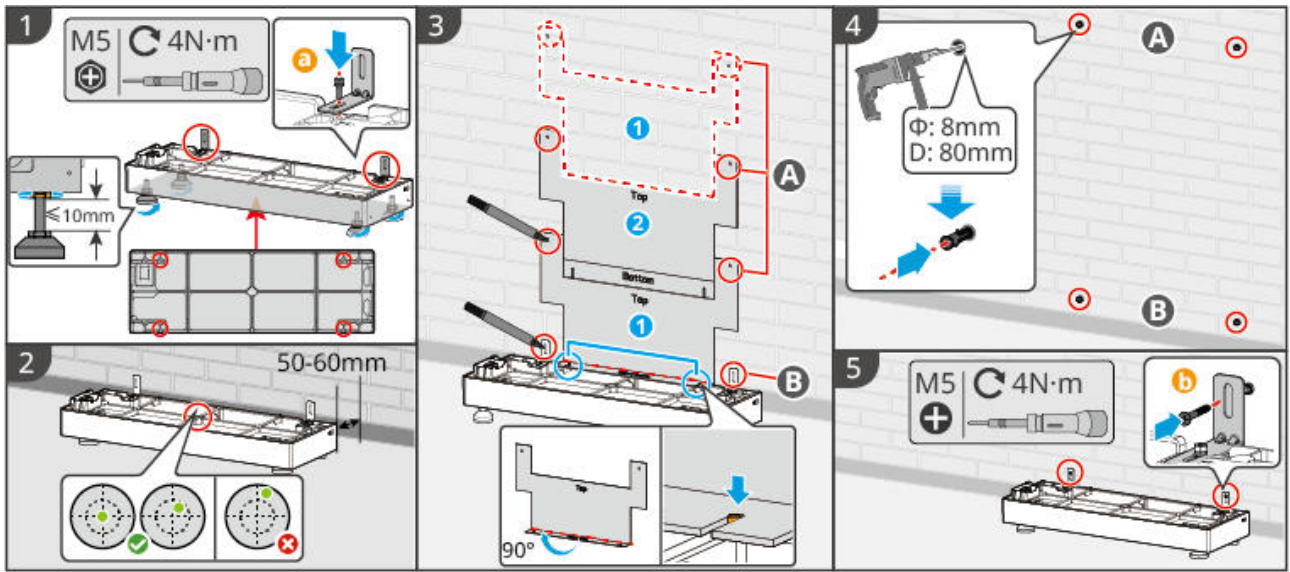

ESA20INT0004

Freestanding Installation (Away from Wall)

Step 1: Install the adjustable feet onto the bottom of the base. Observe the level bubble in the center of the base; if it is not centered, use the adjustable feet to level it.

Step 2: After adjusting the position and level of the base, secure the freestanding installation bracket to the base. Choose a suitable location to mark the drilling positions. After marking, remove the base.

Step 3: Drill holes and install expansion bolts.

1. Use an impact drill to drill holes.
2. Clean the holes.
3. Use a rubber mallet to install the expansion bolts into the holes.
4. Use a hex wrench to tighten the nut clockwise to expand the bolt.
5. Rotate the nut counterclockwise to remove it.
6. Use a torque screwdriver to secure the anti-tipping bracket (for freestanding) to the floor.

Step 4: Use a hex wrench to secure the base to the floor.

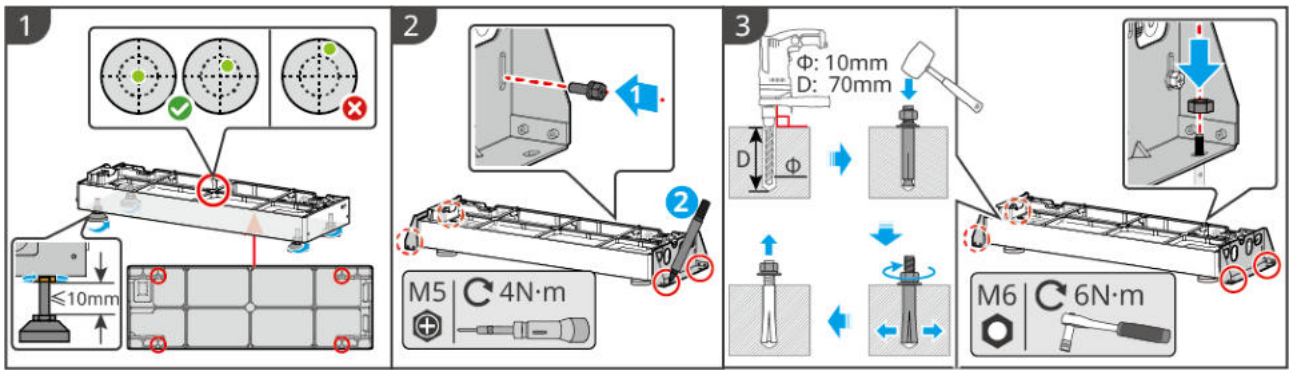

ESA20INT0015

Installing Battery and Inverter

NOTICE

When wall-mounted, the topmost battery must be secured to the wall using an anti-tipping bracket.

Step 1: Remove the protective cover from the blind-mate connector on the bottom of the inverter or battery.

Step 2: Install the handle (optional), and stack the battery onto the base.

If installing more than 3 batteries, use lifting equipment.

Step 3: Tighten the screws between the battery and the base or between batteries.

If installing multiple batteries, repeat **Step 1** and **Step 2** to complete the installation of all batteries. The number of stacked batteries must comply with the "[2.2.1.System Overall Configuration Description\(Page 33\)](#)".

Step 4: (Optional) Secure the topmost battery to the wall using an anti-tipping bracket.

Step 5: Install the inverter or battery decorative cover.

- Integrated Installation: Lift the inverter, align it, and stack it on top of the battery. Tighten the screws between the inverter and the battery. If the system is an integrated configuration, the installation is now complete.
- Split-type Expansion: Repeat the battery installation steps. After completing the electrical connections, place the battery decorative cover on top of the battery and tighten the side screws.

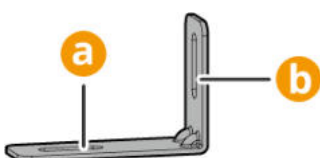

a: Surface fixed to the PACK; b: Surface fixed to the wall.

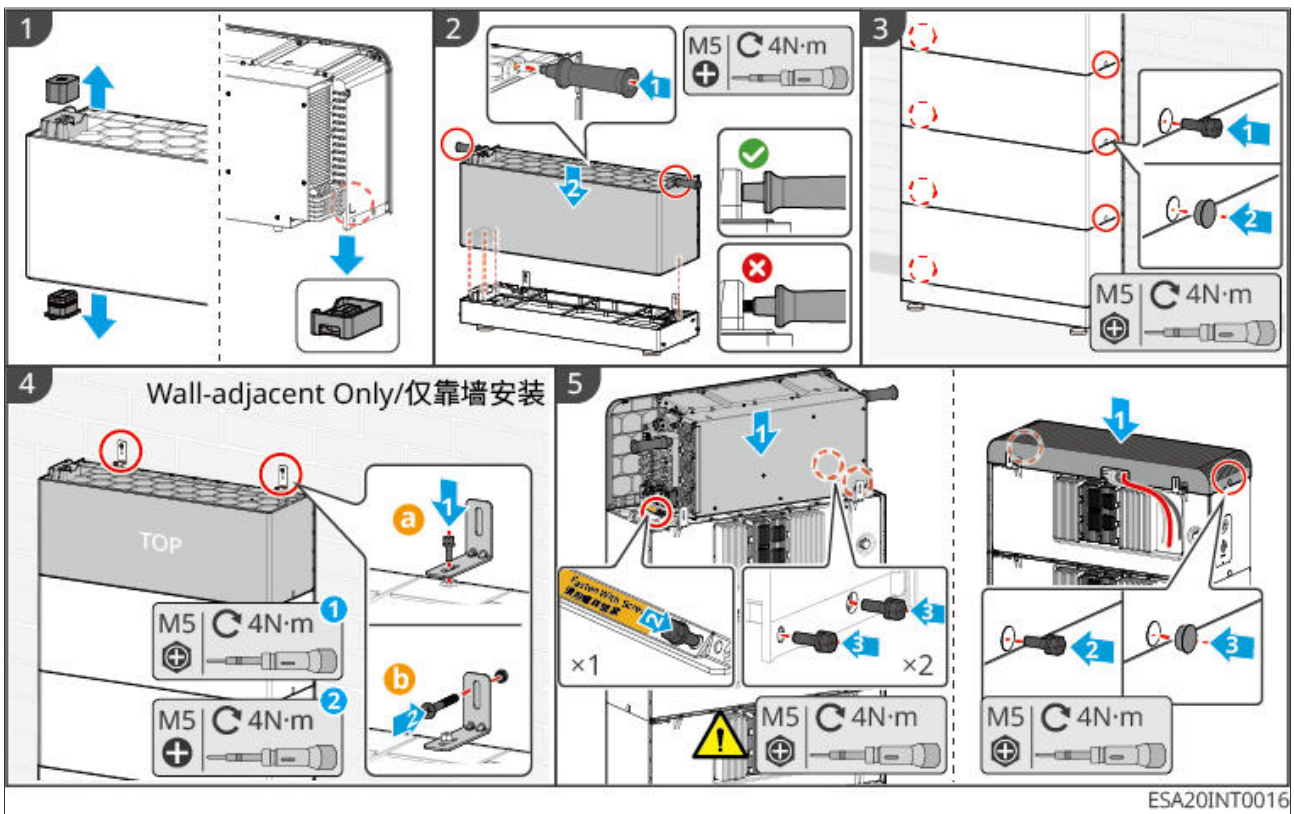

4.4 Installing the Smart Meter

⚠ WARNING

In areas with lightning danger, if the meter cable length exceeds 10m and the cable is not laid with grounded metal conduit, it is recommended to install external lightning protection devices.

GM330&GMK330

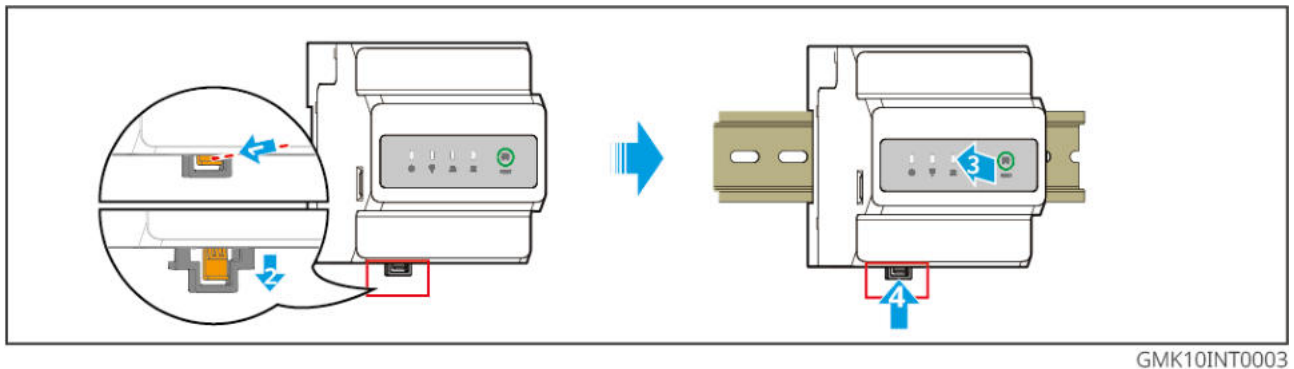

5 System Wirings

 **DANGER**

- The installation, routing, and connection of cables must comply with local laws, regulations, and code requirements.
- All operations during electrical connection, as well as the specifications of cables and components used, must meet local legal and regulatory requirements.
- Before performing electrical connections, disconnect the DC switch and AC output switch of the equipment to ensure it is powered off. Live working is strictly prohibited, as it may lead to hazards such as electric shock.
- Cables of the same type should be bundled together and arranged separately from different types of cables. Intertwining or cross-routing is prohibited.
- If cables are subjected to excessive tension, poor connections may result. During wiring, leave a certain length of cable slack before connecting to the inverter terminals.
- When crimping terminals, ensure the conductor part of the cable makes full contact with the terminal. Do not crimp the cable insulation together with the terminal, as this may cause the equipment to malfunction, or lead to overheating and damage to the inverter terminal block due to unreliable connections during operation.
- The inverter is not tested to AS/NZS 4777.2:2020 for combinations and/or multiple phase inverter combinations so that combinations should not be used.
- Unused cable entry holes and ports (including communication ports) must be reliably sealed using the dedicated terminal blocks or plugs provided in the accessory kit. Failure to do so may result in the following risks:
 - Electric Shock Hazard: Open electrical ports may allow direct contact with live parts, leading to electric shock accidents.
 - Protection Failure: Open ports can allow dust, moisture, or foreign objects to enter, potentially causing short circuits, fires, or equipment failure.

NOTICE

- When performing electrical connections, wear personal protective equipment such as safety shoes, protective gloves, and insulating gloves as required.
- Only qualified personnel are permitted to perform electrical connection operations.
- The cable colors shown in the graphics in this document are for reference only. Actual cable specifications must comply with local regulations.

5.1 System Wiring Electrical Block Diagram

NOTICE

- Depending on regional regulatory requirements, the wiring methods for the N and PE lines of the inverter's GRID and BACK-UP ports may differ. Please comply with local regulations.
- The inverter has a built-in energy meter and can be directly connected to a CT for use. The CT network cable included in the shipment is 10 meters. For longer distances, you can use shielded network cable of CAT5E or higher grade to extend it up to 30 meters.
- CT accuracy will decrease when the connection length to the inverter exceeds 30m. For higher accuracy requirements, an external smart meter can be connected.
- The inverter's GRID AC port has a built-in relay. When the inverter is in off-grid mode, the built-in GRID relay is open; when the inverter is in grid-connected mode, the built-in GRID relay is closed.
- When the inverter is powered on, the BACK-UP AC port is live. If maintenance on the BACK-UP Loads is required, please power down the inverter to avoid electric shock.
- In a whole-house backup scenario, if the total power of the connected loads exceeds 1.1 times the inverter's rated power, the inverter will stop outputting due to overload protection after a grid outage. In this case, please turn off some non-essential loads to ensure the total load power is less than 1.1 times the inverter's rated power.

N and PE lines are connected together in the distribution box

NOTICE

- To maintain neutral integrity, the neutral lines of the grid-connected side and the off-grid side must be connected together; otherwise, the off-grid function cannot operate normally.
- The diagram below illustrates the grid system for regions such as Australia and New Zealand:

Whole-house backup power

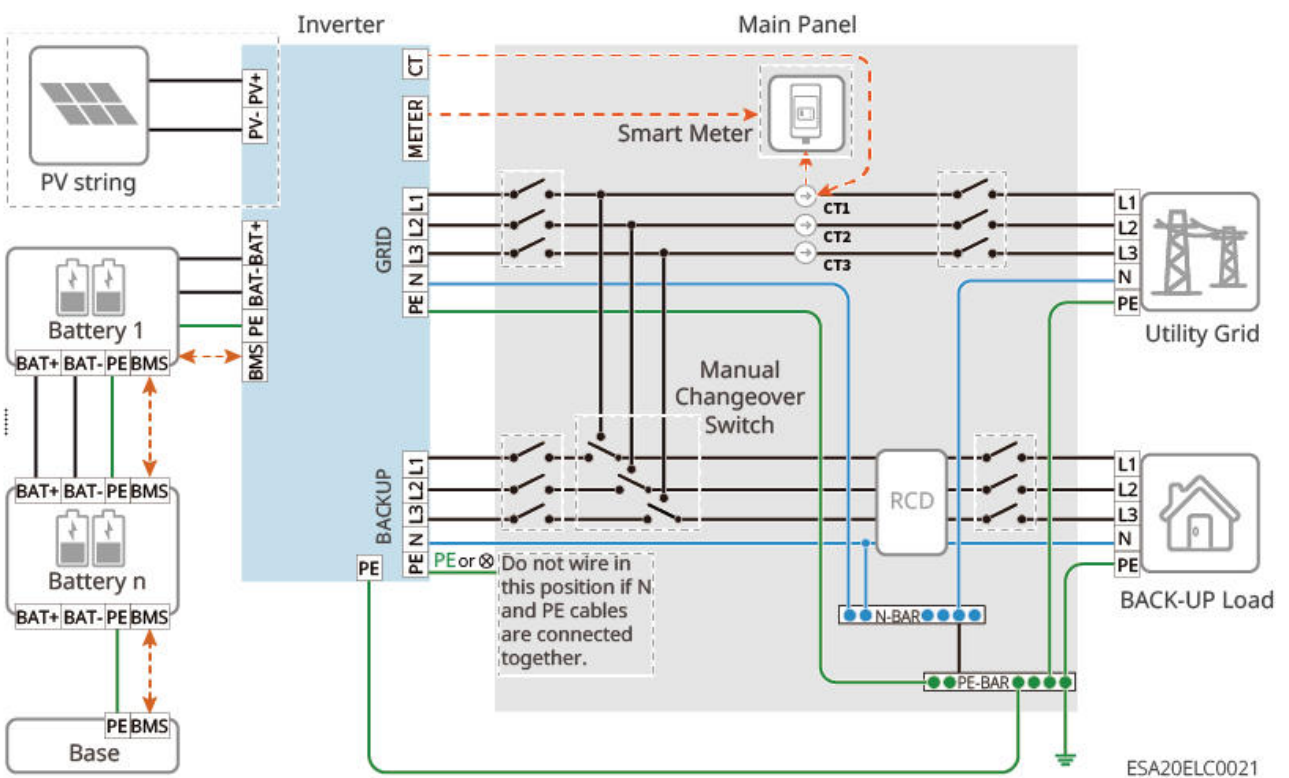

Partial backup power

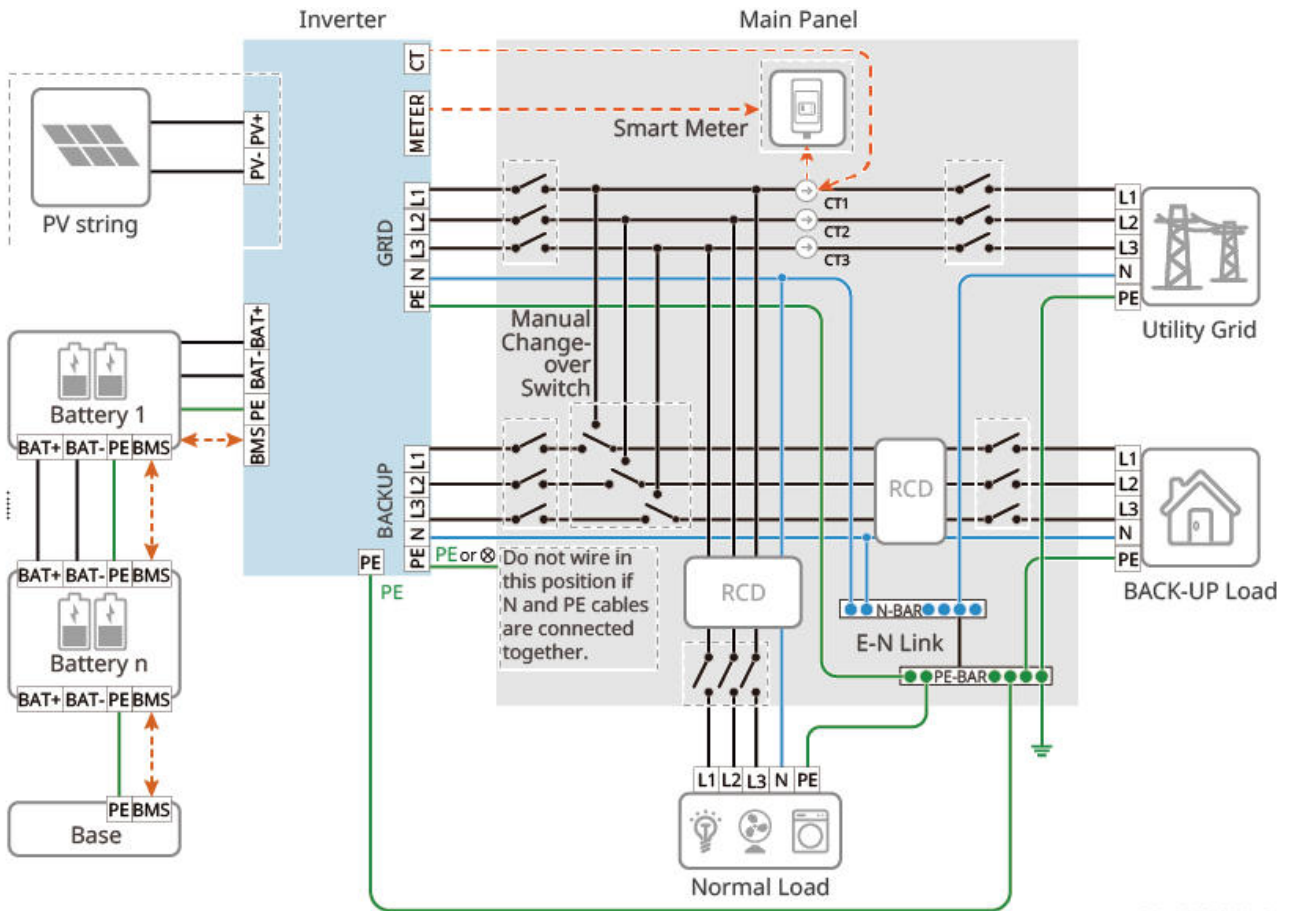

ESA20ELC0015

N and PE lines are wired separately in the distribution box

NOTICE

- Please ensure that the protective ground wire of BACK-UP is correctly and securely connected; otherwise, the BACK-UP function may malfunction when a grid fault occurs.
- Other regions except Australia, New Zealand, etc. are applicable to the following wiring methods:

Whole-house backup power

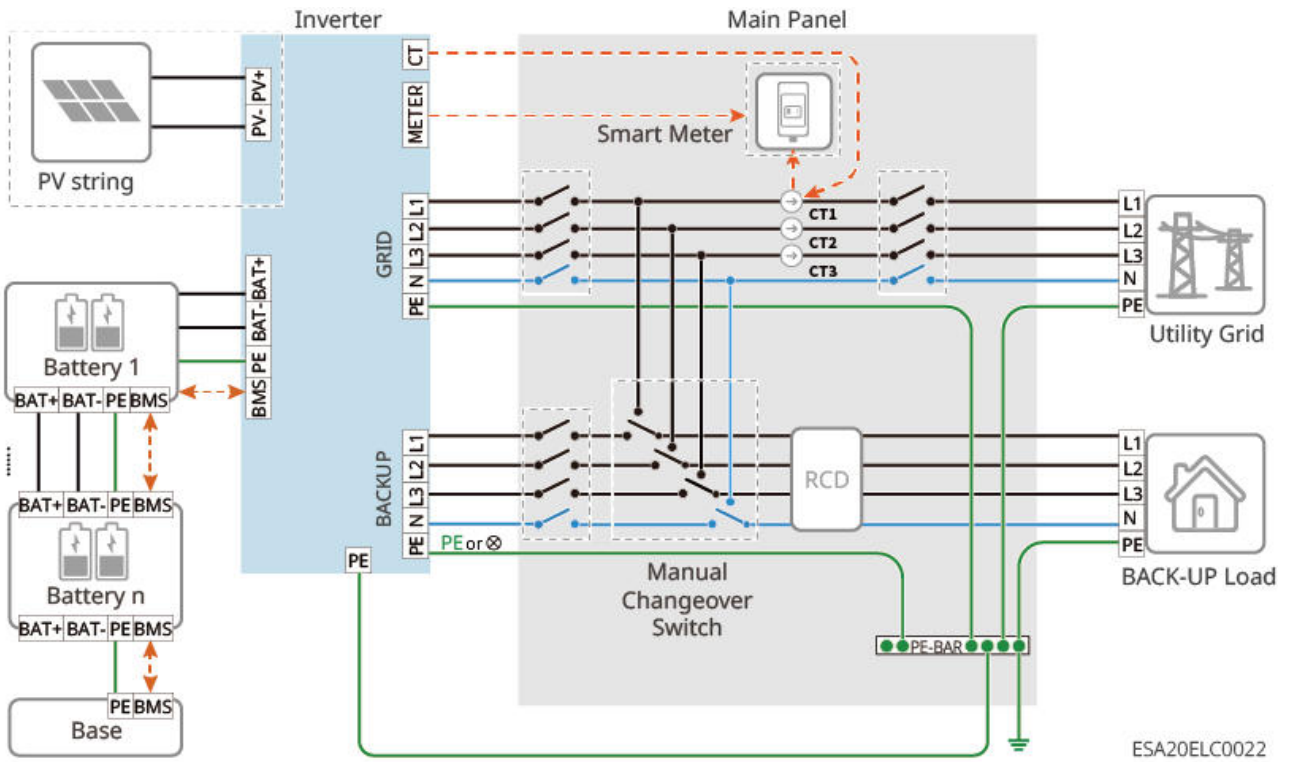

Partial backup power

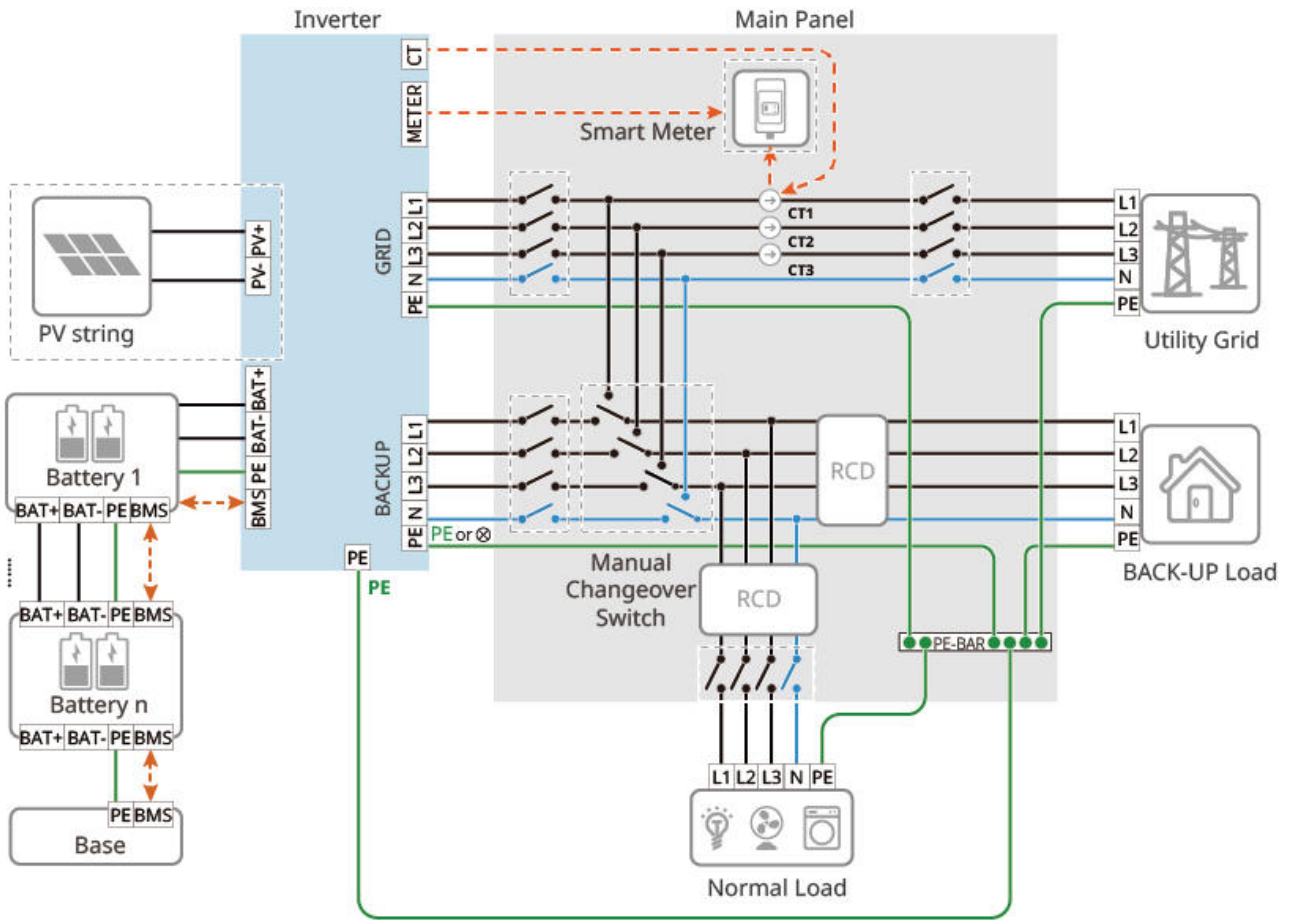

ESA20ELC0016

5.2 Detailed System Wiring Diagram

When all loads in the photovoltaic system cannot consume the electricity generated by the system, the surplus electricity will be fed into the grid. In this case, a smart meter or CT monitoring system can be used to monitor the system's power generation and control the amount of electricity fed into the grid.

- Connecting a smart meter enables output power limiting and load monitoring functions.
- After connecting the smart meter, please enable the "Export power limit" function via the SEMS+ App.

The Detailed System Wiring Diagram only shows wiring examples using some model devices. Please refer to the corresponding wiring guide chapter for the actual devices you are using for wiring.

⚠ WARNING

The common contact of the manual transfer switch must be at the Inverter's BACK-UP load side, do not connect to the GRID grid side. If connected to the GRID grid side, the Inverter's off-grid mode and bypass mode operate simultaneously, when the grid power is out, the distribution cabinet connected to the Inverter's GRID port still has high voltage electricity, there may be a risk of electric shock.

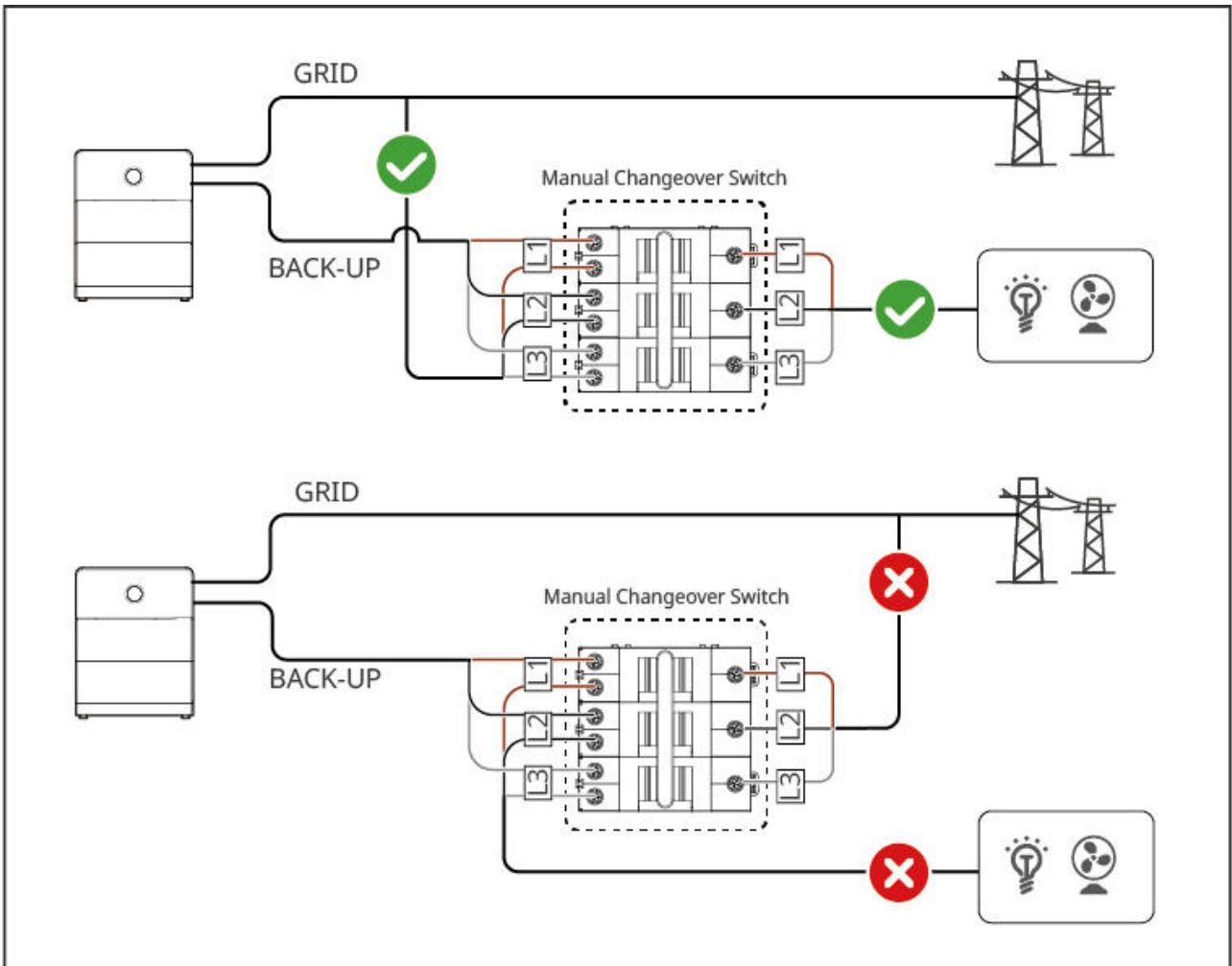

ESA20ELC0019

NOTICE

- In microgrid and coupling scenarios, if grid-tied inverter power generation monitoring and load monitoring functions are required, dual-meter networking must be used.
 - Meter 1 or the built-in meter is used to monitor the system's grid-connected power.
 - Meter 2 is used to monitor the grid-tied inverter's power generation.
 - By integrating data from Meter 1 and Meter 2, the monitoring platform can achieve real-time monitoring of load power consumption.
- If output power limitation is required for the grid-tied inverter, please connect separate equipment such as a meter or CT.
- In microgrid and coupling scenarios configured with dual meters, the meter wiring method is the same.
- When not using the inverter's built-in meter, do not connect to the inverter's CT port.
- The manual transfer switch is shipped as an optional accessory; please decide whether to install it based on the actual usage scenario. If using a self-provided ATS or STS switch, this switch must have an interlock function.

Dual Meter Configuration Scenarios

Meter 1 (Grid Side)	Meter 2 (Grid-tied Inverter AC Side)
Built-in Meter	GMK330
Built-in Meter	GM330
GMK330	GMK330
GM330	GM330
GMK330	GM330
GM330	GMK330

General Scenario

Scenario with Built-in Meter

The scenario with a built-in meter does not support connecting a generator.

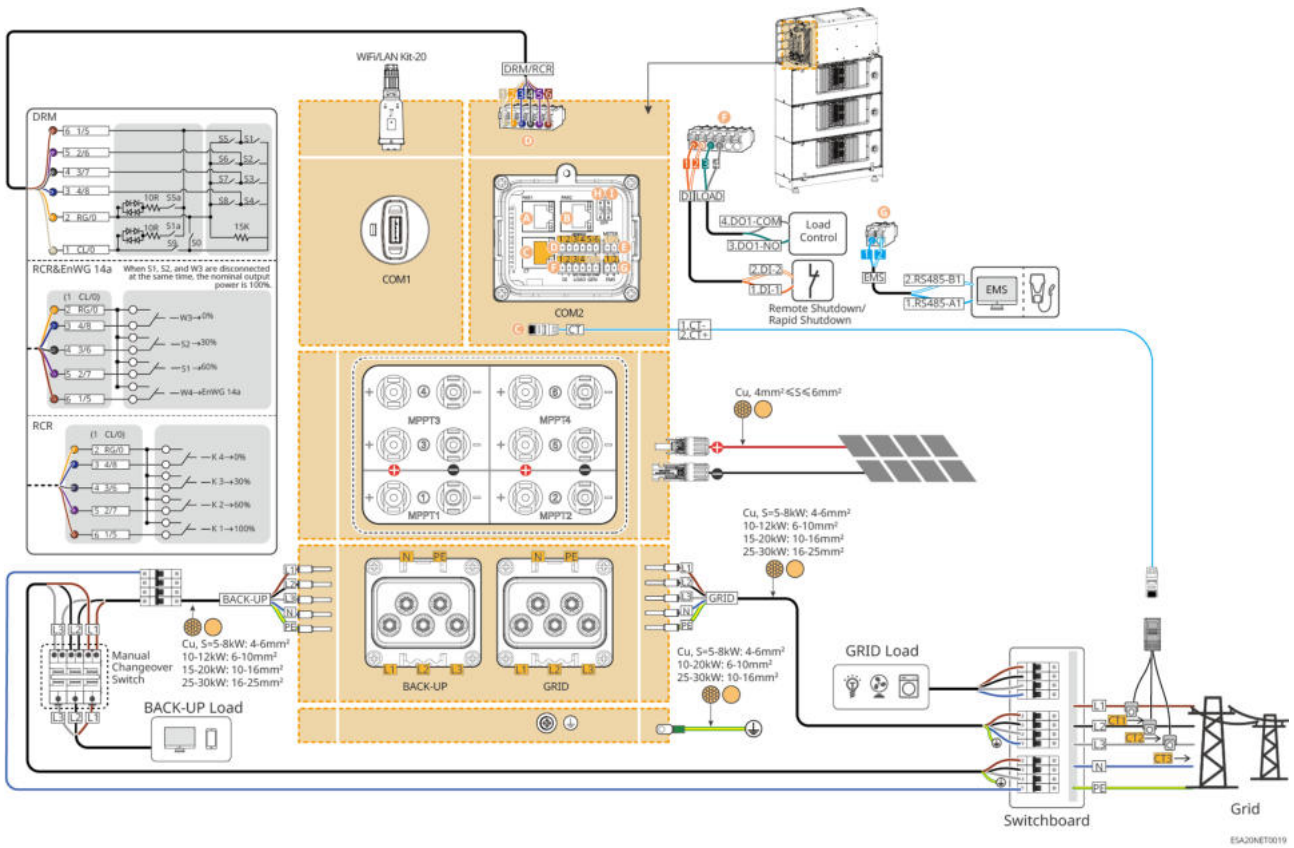

Scenario with GM330 Meter

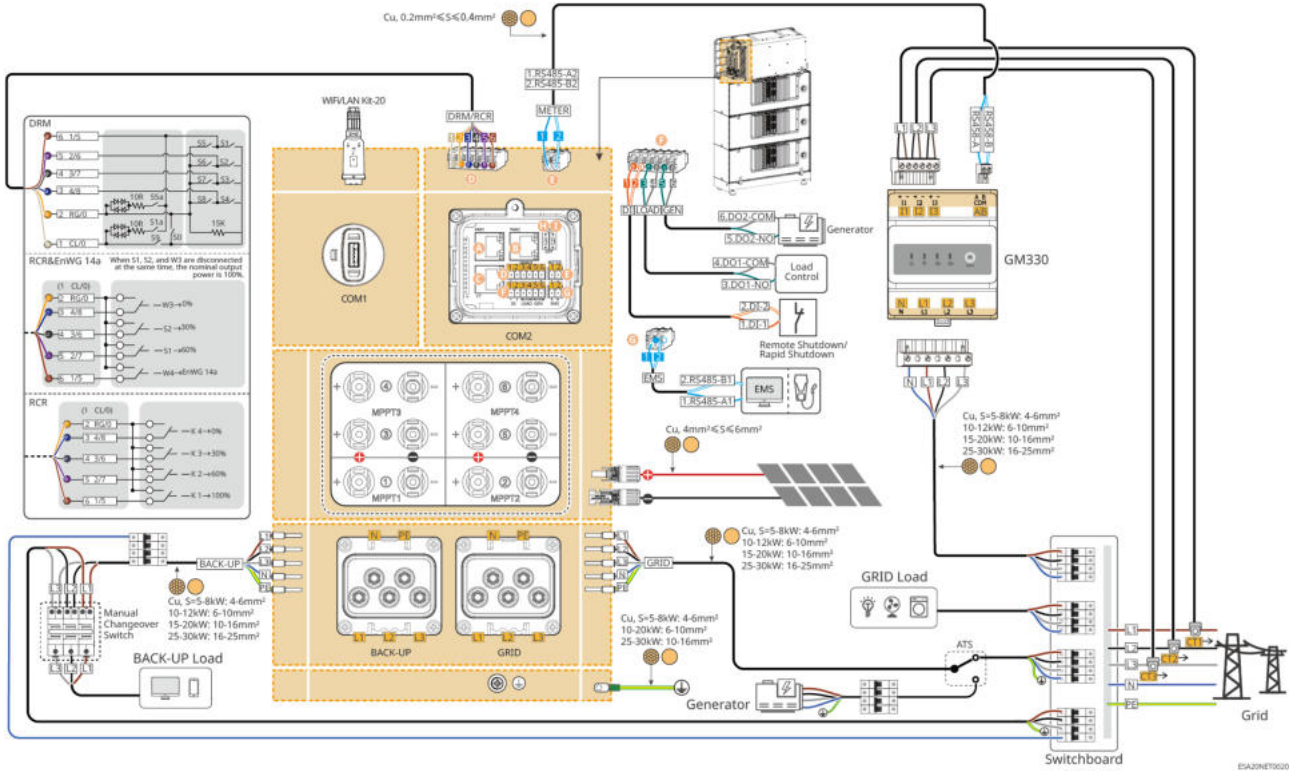

Scenario with GMK330 Meter

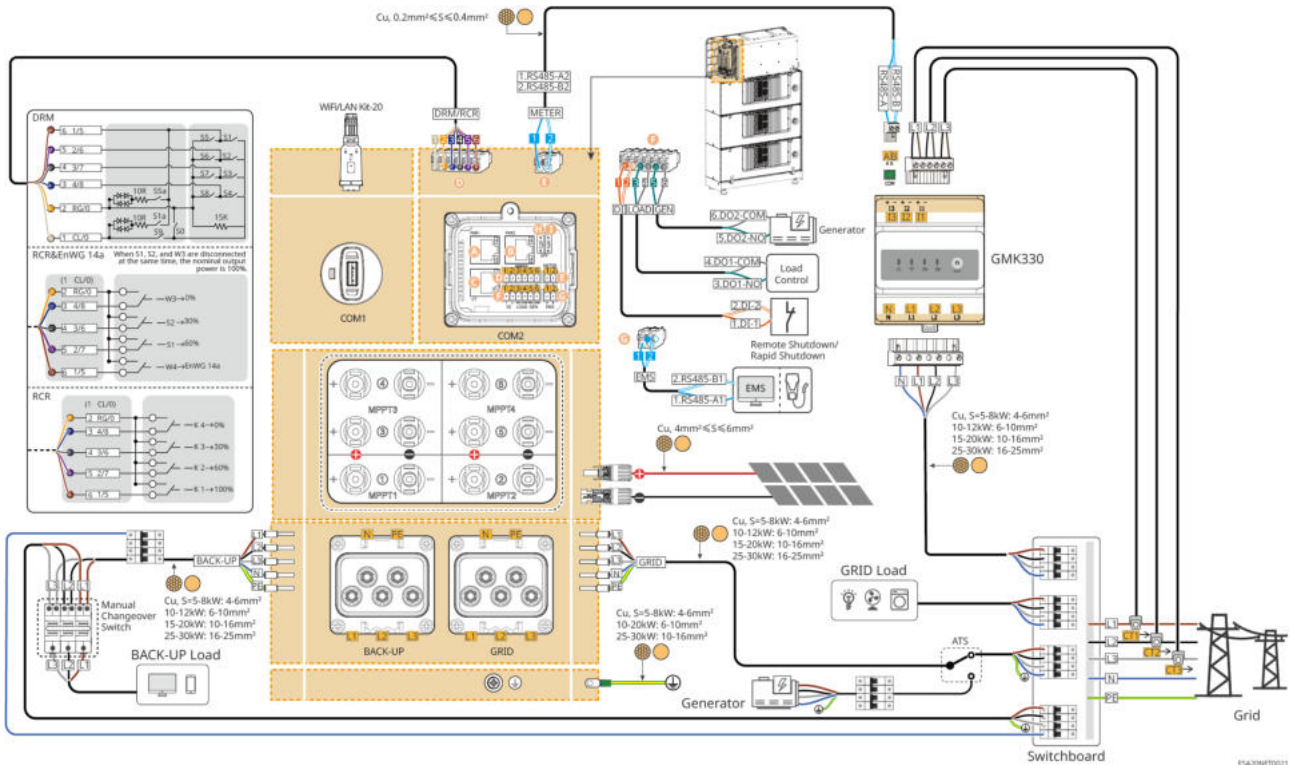

Microgrid Scenario Network Diagram

- The Microgrid Scenario does not support connecting a generator.
- The manual transfer switch is optional. Please choose whether to install it based on the actual usage scenario.

Built-in Meter + GM330 Meter Network Diagram

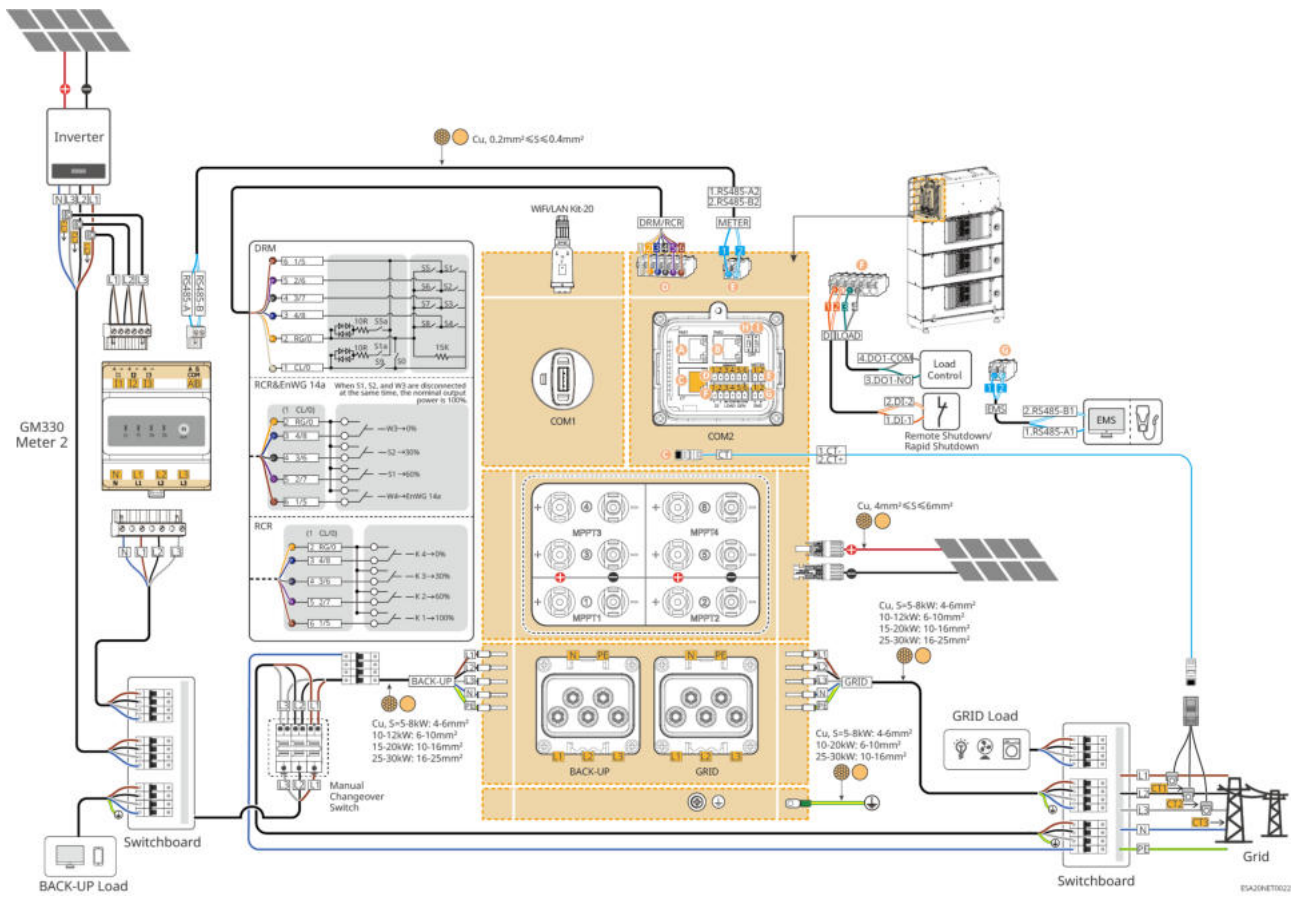

GMK330 + GMK330

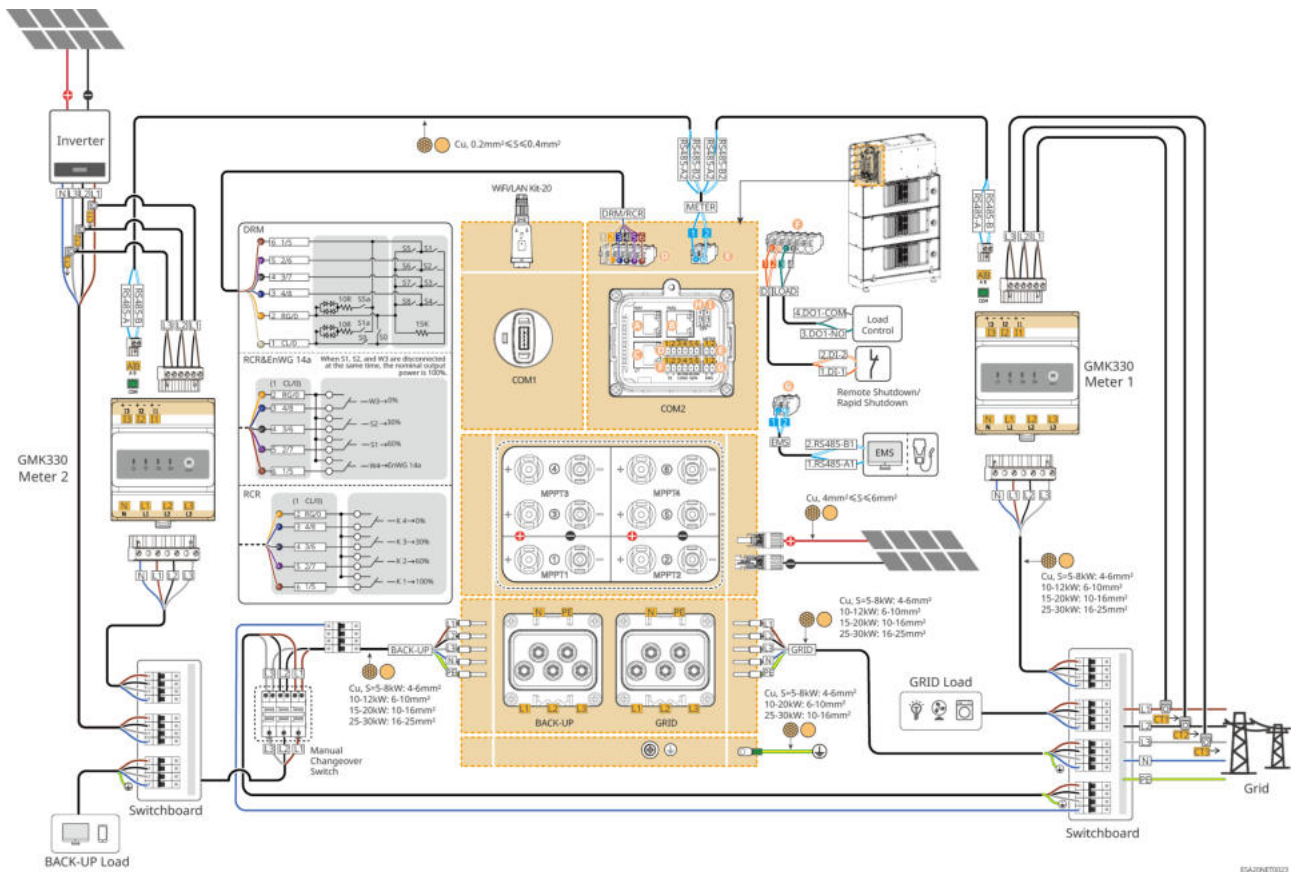

Microgrid Scenario, Grid-tied Inverter Export Power Limit Network Diagram

If output power limiting is required for grid-tied inverters in a Microgrid Scenario, please connect a meter or CT device separately.

GM330 + GMK330

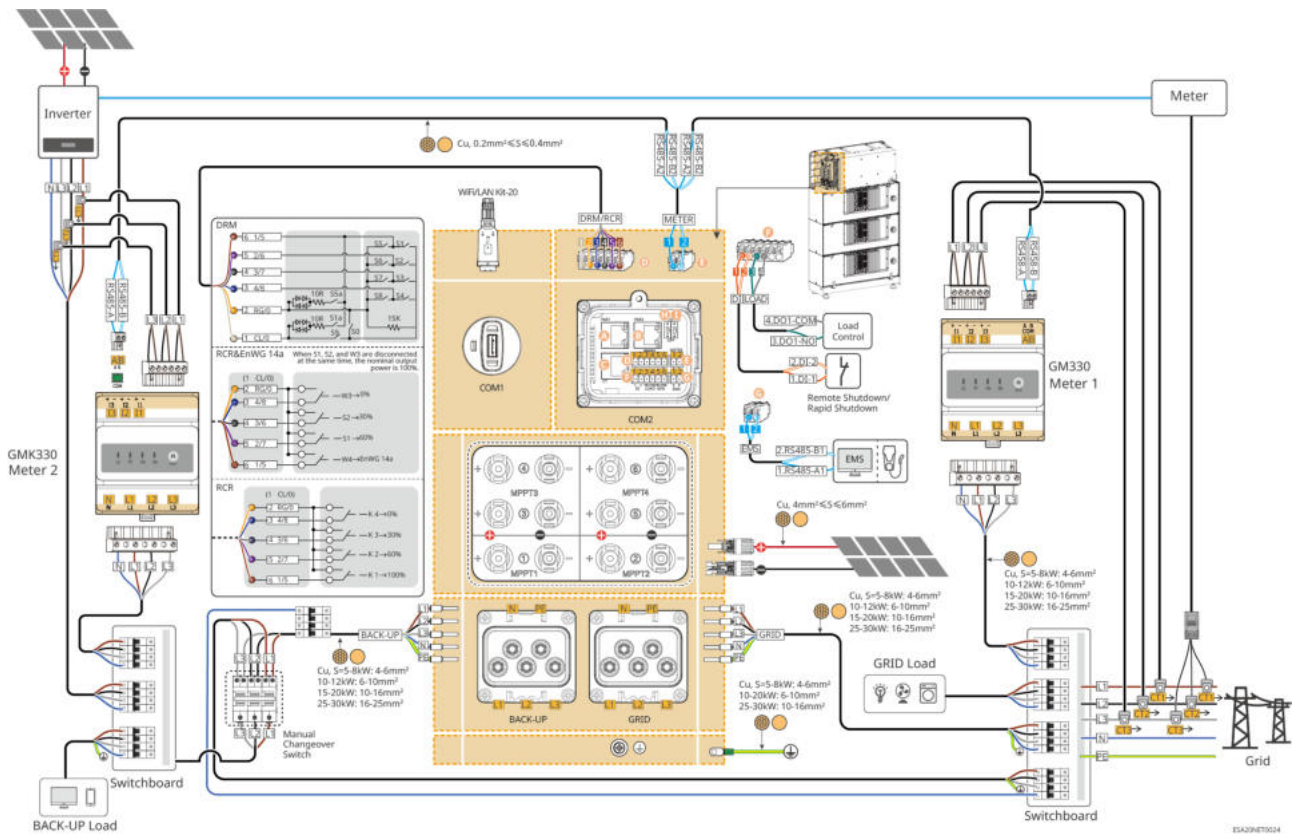

Coupled Scenario Dual Meter Network Diagram

- The manual transfer switch is optional. Please choose whether to install it based on the actual usage scenario.
- The scenario with a built-in meter does not support connecting a generator.

Built-in Meter + GMK330

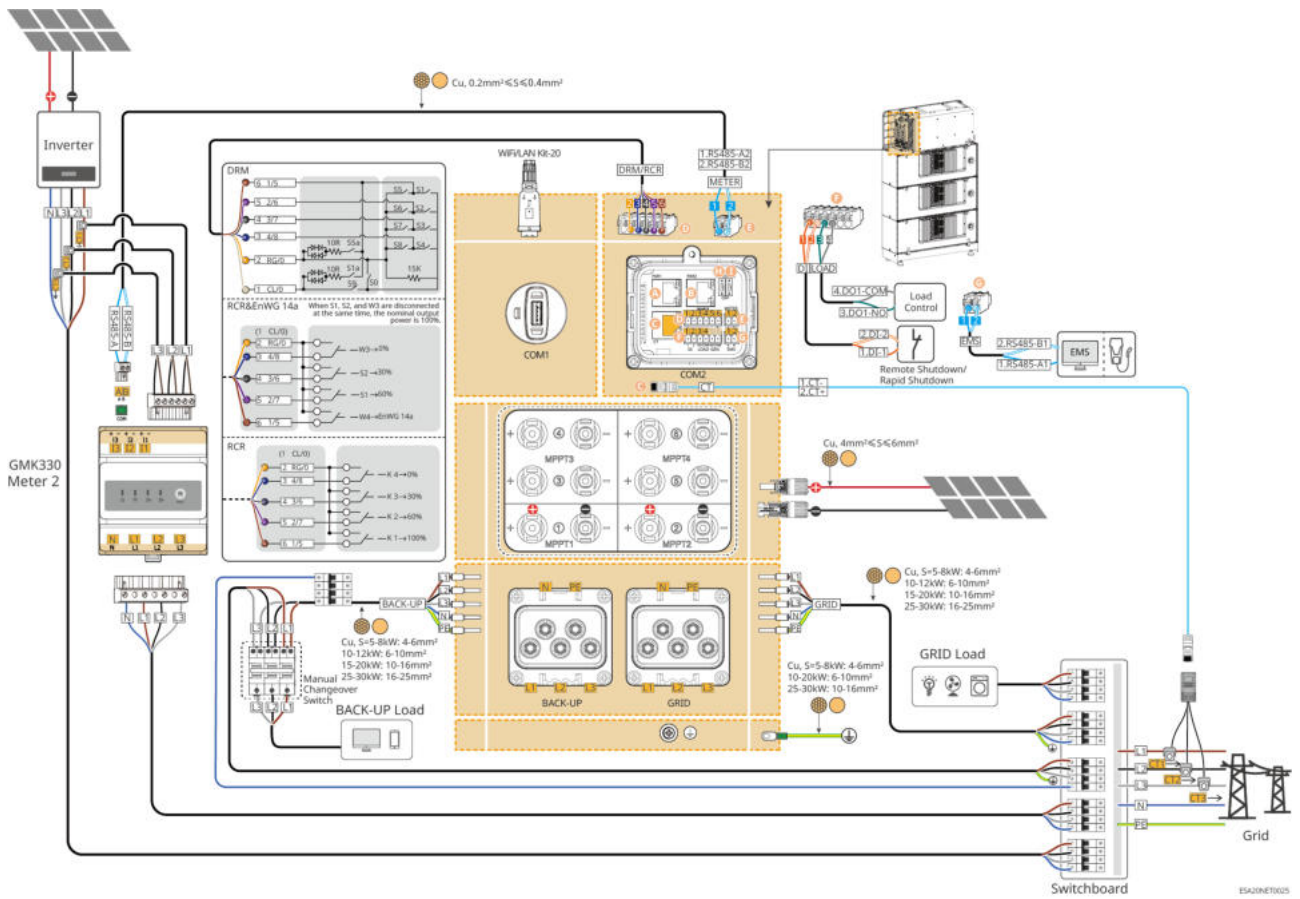

GM330 + GM330 Network Diagram

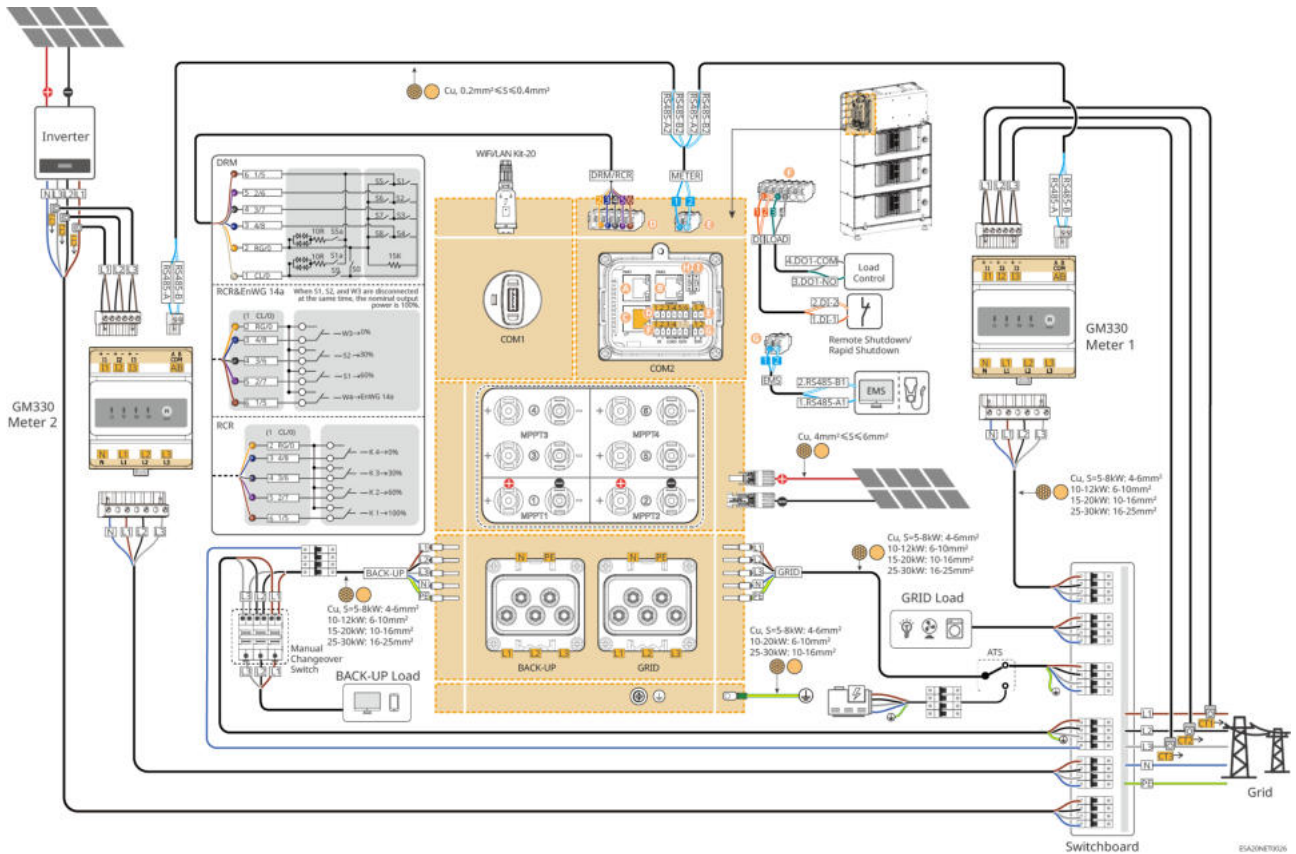

Coupled Scenario, Grid-tied Inverter Export Power Limit Network Diagram

If output power limiting is required for grid-tied inverters in a Coupled Scenario, please connect a meter or CT device separately.

GMK330 + GM330

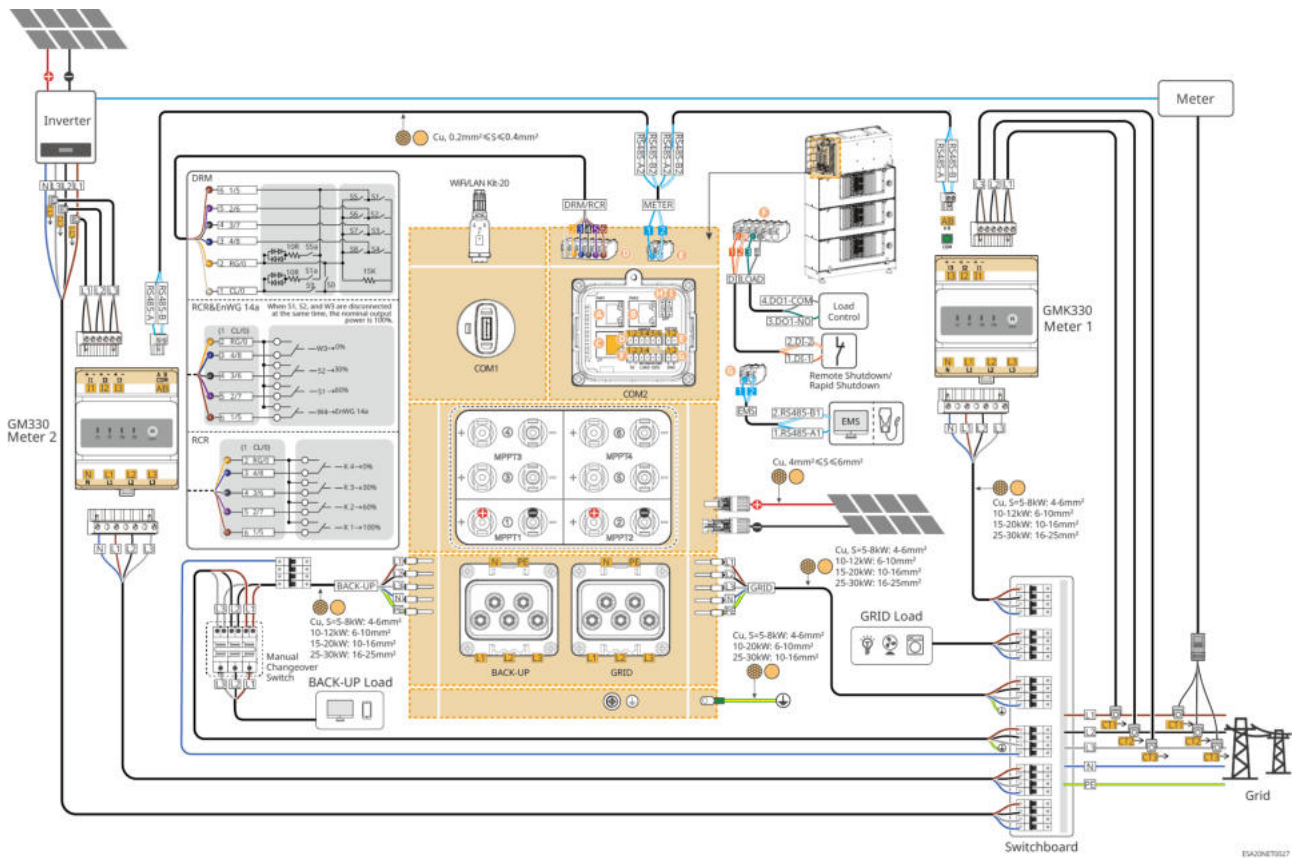

5.3 Preparing Materials

⚠ WARNING

- Do not connect loads between the inverter and the AC switch directly connected to the inverter.
- Each inverter must be equipped with an AC output circuit breaker. Multiple inverters cannot be connected to one AC circuit breaker simultaneously.
- To ensure that the inverter can safely disconnect from the grid in case of abnormalities, please connect an AC circuit breaker on the AC side of the inverter. Select a suitable AC circuit breaker according to local regulations.
- When the inverter is powered on, the BACK-UP AC port is live. If maintenance is required on the BACK-UP Loads, please power off the inverter; otherwise, it may cause electric shock.
- For cables used in the same system, it is recommended that the following cable conductor material, cross-sectional area, length, etc., be consistent.
 - Inverter's BACK-UP AC cable
 - Inverter's GRID AC cable
- The inverter supports connecting to a generator via an ATS switch to achieve switching between grid and generator power supply. The ATS switch is by default connected to the grid.

5.3.1 Preparing Breakers

No.	breaker	Recommended Specifications	Acquisition Method	Remarks
1	GRID breaker BACK-UP breaker	<p>For partial backup power scenarios, the recommendations are as follows:</p> <ul style="list-style-type: none"> • Nominal Voltage $\geq 230V_{ac}$ • Nominal current requirements are as follows: <ul style="list-style-type: none"> ◦ GW5K-ETA-G20: 20A ◦ GW6K-ETA-G20: 20A ◦ GW8K-ETA-G20: 20A 	Self-provided	In actual selection, you can also choose a breaker that meets local installation regulations based on the actual working current.

No.	breaker	Recommended Specifications	Acquisition Method	Remarks
		<ul style="list-style-type: none"> ◦ GW9.999K-ETA-G20: 32A ◦ GW10K-ETA-G20: 32A ◦ GW12K-ETA-G20: 40A ◦ GW15K-ETA-G20: 50A ◦ GW20K-ETA-G20: 50A ◦ GW25K-ETA-G20: 63A ◦ GW29.999K-ETA-G20: 80A ◦ GW30K-ETA-G20: 80A <p>For whole-house backup power scenarios, the recommendations are as follows:</p> <ul style="list-style-type: none"> • Nominal Voltage $\geq 230V_{ac}$ • Nominal current requirements are as follows: <ul style="list-style-type: none"> ◦ GW5K-ETA-G20: 63A ◦ GW6K-ETA-G20: 63A ◦ GW8K-ETA-G20: 63A ◦ GW9.999K-ETA-G20: 80A ◦ GW10K-ETA-G20: 80A ◦ GW12K-ETA-G20: 80A ◦ GW15K-ETA-G20: 100A ◦ GW20K-ETA-G20: 100A ◦ GW25K-ETA-G20: 125A ◦ GW29.999K-ETA-G20: 125A ◦ GW30K-ETA-G20: 125A <p>Note: If the inverter BACK-UP</p>		

No.	breaker	Recommended Specifications	Acquisition Method	Remarks
		port is not used, the GRID breaker can be selected based on the maximum grid-connected current.		
2	ATS switch	The specifications of the ATS switch and GRID breaker for the same model are consistent.	Self-provided	
3	RCD	RCD device installation and RCD specification selection: It is recommended to connect a Type A RCD with a residual current trip level $\geq 300\text{mA}$ to the AC output side of the inverter (for inverter capacity $< 30\text{kVA}$, select the residual current action level as 300mA ; for inverter capacity $\geq 30\text{kVA}$, select the residual current action level as 10mA/kVA). Alternatively, select an appropriate RCD specification based on local regulatory requirements.	Self-provided	-

No.	breaker	Recommended Specifications	Acquisition Method	Remarks
4	(Optional) Manual transfer switch	<p>Nominal Voltage $\geq 230\text{Vac}$ Nominal current requirements are as follows:</p> <ul style="list-style-type: none"> GW5K-ETA-G20, GW6K-ETA-G20, GW8K-ETA-G20, GW9.999K-ETA-G20, GW10K-ETA-G20, GW12K-ETA-G20, GW15K-ETA-G20, GW20K-ETA-G20: 63A GW25K-ETA-G20, W29.999K-ETA-G20, GW30K-ETA-G20, GW25K-BTA-G20: 80A 	<ul style="list-style-type: none"> Self-provided Shipped with the inverter (Australia only) 	In actual selection, you can also choose an appropriate manual transfer switch based on local regulations.

5.3.2 Preparing Cables

No.	Cable	Recommended Specification	Source
1	Inverter Chassis Protective Ground Cable	<ul style="list-style-type: none"> Single-core outdoor copper cable Conductor cross-sectional area: <ul style="list-style-type: none"> GW5K-ETA-G20, GW6K-ETA-G20, GW8K-ETA-G20: $4\text{-}6\text{mm}^2$ GW9.999K-ETA-G20, GW10K-ETA-G20, GW12K-ETA-G20, GW15K-ETA-G20, GW20K-ETA-G20: $6\text{-}10\text{mm}^2$ GW25K-ETA-G20, GW29.999K-ETA-G20, GW30K-ETA-G20, GW25K-BTA-G20: $10\text{-}16\text{mm}^2$ 	User-provided

No.	Cable	Recommended Specification	Source
2	PV DC Cable	<ul style="list-style-type: none"> • Industry-standard outdoor photovoltaic cable • Conductor cross-sectional area: 4mm²-6mm² • Cable outer diameter: 5.9mm-8.8mm 	User-provided
3	AC Cable	<ul style="list-style-type: none"> • Inverter AC input/output cable (BACK UP/GRID): • Conductor cross-sectional area: <ul style="list-style-type: none"> ◦ GW5K-ETA-G20, GW6K-ETA-G20, GW8K-ETA-G20: 4-6mm² ◦ GW9.999K-ETA-G20, GW10K-ETA-G20, GW12K-ETA-G20: 6-10mm² ◦ GW15K-ETA-G20, GW20K-ETA-G20: 10-16mm² ◦ GW25K-ETA-G20, GW29.999K-ETA-G20, GW30K-ETA-G20: 16-25mm² • Multi-core outdoor copper cable outer diameter: <ul style="list-style-type: none"> ◦ GW5K-ETA-G20, GW6K-ETA-G20, GW8K-ETA-G20, GW9.999K-ETA-G20, GW10K-ETA-G20, GW12K-ETA-G20: 10-26mm ◦ GW15K-ETA-G20, GW20K-ETA-G20: 18-30mm 	User-provided
4	Smart Meter Power Cable	<ul style="list-style-type: none"> • Outdoor copper cable • Conductor cross-sectional area: 1mm² 	User-provided
5	Meter RS485 Communication cable	<ul style="list-style-type: none"> • Shielded twisted pair • Conductor cross-sectional area: 0.2mm²-0.4mm² 	User-provided

No.	Cable	Recommended Specification	Source
6	EMS or Charging Pile RS485 Communication cable		
7	Remote Shutdown		
8	Load Control and Generator Control DO Communication cable	<ul style="list-style-type: none"> • Shielded cable meeting local standards • Conductor cross-sectional area: 0.2mm²-0.4mm² • Cable outer diameter: 5mm-8mm 	User-provided
9	RCR/DRED/14a Signal Cable		
10	CT Communication cable	standard network cable: CAT 5E or above standard shielded network cable and RJ45 connector	User-provided

5.4 Connecting the PE cable

WARNING

- The protective grounding of the chassis cannot replace the protective ground wire of the AC output port. When wiring, ensure the protective ground wires at both locations are reliably connected.
- To improve the corrosion resistance of the terminal, it is recommended to apply silicone or paint over the external part of the grounding terminal for protection after the protective ground wire connection installation is completed.
- When installing the equipment, the protective ground wire must be installed first; when removing the equipment, the protective ground wire must be removed last.
- The battery grounding is integrated into the blind-mating connector connected to the inverter. The system is uniformly grounded through the inverter, so no separate grounding operation is required for the battery during installation. If there is a requirement for split expansion, please separately ground the expansion battery pack.

Energy storage system grounding:

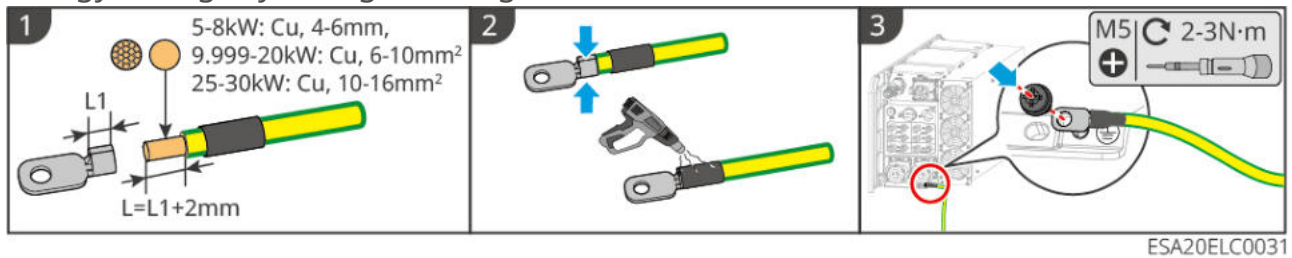

Expansion battery pack grounding:

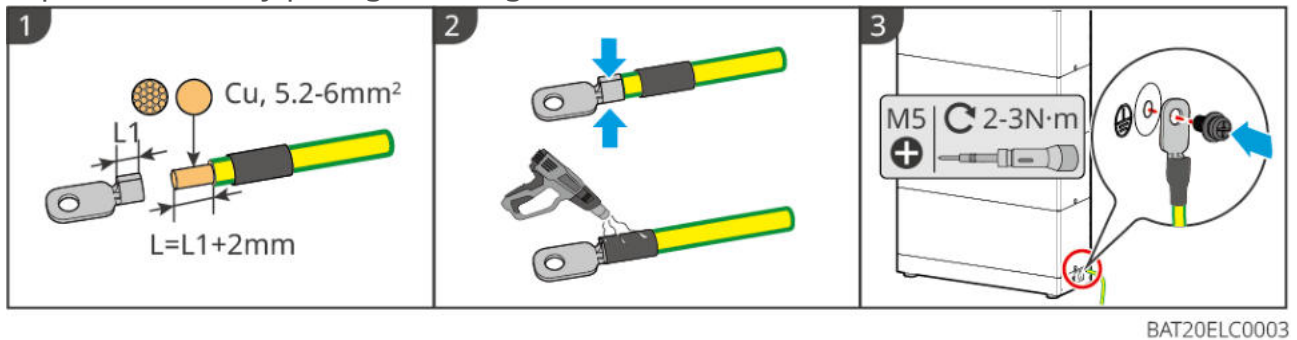

5.5 Connecting the PV Cable

⚠ DANGER

- Do not connect the same PV string to multiple inverters, as this may cause inverter damage.
- Before connecting the PV string to the inverter, confirm the following information. Failure to do so may cause permanent damage to the inverter, and in severe cases, may lead to fire causing personal injury and property damage.
 1. Ensure the maximum short-circuit current and Max. Input Voltage for each MPPT are within the inverter's allowable range.
 2. Ensure the positive pole of the PV string is connected to the inverter's PV+, and the negative pole of the PV string is connected to the inverter's PV-.

⚠ WARNING

- PV string output does not support grounding. Before connecting the PV string to the inverter, ensure the minimum insulation resistance to ground of the PV string meets the minimum insulation resistance requirement ($R = \text{Max. Input Voltage} / 30\text{mA}$).
- After completing the DC cable connection, ensure the cable connections are tight and secure, with no looseness.
- Use a multimeter to measure the positive and negative poles of the DC cables to ensure correct polarity (no reverse connection) and that the voltage is within the allowable range.

NOTICE

- The two PV strings within each MPPT must use the same model, the same number of panels, and the same tilt and azimuth angles to ensure maximum efficiency.

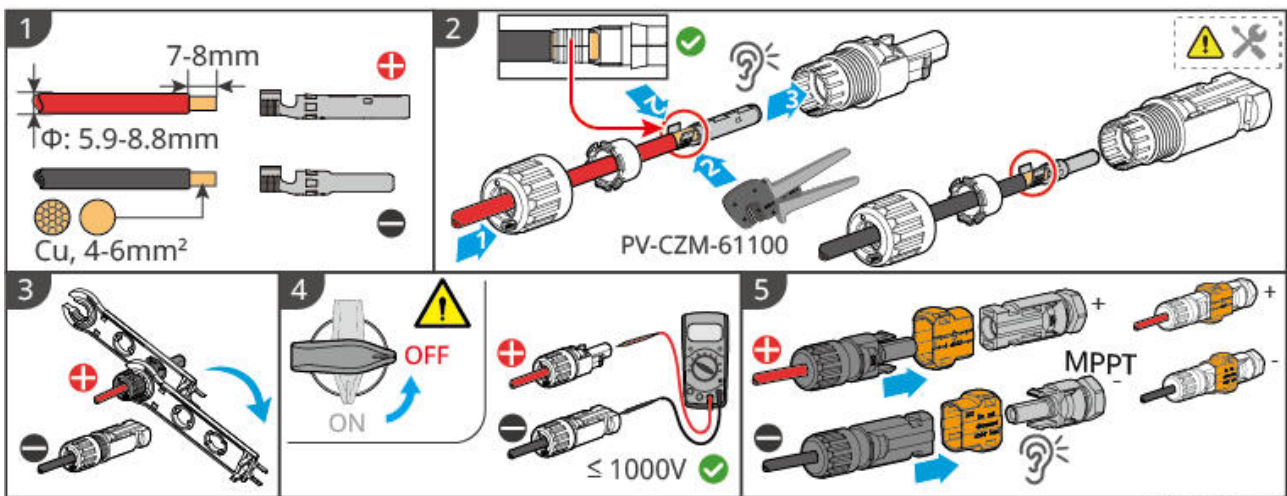

ESA20ELC0030

To disassemble the PV terminal, please refer to the following steps:

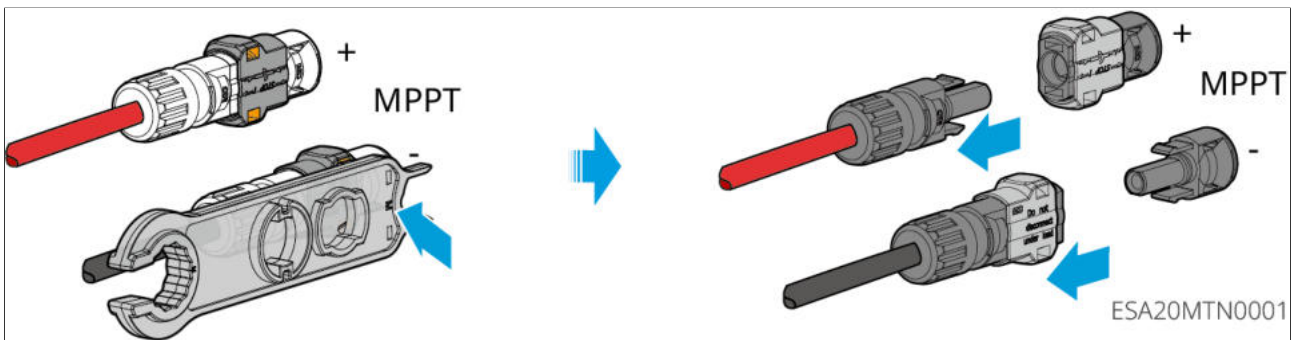

5.6 Connecting the Battery Expansion Cable



- Do not connect loads between the inverter and the battery.
- When connecting battery cables, use insulated tools to prevent accidental electric shock or battery short circuit.
- Ensure the battery open-circuit voltage is within the inverter's allowable range.
- Select whether to configure a DC switch between batteries according to local laws and regulations.
- Do not route wires on the surface or surrounding area of the inverter heat sink to prevent overheating damage to the wiring harness.

Energy Storage System Expansion Overview

A1: Base shipped with the inverter

A2: Installation base with parallel port

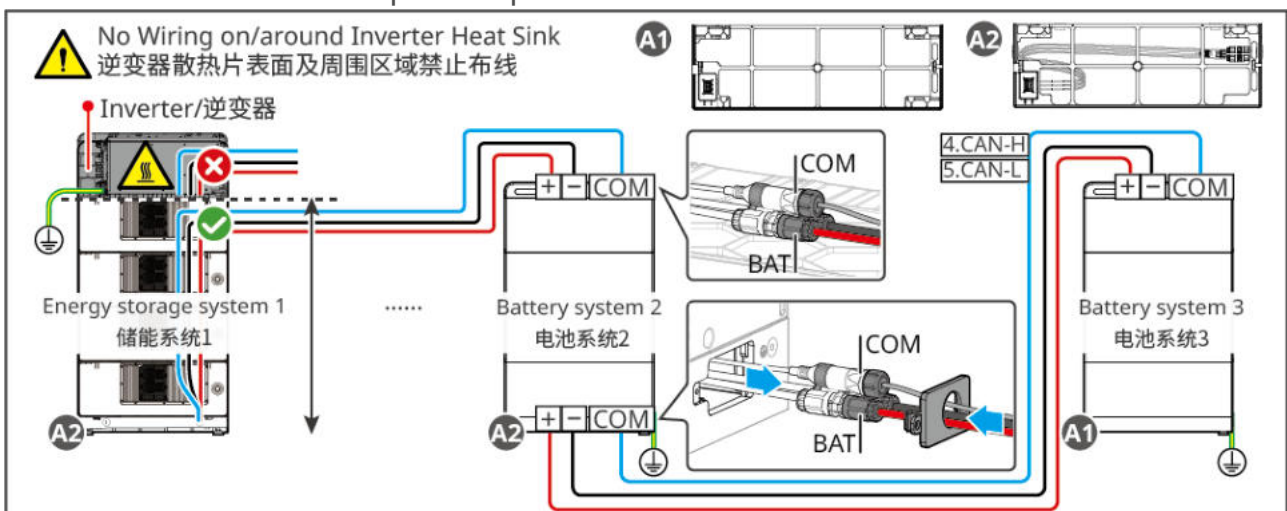

Battery System Expansion Cable Harness Manufacturing Method

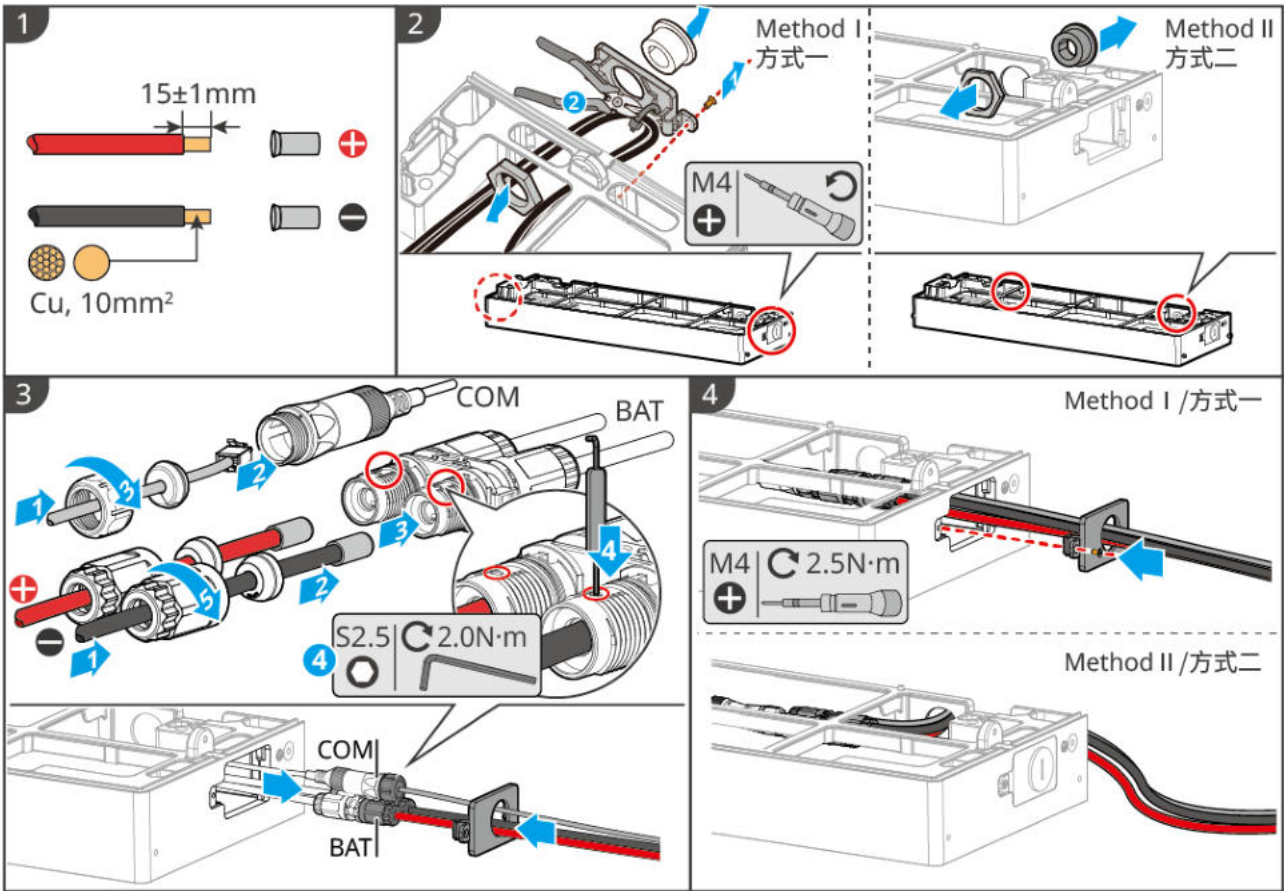

BAT20ELC0004

5.7 Connecting the AC Cable

 WARNING

- The inverter integrates a Residual Current Monitoring Unit (RCMU) internally to prevent residual current from exceeding the specified value. When the inverter detects a leakage current greater than the allowable value, it will quickly disconnect from the grid.
- During wiring, ensure the AC cables fully match the "BACKUP" and "GRID" ground ports of the AC terminals. Incorrect cable connection will cause equipment damage.
- Ensure the wire cores are fully inserted into the terminal wiring holes with no exposed parts.
- Ensure the insulation plate at the AC terminals is securely fastened and not loose.
- Ensure the cable connections are tight. Otherwise, during operation, overheating of the terminals may occur, leading to equipment damage.

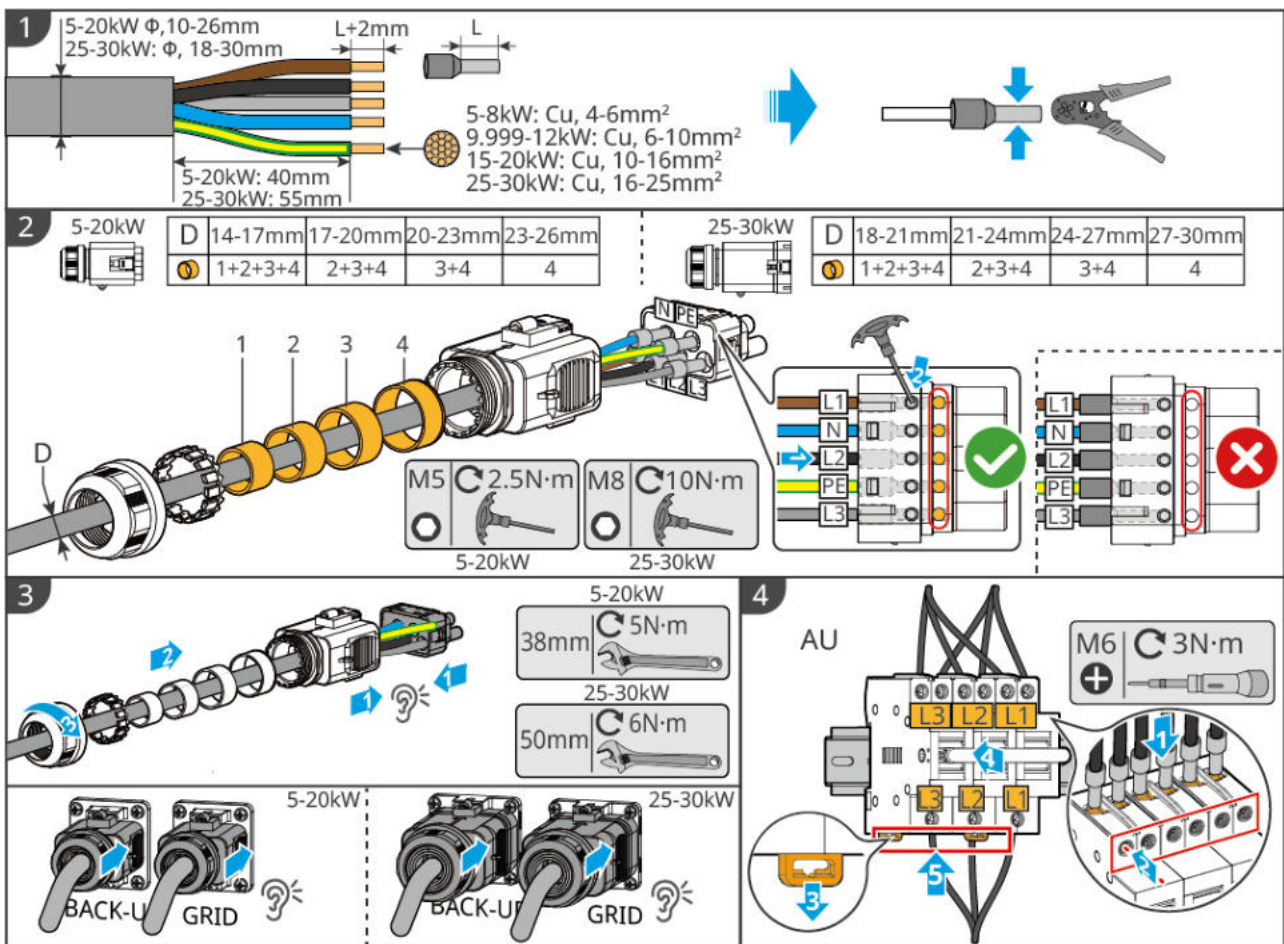

ESA20ELC0027

If you need to disassemble the AC terminal, please refer to the following steps:

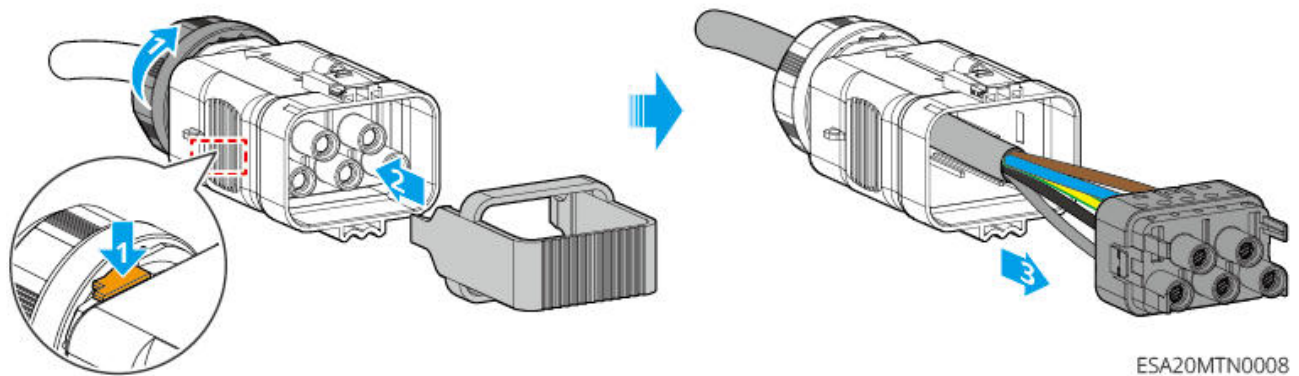
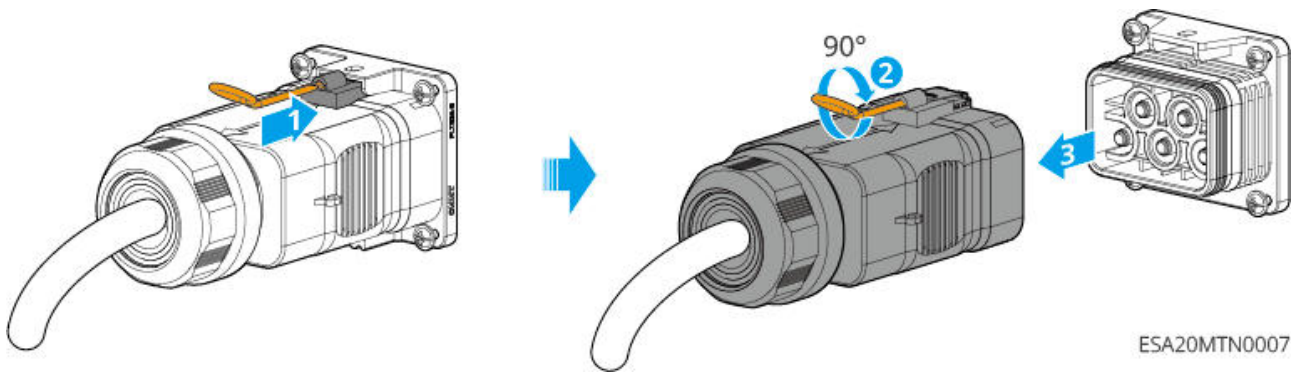

5.8 Connecting the Meter Cable

NOTICE

- If there is a need for multiple inverters to be connected in parallel for networking, please consult the manufacturer to purchase a meter separately.
- Please ensure that the CT connection direction and phase sequence are correct; otherwise, it may lead to incorrect monitoring data.
- Ensure that all cables are connected correctly, tightly, and without looseness. Improper wiring may cause poor contact or damage to the meter.
- In areas with lightning risks, if the meter cable length exceeds 10m and the cables are not laid with grounded metal conduits, it is recommended to install external lightning protection devices.

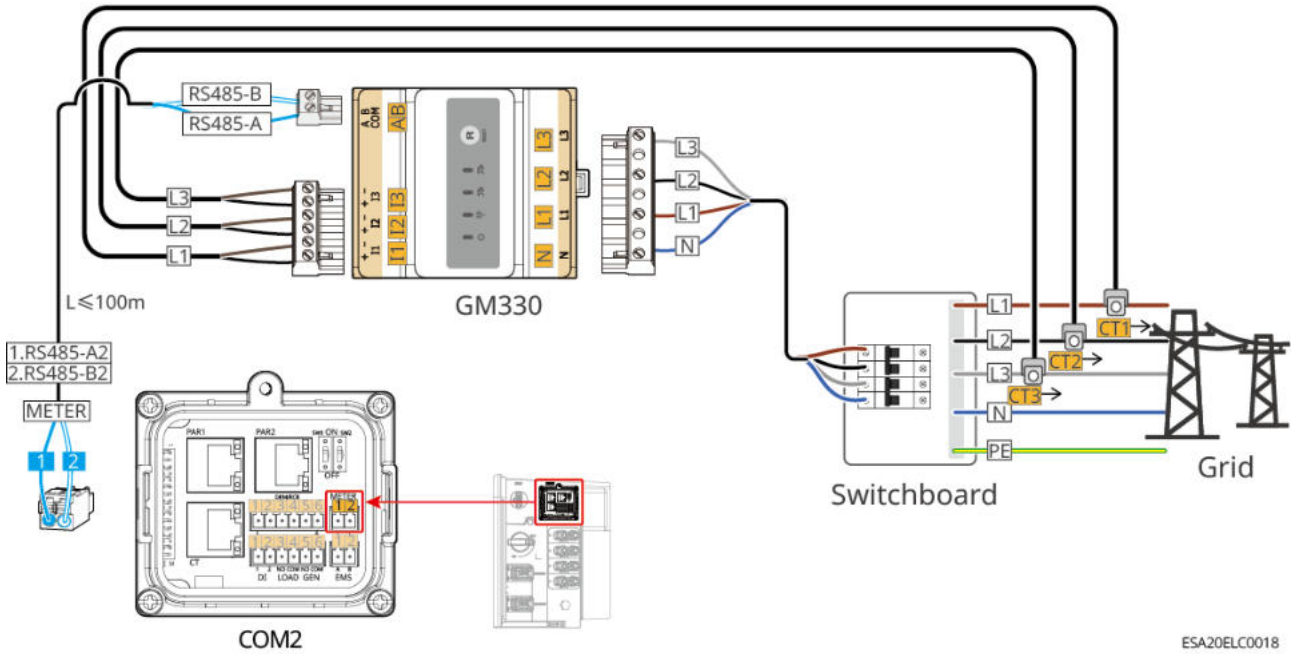

ESA20ELC0018

GMK330 Meter Wiring

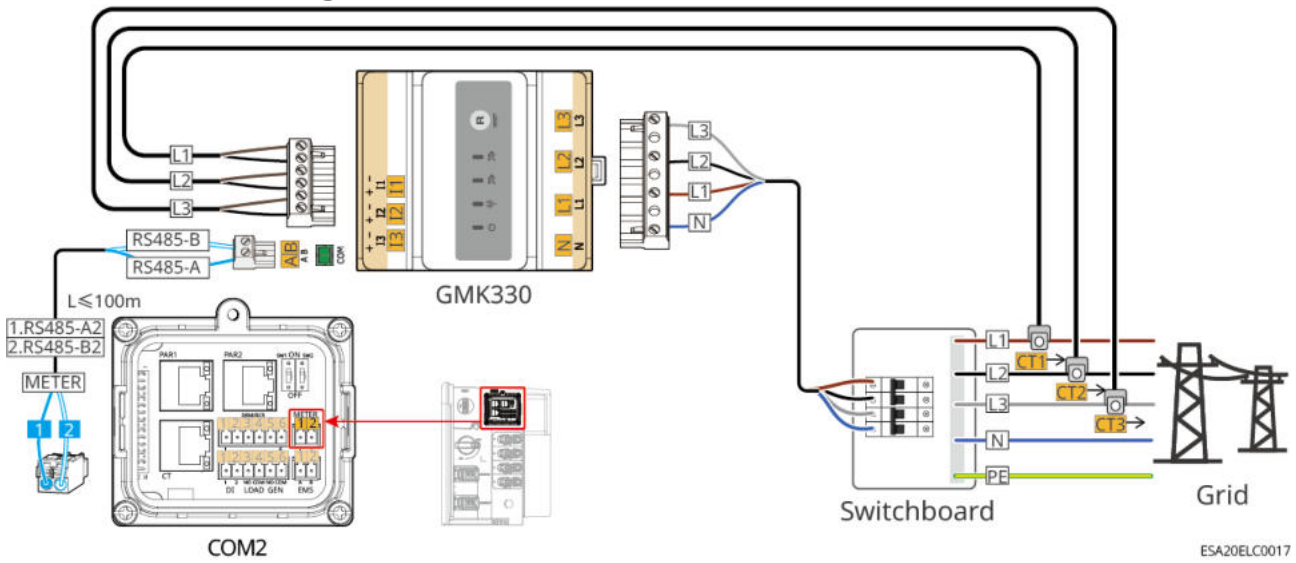

ESA20ELC0017

Wiring Steps

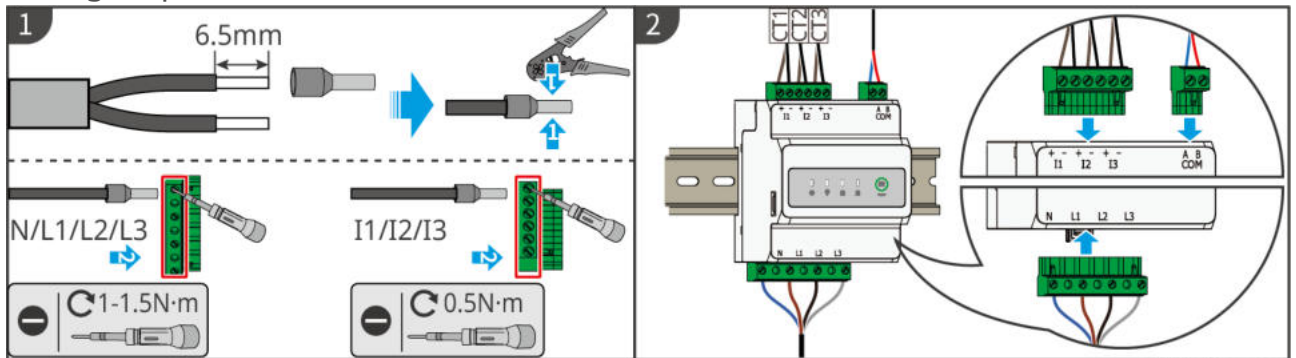

GMK10ELC0004

Install CT (Type One)

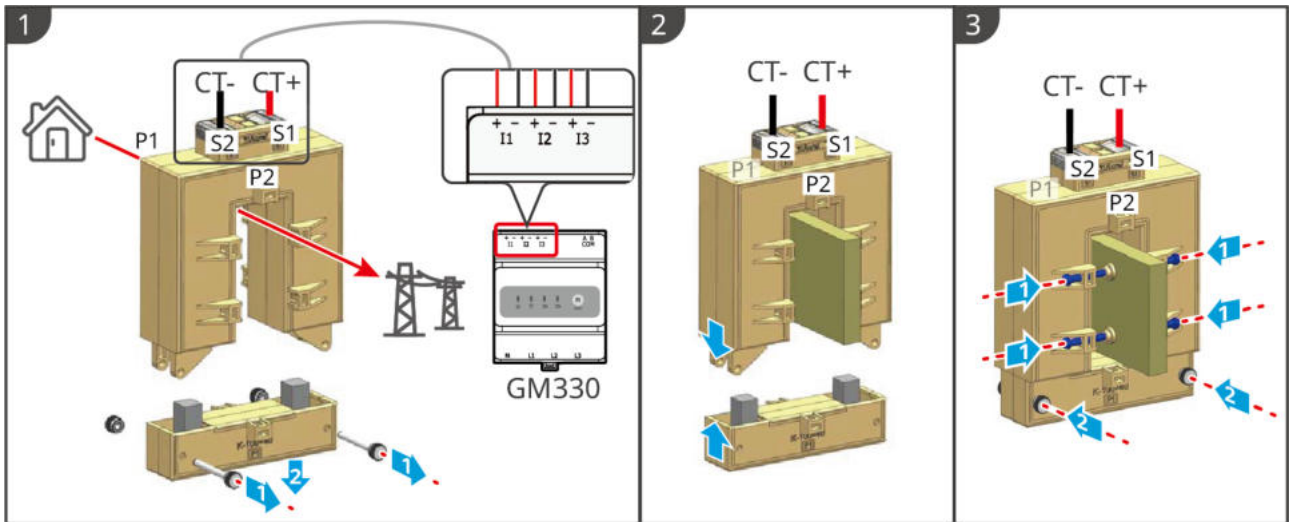

GMK10ELC0006

Install CT (Type Two)

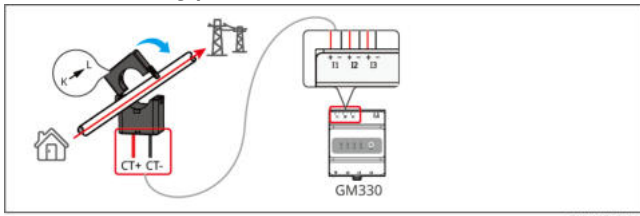

GMK10ELC0007

5.9 Connecting the Inverter Communication Cable

NOTICE

- To ensure the meter and CT function properly, please ensure the following: the CT must be correctly matched and connected to the phase line—CT1 to L1, CT2 to L2, and CT3 to L3.
- When using the Inverter's built-in meter, please use the CT shipped with the unit.
- If you need to use the DRED, RCR, or remote shutdown function, please enable it in the SEMS+ App after wiring is completed.
- Do not enable this function in the SEMS+ App if the Inverter is not connected to a DRED device or remote shutdown device, otherwise the Inverter will not be able to operate on-grid.
- To maintain the Inverter's waterproof rating, do not remove the waterproof plugs from any unused communication ports on the Inverter.
- The Inverter's DO signal communication port can connect to a dry contact signal with the following specifications: Max \leq 24Vdc, 1A.
- The Inverter's communication functions are optional; please select according to the actual usage scenario.
- The Inverter supports connecting via Bluetooth, WiFi, or LAN to a mobile phone or WEB interface to set device parameters, view device operation information and error messages, and stay informed about system status.

Communication Function Description

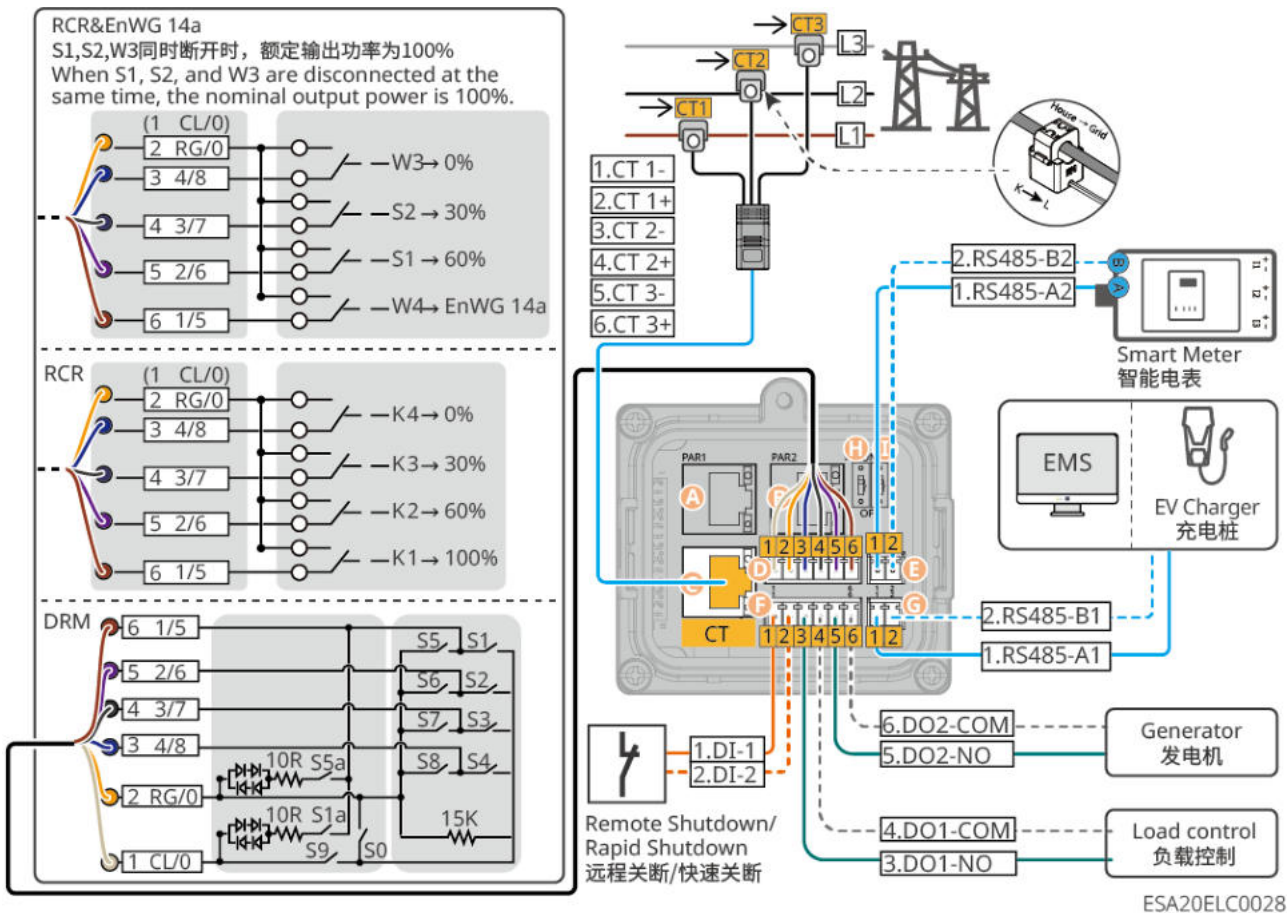

Port (Silkscreen)	Function	Description	
A	PAR1	Reserved	
B	PAR2		
C	CT	CT Connection Port	Only when using the inverter's built-in meter, it is necessary to connect the CT communication cable.

Port (Silkscreen)		Function	Description
D	DRM/RCR	RCR, DRED or EnWG 14a Function Connection Port	<ul style="list-style-type: none"> • RCR (Ripple Control Receiver): Provides RCR signal control port to meet the grid dispatch requirements in European regions. • DRED (Demand Response Enabling Device): Provides DRED signal control port to meet the DERD certification requirements in regions like Australia. • EnWG (Energy Industry Act) 14a: All controllable loads need to accept emergency dimming from the grid. Grid operators can temporarily reduce the maximum grid purchase power of controllable loads to 4.2kW.
E	METER	Meter Connection Port	Use RS485 communication to connect to an external smart meter.
F	DI	Remote Shutdown / Rapid Shutdown	<ul style="list-style-type: none"> • External Remote Shutdown device, default is off. • In a Rapid Shutdown system, the Rapid Shutdown transmitter and receiver are used together to achieve rapid system shutdown. The receiver maintains component output by receiving signals from the transmitter. The transmitter can be external or built into the inverter. In case of an emergency, by enabling an external trigger device, the transmitter can be stopped, thereby shutting down the components.

Port (Silkscreen)		Function	Description
	LOAD	load control	<ul style="list-style-type: none"> • Supports connection to dry contact signals to achieve functions such as load control. The DO contact capacity is 24V DC@1A, NO/COM normally open contacts. • Supports SG Ready heat pump access, controlling the heat pump via dry contact signals.
	GEN	Generator Control Port	Supports connecting generator control signals to control generator start/stop. In microgrid scenarios, connecting a generator is not supported.
G	EMS	EMS/Charging Pile Communication Port	Connect to third-party EMS devices for energy control or connect to GoodWe charging piles.
H	SW1	-	-
I	SW2	-	-

Method for Connecting the Communication Cable

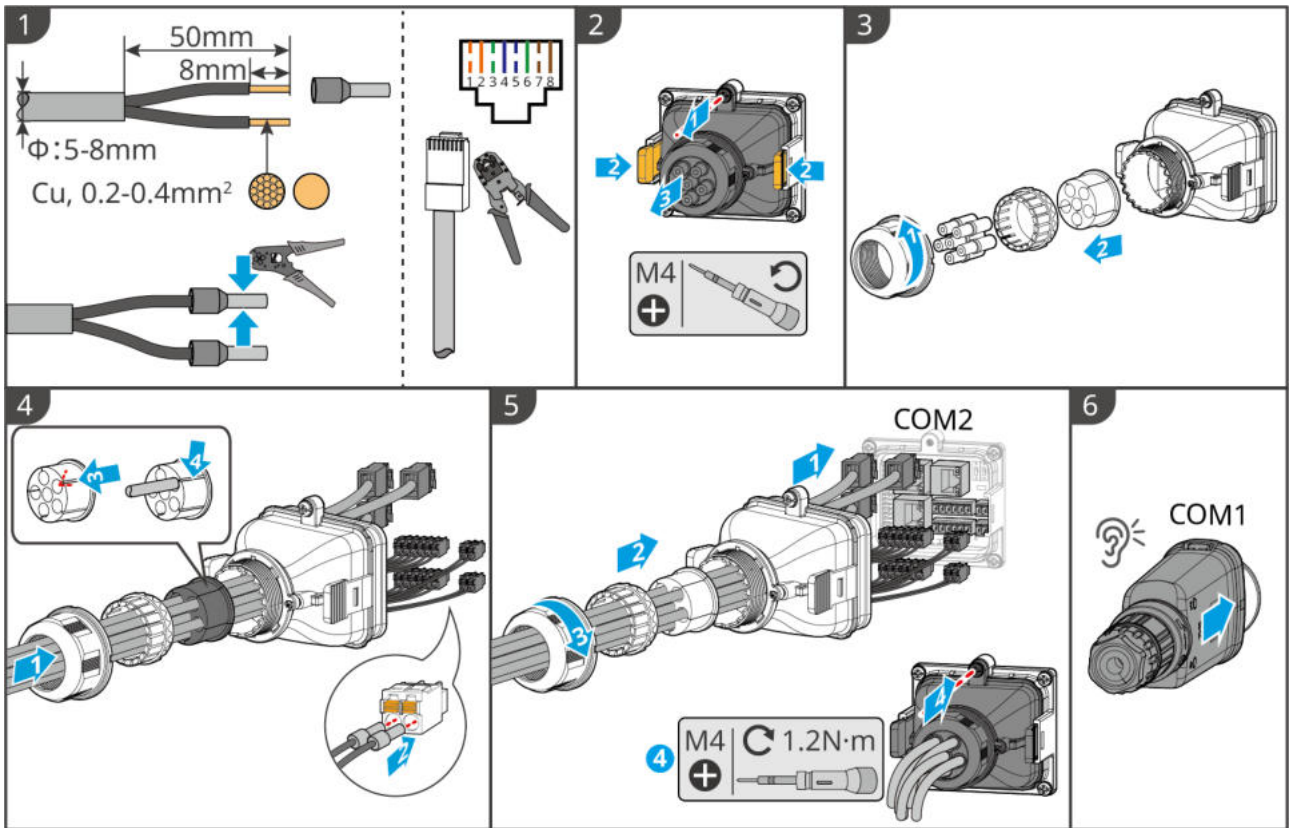

ESA20ELC0005

6 System Commissioning

6.1 Check Before Power ON

No.	Check Item
1	The equipment is securely installed, the installation location facilitates operation and maintenance, the installation space allows for ventilation and heat dissipation, and the installation environment is clean and tidy.
2	The PE cable, DC cable, AC cable, and communication cable are connected correctly and securely.
3	Cable bundling meets wiring requirements, is reasonably distributed, and shows no damage.
4	For unused cable entry holes and ports, please use the terminals provided with the accessories for reliable connection, and ensure they are sealed.
5	Ensure that all used cable entry holes have been sealed.
6	The voltage and frequency at the inverter grid connection point meet the grid interconnection requirements.

6.2 Power ON

WARNING

- Battery black start: When there is no PV power generation in the photovoltaic system and the grid is abnormal, if the inverter cannot work normally, the battery black start function can be used to force battery discharge to start the inverter. The inverter can enter off-grid mode operation, and the battery supplies power to the load.
- After the battery system is started, please ensure that the communication between the inverter and the battery system is normal within 15 minutes. If the inverter and the battery system cannot communicate normally, the battery system switch will automatically disconnect, cutting off power to the battery system.
- When the inverter is working normally, set the manual transfer switch to position B, and the load is powered by the inverter's BACK-UP port. When the inverter is powered down for maintenance or in case of a fault, to ensure normal operation of the load, please set the manual transfer switch to position A, and the load is powered by the grid.

NOTICE

When the system is powered on for the first time, it is recommended to perform a battery black start. Close the battery power switch and briefly press the multifunction button on one of the batteries. Observe whether the inverter SOC indicator lights up. If the indicator lights up, it indicates the battery is connected properly, and you can proceed to close the DC switch of the inverter.

power on

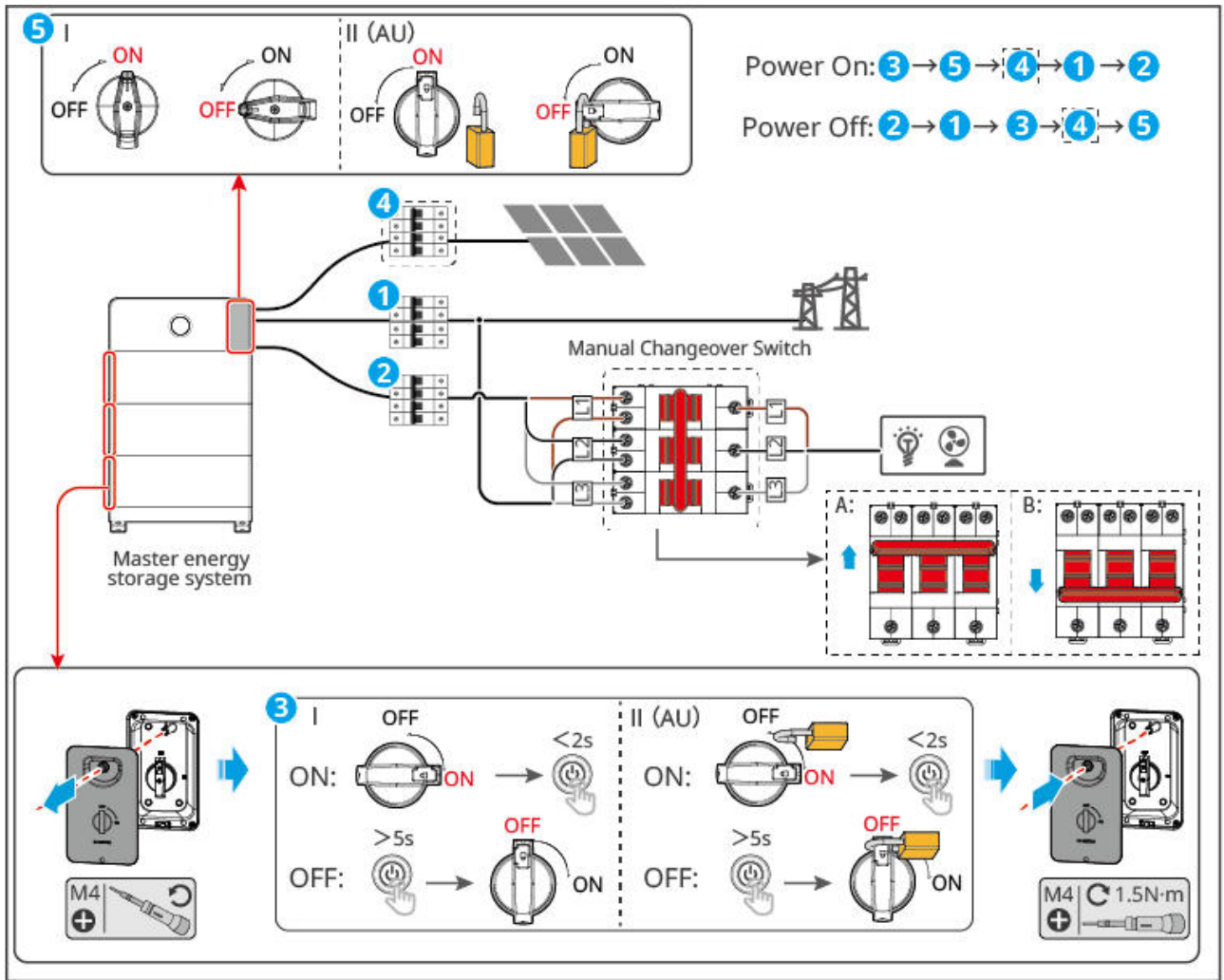

ESA20PWR0003

1. Close the battery power switch and briefly press the multifunction button on the battery. If there are multiple batteries in the system, close the power switch on all batteries. Briefly pressing the multifunction button on any one battery will start all batteries.
2. Close the DC switch of the inverter.
3. (Optional) Close the circuit breaker between the PV module and the inverter.
4. Close the GRID circuit breaker.
5. Close the BACK-UP circuit breaker, and (optional) manually switch the transfer switch to state B.

Battery Black Start

1. Close the battery power switch. If there are multiple batteries in the system, close the power switch on all batteries.

2. Close the DC switch of the inverter.
3. (Optional) Close the circuit breaker between the PV module and the inverter.
4. Close the GRID circuit breaker.
5. Close the BACK-UP circuit breaker.
6. After all batteries are powered on separately, wait for 15 seconds, then press and hold the multifunction button on any battery for 2 seconds to force the battery to discharge and activate the inverter.

6.3 Install Protective Cover

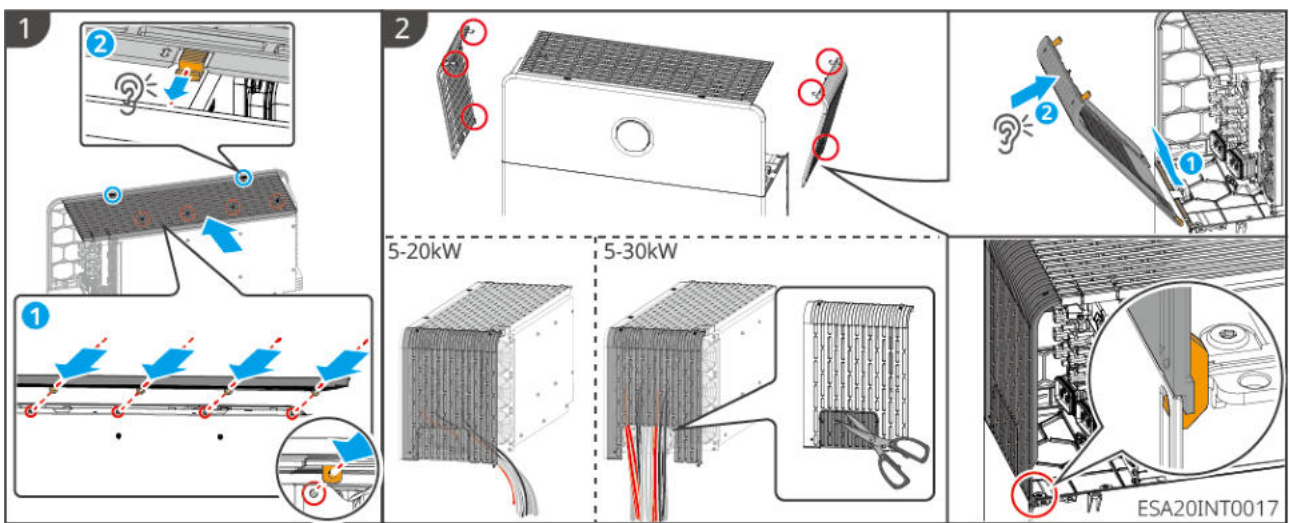





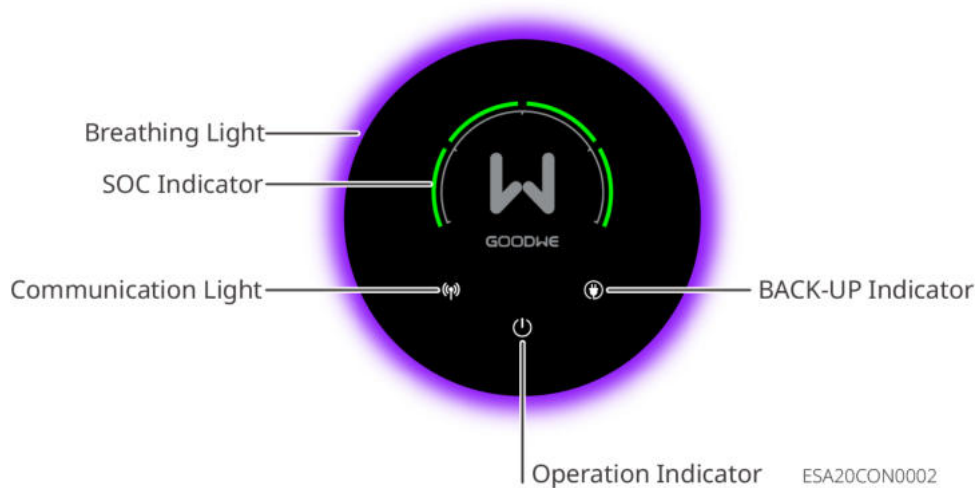



6.4 Indicators

6.4.1 Inverter Indicators



Breathing Light:

- When the system is upgrading: The breathing light is a green running light; the head of the running light is the brightest and the tail is the dimmest, the length of the running light and the upgrade percentage are affected by the SEMS+ App settings and the device's operational status.
- Except for inverter upgrade, system fault, and inverter power-off status, the breathing light status is affected by the App settings on the SEMS+ App. For setup instructions, please refer to the SEMS+ App User Manual.

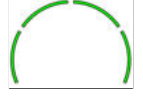

indicator	Indicator Status	Breathing Light Status	Description
		<ul style="list-style-type: none"> • 3min/Always on: Blue-purple chasing light stays on 	The inverter is powered on and in standby mode
		<ul style="list-style-type: none"> • Always off: Not lit 	The inverter is starting up and in self-test mode
		<ul style="list-style-type: none"> • 3min: Blue-purple breathing for 3min then off • Always on in App: Blue-purple breathing stays on • Always off in App: Not lit 	The inverter is operating normally in grid-tied power generation or off-grid mode
		Red flashing	System fault
		Off	The inverter is powered off
		/	Inverter monitoring module is resetting
			Inverter and communication terminal are not connected

indicator	Indicator Status	Breathing Light Status	Description
			Communication failure between communication terminal and cloud server
			Inverter monitoring is normal
			Inverter monitoring module is not started
			Grid abnormal, inverter BACK-UP port power supply normal
			Grid normal, inverter BACK-UP port power supply normal
			BACK-UP port has no power supply
			System upgrade
			System fault
			Battery has no charge
			Constantly lit: Charge Flashing: Discharge Battery SOC: $0\% < SOC \leq 25\%$
			Constantly lit: Charge Flashing: Discharge Battery SOC: $25\% < SOC \leq 50\%$

indicator	Indicator Status	Breathing Light Status	Description
			Constantly lit: Charge Flashing: Discharge Battery SOC: $50\% < SOC \leq 75\%$
			Constantly lit: Charge Flashing: Discharge Battery SOC: $75\% < SOC \leq 100\%$





6.4.2 Battery Indicators

Button Indicator Light

No.	 Green Light	 Red Light	Battery System Status	Description
1	Steady On	--	System operating normally	Run
2	Blinking1 time/S	--	System ready	Standby
	Blinking3 times/S	--	PCS communication lost	--
3	Blinking1 time/2S	--	System alarm	Includes Level 2 faults from the fault list, where under-voltage fault is at Level 2, 3, or 4
4	--	Steady On	System fault	Level 3 and above faults in the fault list (steady on when under-voltage fault is Level 5)

6.4.3 Smart Meter Indicator Lights GM330&GMK330

6.4.3.1 Indicator Light Description











Type	Status	Description
 Power Light	Steady On	The meter is powered on, with no RS485 communication.
	Blinking	The meter is powered on, with normal RS485 communication.
	Off	The meter is powered off.
 Comm Light	Off	Reserved.
	Blinking	Press and hold the Reset button for $\geq 5s$, and the Power Light and Buy/Sell Power Light blink: The meter is resetting.
 Buy/Sell Power Light	Steady On	buy power from the grid.
	Blinking	Selling power to the grid.
	Off	Not buying or selling power.
 Buy/Sell Power Light (GMK360 only)	Steady On	buy power from the grid.
	Blinking	Selling power to the grid.
	Off	Not buying or selling power.

6.4.4 Smart Dongle Indicator

- WiFi/LAN Kit-20

NOTICE

- After double-clicking the Reload button to turn on Bluetooth, the communication indicator light will switch to a single-blink state. Please connect to the SEMS + App within 5 minutes, otherwise Bluetooth will automatically turn off.
- The communication indicator light's single-blink state only appears after double-clicking the Reload button to turn on Bluetooth.

Indicator	Status	Description
Power indicator 		Steady on: The Smart Communication Stick is powered on.
		Off: The Smart Communication Stick is not powered on.
Communication indicator 		Steady on: Communication is normal in WiFi mode or LAN mode.
		Single blink: The Smart Communication Stick's Bluetooth signal is enabled, waiting to connect to the SEMS + App.
		Two blinks: The Smart Communication Stick has not connected to the router.
		Four blinks: The Smart Communication Stick communicates normally with the router but has not connected to the server.
		Six blinks: The Smart Communication Stick is identifying connected devices.
		Off: The Smart Communication Stick is undergoing a software reset or is not powered on.

Indicator	Color	Status	Description
	Green	Steady on	100Mbps wired network connection is normal.

Indicator	Color	Status	Description
LAN port communication indicator 	Yellow	Off	<ul style="list-style-type: none"> • Network cable is not connected. • 100Mbps wired network connection is abnormal. • 10Mbps wired network connection is normal.
		Steady on	10/100Mbps wired network connection is normal, with no communication data being transmitted or received.
		Flashing	Communication data is being transmitted or received.
		Off	Network cable is not connected.

Button	Description
Reload	Hold for 0.5 to 3 seconds to reset the Smart Communication Stick.
	Hold for 6 to 20 seconds to restore the Smart Communication Stick to factory settings.
	Double-click quickly to enable Bluetooth signal (maintained for only 5 minutes).

7 System Commissioning

7.1 Setting Inverter Parameters via App

SEMS + App is a software used for remote power station monitoring or local device debugging. It supports installers or owners:

- Remotely monitor the operation of power stations and set parameters for stations and equipment.
- Locally connect to devices, view device operation status, and set device parameters.

For detailed functions, please refer to the "[SEMS + App User Manual](#)".

The user manual can be obtained from the official website or by scanning the QR code below.



SEMS+ App User Manual

7.1.1 Download and Install SEMS + App

Phone Requirements:

- Operating System: Android 7.0 or above, iOS 15.1 or above.
- Phone must support a web browser and connect to the Internet.
- Phone must support WLAN/Bluetooth functionality.

Download Methods:

Method 1:

Search for "SEMS +" in Google Play, App Store, Huawei, Honor, Xiaomi, OPPO, or vivo app stores to download and install.



Method 2:

Scan the QR code below to download and install.



7.2 Power Plant Monitoring via SEM+ WEB

SEM+ WEB is a monitoring platform that communicates via WiFi or LAN. The following are the common functions of SEM+ WEB:

1. Manage organization or user information, etc.
2. Add and monitor power plant information, etc.
3. Maintain equipment.

For detailed functions, please refer to the [SEM+ WEB User Manual](#).



"SEM+ WEB User Manual"

8 Maintenance

8.1 Power OFF the System

DANGER

- When performing operation and maintenance on devices in the system, please power off the system. Operating devices with power on may cause device damage or electric shock DANGER.
- After the device is powered off, internal components require some time to discharge. Please wait until the device is completely discharged according to the label time requirements.
- Restarting the battery should be done using the air switch power-on method.
- When shutting down the battery system, strictly adhere to the battery system power-off requirements to prevent damage to the battery system.

NOTICE

- To ensure effective protection of the battery system, keep the cover plate of the battery system switch closed. If the battery system switch is not used for an extended period, secure it with screws.

power off

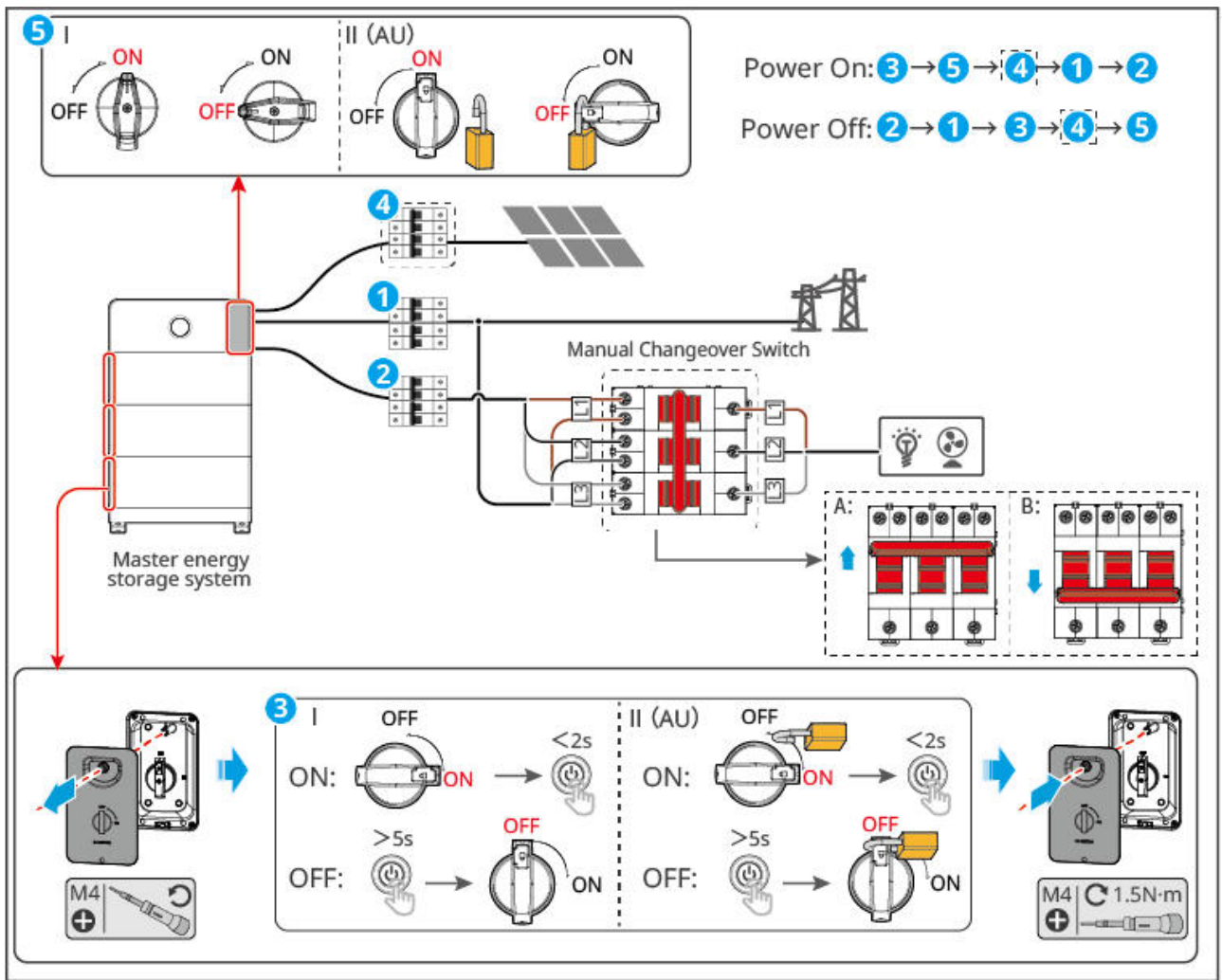

ESA20PWR0003

1. Disconnect the BACK-UP circuit breaker.
2. Disconnect the GRID circuit breaker.
3. Press and hold any battery's multifunction button for 5 seconds to power off the battery system. If the system contains multiple batteries, this operation will power off all batteries; there is no need to operate them individually. Finally, disconnect the battery system switch.
4. (Optional) Disconnect the circuit breaker between the PV components and the inverter.
5. Disconnect the inverter's DC switch. (Optional) Set the manual transfer switch to position A.

8.2 Removing the Equipment

 **DANGER**

- Ensure the device is powered off.
- When operating the device, please wear personal protective equipment.
- When removing wiring terminals, use standard disassembly tools to avoid damaging the terminals or device.
- Unless otherwise specified, the device disassembly method is the reverse order of the installation method, and this document will not elaborate further.

1. Power down the system.
2. Label the cables connected in the system to indicate their types.
3. Disconnect the cables from the Inverter, Battery, and smart meter in the system, such as DC cables, AC cables, Communication cable, and PE cable.
4. Remove equipment such as the smart communication stick, Inverter, Battery, and smart meter.
5. Store the equipment properly. If it will be put into use again later, ensure the storage conditions meet the requirements.

8.3 Disposing of the Equipment

When the equipment can no longer be used and needs to be disposed of, please handle it according to the electrical waste disposal requirements of the regulations in the country/region where the equipment is located. The equipment must not be disposed of as general household waste.

8.4 Routine Maintenance

 **WARNING**

- If any issues that may affect the battery or energy storage inverter system are found, contact after-sales personnel. Disassembly by unauthorized persons is prohibited.
- If exposed copper wires inside the conductive wires are found, do not touch them. High voltage danger. Contact after-sales personnel. Disassembly by unauthorized persons is prohibited.
- In case of other emergencies, contact after-sales personnel immediately. Operate under the guidance of after-sales personnel or wait for on-site operation by after-sales personnel.

Maintenance Item	Maintenance Method	Maintenance Cycle	Maintenance Purpose
System Cleaning	Check the heat sink and air inlet/outlet for foreign objects or dust. Check if the installation space meets requirements and if there is debris accumulation around the equipment.	Once every 6 months	Prevent cooling failures.
System Installation	Check if the equipment installation is secure and if fastening screws are loose. Check the equipment exterior for damage or deformation.	Once every 6 months to once a year	Confirm equipment installation stability.
Electrical Connections	Check electrical connections for looseness, inspect cable exteriors for damage or exposed copper.	Once every 6 months to once a year	Confirm electrical connection reliability.
Fan	Check the fan for abnormal noise; Check fan blades for cracks; Check the fan for abnormal blockage/stalling;	Once every 6 months	Prevent fan failure.

Maintenance Item	Maintenance Method	Maintenance Cycle	Maintenance Purpose
Sealing	Check if the sealing of equipment cable entry holes meets requirements. If gaps are too large or unsealed, reseal them.	Once a year	Confirm machine sealing and waterproof integrity.
Battery Maintenance	If the battery has not been used or fully charged for an extended period, it is recommended to charge it regularly.	Once every 15 days	Protect battery service life.

For fan maintenance, refer to the following steps:

The inverter has a fan module on the outside. To better clean the fan module, please remove it from the machine before cleaning. The specific steps are as follows:

1. Power off the inverter. You can refer to [8.1.Power OFF the System\(Page 125\)](#).
2. Wait for the system residual voltage to be completely discharged and the fan module to completely stop running.
3. Use a screwdriver to remove the module mounting screws and take out the entire fan module.
4. Use a soft brush, cloth, or vacuum cleaner to clean the fan.

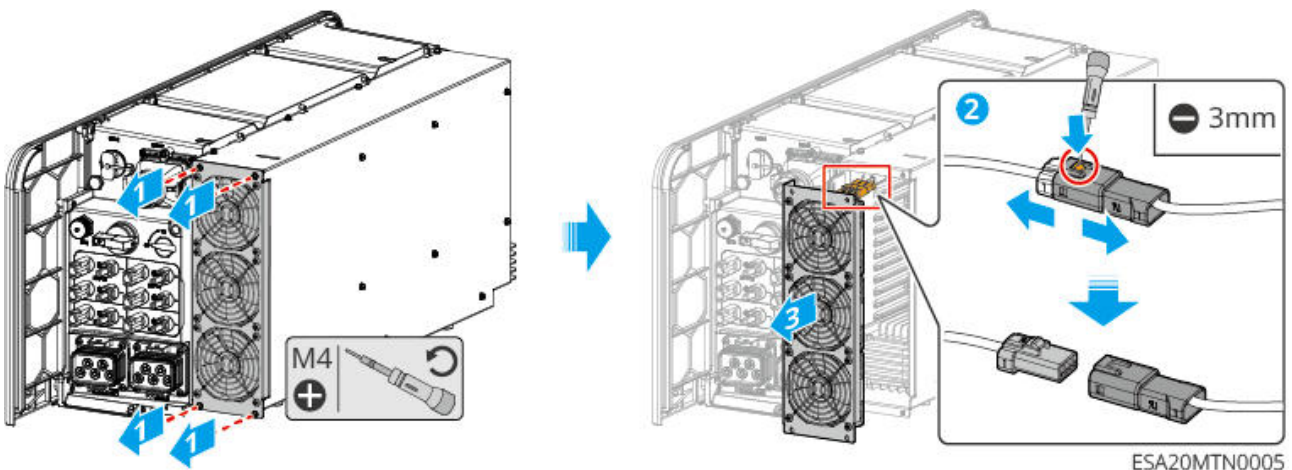

After cleaning is completed, reinstall the fan module back into the machine.

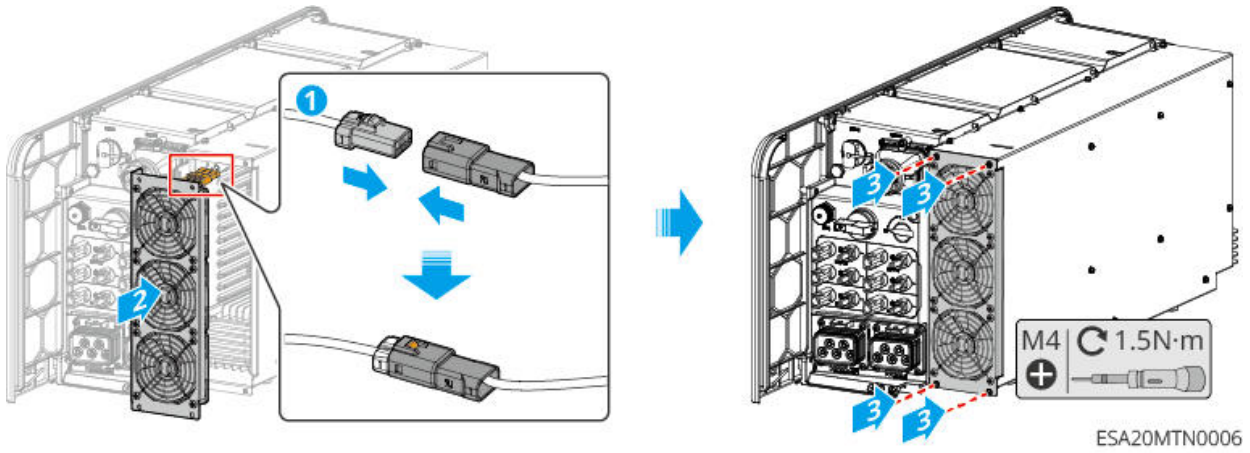

8.5 fault

8.5.1 Viewing Fault/Alarms Information

Detailed information for all faults and alarms in the energy storage system is displayed in the **SEMS+ App and SEMS+ WEB** .

If your product experiences an abnormality and no related fault information is seen in the **SEMS+ App or SEMS+ WEB**, please contact the after-sales service center.

- In SEMS+ App

1. Open the SEMS+ App and log in with any account.
2. On the homepage, click "Alarms" to view alarm information for all power plants under the account.

- SEMS+ WEB

1. Open the SEMS+ WEB and log in with any account.
2. On the power plant details interface, click "Alarms" to view all alarm information for the current power plant.

8.5.2 Fault Information and Troubleshooting

Please perform troubleshooting according to the following methods. If the troubleshooting methods cannot help you, please contact the after-sales service center.

When contacting the after-sales service center, please collect the following information to facilitate a quick resolution.

1. Product information, such as: serial number, software version, device installation time, fault occurrence time, fault frequency, etc.
2. Device installation environment, such as: weather conditions, whether components are blocked, have shadows, etc. It is recommended to provide photos, videos, and

other files to assist in problem analysis.

3. Grid conditions.

If the system experiences a problem not listed, or if following the instructions still cannot prevent the problem or abnormality, immediately stop system operation and contact your dealer immediately.

No.	fault	Resolution
1	Unable to search for the Smart Communication Stick's wireless signal	<ol style="list-style-type: none">1. Ensure no other devices are connected to the Smart Communication Stick's wireless signal.2. Ensure the Smart Communication Stick is powered normally, with the blue signal light flashing or steady on.3. Ensure the smart device is within the communication range of the Smart Communication Stick.4. Refresh the App device list again.5. Restart the inverter.
2	Unable to connect to the Smart Communication Stick's wireless signal	<ol style="list-style-type: none">1. Ensure no other devices are connected to the Smart Communication Stick's wireless signal.2. Restart the inverter or the communication stick, then try connecting to the Smart Communication Stick's wireless signal again.3. Ensure Bluetooth pairing and encryption were successful.
3	Unable to find the router's SSID	<ol style="list-style-type: none">1. Place the router closer to the Smart Communication Stick, or add a WiFi repeater to enhance the WiFi signal.2. Reduce the number of devices connected to the router.

No.	fault	Resolution
4	After all configuration is complete, the Smart Communication Stick fails to connect to the router	<ol style="list-style-type: none"> 1. Restart the inverter. 2. Check if the network name, encryption method, and password in the WiFi configuration match those of the router. 3. Restart the router. 4. Place the router closer to the Smart Communication Stick, or add a WiFi repeater to enhance the WiFi signal.
5	After all configuration is complete, the Smart Communication Stick fails to connect to the server	Restart the router and the inverter.

8.5.2.1 Inverter fault

fault code	fault name	fault cause	Troubleshooting recommendation
F01	Grid Power Outage	<ol style="list-style-type: none"> 1. Utility grid power outage. 2. AC line or AC Switch disconnected. 	<ol style="list-style-type: none"> 1. The alarm automatically disappears after Grid connected recovery. 2. Check if the AC line or AC Switch is disconnected.
F02	Grid Overvoltage Protection	Utility gridvoltage exceeds the allowable range, or the high voltage Duration surpasses the high voltage ride-through setting value.	1. If it occurs occasionally, it may be due to a temporary abnormality in the Utility grid. The Inverter will resume normal operation after detecting that the Utility grid is functioning properly, without requiring

fault code	fault name	fault cause	Troubleshooting recommendation
			<p>manual intervention.</p> <p>2. If it occurs frequently, check whether Utility grid and voltage are within the allowable range.</p> <ul style="list-style-type: none"> • If Utility grid voltage exceeds the permissible range, please contact the local power operator. • If the Utility grid voltage is within the allowable range, it is necessary to modify the InverterGrid Overvoltage Protection point after obtaining consent from the local power operator, HVRTEnable or disable the Grid Overvoltage Protection function. <p>3. If the issue persists for an extended period, please check whether the breaker on the AC side and the output cables are properly connected.</p>

fault code	fault name	fault cause	Troubleshooting recommendation
F03	Grid Undervoltage Protection	Utility gridvoltage is below the allowable range, or the low-voltage Duration exceeds the Low Voltage ride-through setting value.	<p>1. If it occurs occasionally, it may be due to a temporary anomaly in Utility grid. The Inverter will resume normal operation after detecting that Utility grid is functioning properly, without requiring manual intervention.</p> <p>2. If it occurs frequently, check whether the Utility grid and voltage are within the allowable range.</p> <ul style="list-style-type: none"> • If Utility gridvoltage exceeds the permissible range, please contact the local power operator. • If the Utility gridvoltage is within the allowable range, it is necessary to modify the InverterGrid Undervoltage Protection point after obtaining consent from the local power operator.LVRTEnable or disable the Grid Undervoltage Protection function. <p>3. If the issue persists for an extended period,</p>

fault code	fault name	fault cause	Troubleshooting recommendation
			<p>please check whether the AC-side breaker and output cables are properly connected.</p>
F04	Grid Rapid Overvoltage Protection	Utility gridvoltage detection shows abnormality or ultra-high voltage triggers fault.	<p>1. If it occurs occasionally, it may be due to a temporary anomaly in Utility grid. Inverter will resume normal operation after detecting that Utility grid is functioning properly, without requiring manual intervention.</p> <p>2. If it occurs frequently, please check whether Utility grid and voltage are within the allowable range.</p> <ul style="list-style-type: none"> • If Utility gridvoltage exceeds the permissible range, please contact the local power operator. • If Utility gridvoltage is within the allowable range, it is necessary to modify the InverterGrid Undervoltage Protection point after obtaining approval from the local power operator. LVRTEnable or disable the Grid Undervoltage Protection

fault code	fault name	fault cause	Troubleshooting recommendation
			<p>function.</p> <p>3. If the issue persists for an extended period, please check whether the AC-side breaker and output cables are properly connected.</p>

fault code	fault name	fault cause	Troubleshooting recommendation
F05	10minOvervoltage Protection	In10minThe sliding average of Utility gridvoltage exceeds the safety regulation limits.	<ol style="list-style-type: none"> 1. If it occurs occasionally, it may be due to a temporary anomaly in Utility grid. Inverter will resume normal operation after detecting that Utility grid is functioning properly, without requiring manual intervention. 2. Check if Utility gridvoltage is operating at a high voltage for an extended period. If this occurs frequently, verify whether Utility gridvoltage is within the allowable range. <ul style="list-style-type: none"> • If Utility gridvoltage exceeds the permissible range, please contact the local power operator. • If the Utility gridvoltage is within the allowable range, it is necessary to obtain approval from the local power operator before modifying the Utility grid. <p>10minOvervoltage Protection point.</p>

fault code	fault name	fault cause	Troubleshooting recommendation
F06	Grid Overfrequency	Utility grid anomaly: Utility grid actual Frequency exceeds local Utility grid standard requirements.	<p>1. If it occurs occasionally, it may be due to a temporary abnormality in Utility grid. Inverter will resume normal operation after detecting that Utility grid is functioning properly, without requiring manual intervention.</p> <p>2. If it occurs frequently, check whether Utility grid and Frequency are within the allowable range.</p> <ul style="list-style-type: none"> • If the Utility grid Frequency exceeds the permissible range, please contact the local power operator. • If Utility grid Frequency is within the allowable range, the Grid Overfrequency point needs to be modified after obtaining consent from the local power operator.

fault code	fault name	fault cause	Troubleshooting recommendation
F07	Grid Underfrequency	Utility grid anomaly: Utility grid actual Frequency is lower than local Utility grid standard requirement.	<p>1. If it occurs occasionally, it may be due to a temporary anomaly in Utility grid. Inverter will resume normal operation upon detecting that Utility grid is functioning properly, without requiring manual intervention.</p> <p>2. If it occurs frequently, check whether Utility grid and Frequency are within the allowable range.</p> <ul style="list-style-type: none"> • If the Utility gridFrequency exceeds the permissible range, please contact the local power operator. • If the Utility gridFrequency is within the permissible range, the Grid Overfrequency point needs to be modified after obtaining consent from the local power operator.

fault code	fault name	fault cause	Troubleshooting recommendation
F08	Grid Frequency Instability	Utility grid anomaly: Utility grid actual Frequency variation rate does not comply with local Utility grid standard.	<p>1. If it occurs occasionally, it may be due to a temporary anomaly in Utility grid. Inverter will resume normal operation after detecting that Utility grid is functioning properly, without requiring manual intervention.</p> <p>2. If it occurs frequently, check whether Utility grid and Frequency are within the allowable range.</p> <ul style="list-style-type: none"> • If the Utility gridFrequency exceeds the permissible range, please contact the local power operator. • If the Utility grid Frequency is within the allowable range, please contact your dealer or after-sales service center.

fault code	fault name	fault cause	Troubleshooting recommendation
F163	Grid Phase Instability	Utility grid anomaly: Utility grid voltage phase variation rate does not comply with local Utility grid standards.	<p>1. If it occurs occasionally, it may be due to a temporary anomaly in Utility grid. Inverter will resume normal operation after detecting that Utility grid is functioning properly, without requiring manual intervention.</p> <p>2. If it occurs frequently, please check whether Utility grid and Frequency are within the allowable range.</p> <ul style="list-style-type: none"> • If Utility gridFrequency exceeds the permissible range, please contact the local power operator. • If the Utility gridFrequency is within the allowable range, please contact your dealer or after-sales service center.

fault code	fault name	fault cause	Troubleshooting recommendation
F09	Anti-islanding Protection	Utility grid has been disconnected, maintaining Utility grid voltage due to the presence of load. According to safety regulation Protection, on-grid has been stopped.	<p>1. If it occurs occasionally, it may be due to a temporary anomaly in Utility grid. Inverter will resume normal operation after detecting that Utility grid is functioning properly, without requiring manual intervention.</p> <p>2. If it occurs frequently, check whether the Utility grid and Frequency are within the allowable range.</p> <ul style="list-style-type: none"> • If the Utility gridFrequency exceeds the permissible range, please contact the local power operator. • If the Utility grid Frequency is within the allowable range, please contact your dealer or after-sales service center.
F10	Undervoltage ride-through	Utility grid anomaly: Grid Voltage Abnormal duration exceeds the specified high-low transition time.	

fault code	fault name	fault cause	Troubleshooting recommendation
F11	HVRT Overvoltage	Utility grid anomaly: The duration of Grid Voltage Abnormal exceeds the specified high-low transition time.	<p>1. If it occurs occasionally, it may be due to a temporary anomaly in Utility grid. Inverter will resume normal operation after detecting that Utility grid is functioning properly, without requiring manual intervention.</p> <p>2. If it occurs frequently, please check whether Utility grid, voltage, and Frequency are within the allowable range and stable. If not, contact the local power operator; if yes, contact your dealer or after-sales service center.</p>
F43	Grid Waveform Abnormal	Utility grid anomaly: Utility grid voltage detection triggered fault due to abnormality.	
F44	Grid Phase Loss	Utility grid anomaly: Utility gridvoltage has a single-phase dip.	

fault code	fault name	fault cause	Troubleshooting recommendation
F45	Grid Voltage Imbalance	Utility grid phase voltage deviation is excessive.	<p>1. If it occurs occasionally, it may be due to a temporary anomaly in Utility grid. Inverter will resume normal operation after detecting that Utility grid is functioning properly, without requiring manual intervention.</p> <p>2. If this occurs frequently, please check whether Utility grid, voltage, and Frequency are within the allowable range and stable. If not, contact the local power operator; if yes, contact your dealer or after-sales service center.</p>
F46	Grid Phase Sequence Failure	Inverter and Utility grid wiring abnormality: wiring is not in positive sequence	<p>1. Check whether the wiring of Inverter and Utility grid is in positive sequence. After the wiring is corrected (e.g., by swapping any two live wires), the fault will automatically disappear.</p> <p>2. If the wiring is correct and fault persists, please contact the dealer or after-sales service center.</p>

fault code	fault name	fault cause	Troubleshooting recommendation
F47	Grid Rapid Shutdown Protection	Quickly shut down the output upon detecting the Grid Power Outage operating condition.	1. Grid connected automatically disappears after fault is restored
F48	Grid Neutral Wire Loss	Phase splitting	1. The alarm automatically disappears after Grid connected recovery. 2. Check if the AC line or AC Switch is disconnected.
F160	EMS/Forced off-grid	EMSIssue forced off-grid command, but the off-grid function is not enabled.	Enable off-grid function
F161	Passive Anti-islanding Protection	-	-
F162	Grid Type Fault	Actual Type of Electrical Supply System (two-phase or split-phase) does not match the set safety regulations.	Switch the corresponding safety regulations according to the actual Type of Electrical Supply System.

fault code	fault name	fault cause	Troubleshooting recommendation
F12	30mAGfciProtection	During operation, the input-to-ground insulation resistance becomes low.	<p>1. If it occurs occasionally, it may be caused by temporary external line abnormalities. The system will resume normal operation after the fault is cleared, without requiring manual intervention.</p> <p>2. If it occurs frequently or cannot be restored for a long time, please check whether the PV String ground impedance is too low.</p>
F13	60mAGfciProtection	During operation, the input-to-ground insulation resistance becomes low.	<p>1. If it occurs occasionally, it may be caused by temporary abnormalities in the external circuit. The fault will resume normal operation after clearing without manual intervention.</p> <p>2. If the issue occurs frequently or cannot be resolved for an extended period, please check whether the PV String ground impedance is too low.</p>

fault code	fault name	fault cause	Troubleshooting recommendation
F14	150mAGfciProtection	During operation, the input-to-ground insulation resistance becomes low.	<p>1. If it occurs occasionally, it may be caused by temporary abnormalities in the external circuit. The system will resume normal operation after the fault is cleared, without requiring manual intervention.</p> <p>2. If the issue occurs frequently or cannot be resolved for an extended period, please check whether the PV String ground impedance is too low.</p>
F15	Gfcislowly varying Protection	During operation, the input-to-ground insulation resistance becomes low.	<p>1. If it occurs occasionally, it may be caused by temporary abnormalities in the external circuit. The fault will clear automatically and resume normal operation without manual intervention.</p> <p>2. If the issue occurs frequently or cannot be resolved for an extended period, please check whether the PV String ground impedance is too low.</p>

fault code	fault name	fault cause	Troubleshooting recommendation
F16	DCIPrimary Protection	The High DC Component of the inverter output current is outside the safety regulations or the default permissible range of the machine.	<ol style="list-style-type: none"> 1. If the abnormality is caused by an external fault, the Inverter will automatically resume normal operation after the fault disappears, without requiring manual intervention. 2. If this alarm occurs frequently and affects the normal power generation of the power station, please contact the dealer or after-sales service center.
F17	DCIsecondary Protection	The current of the inverter output is outside the safety regulations or the default permissible range of the machine.	<ol style="list-style-type: none"> 1. If the abnormality is caused by an external fault, the Inverter will automatically resume normal operation after the fault disappears, without requiring manual intervention. 2. If this alarm occurs frequently and affects the normal power generation of the power station, please contact the dealer or after-sales service center.

fault code	fault name	fault cause	Troubleshooting recommendation
F18	Low Insulation Resistance	<p>1. PV String is short-circuited to ground with Protection.</p> <p>2. The environment of PV String Installation is consistently humid with poor line-to-ground insulation.</p> <p>3. Batteryport line-to-ground Low Insulation Resistance.</p>	<p>1. Check the impedance between PV String/Battery port and ground Protection. A resistance value greater than 80kΩ is normal. If the measured resistance is less than 80kΩ, locate and rectify the short circuit point.</p> <p>2. Check whether the PE cable of the Inverter is properly connected.</p> <p>3. If it is confirmed that the impedance is indeed lower than the default value in rainy weather, please reset the Inverter "insulation resistance Protection point" via the App.</p> <p>In the Australian and New Zealand markets, when Inverter occurs, alarms can also be triggered through the following methods:</p> <p>1. Inverter is equipped with a buzzer, which will sound continuously for 1 minute when a fault occurs; if the fault is not resolved, the buzzer will sound again every 30 minutes.</p>

fault code	fault name	fault cause	Troubleshooting recommendation
			2. If Inverter is added to the monitoring platform and the alarm notification method is configured, alarm information can be sent to customers via email.
F19	Grounding Abnormal	<ol style="list-style-type: none"> 1. The PE cable of Inverter Not Connected. 2. When the output of PV String is grounded, the output side of Inverter is not connected with an isolation transformer. 	<ol style="list-style-type: none"> 1. Please confirm whether the Inverter of PE cable is functioning normally. 2. In the scenario where the output of PV String is grounded, please confirm whether the output side of Inverter is connected to an isolation transformer.
F49	L-PE Short Circuit	Output phase line toPELow impedance or short circuit	Detect output phase line toPEImpedance, identify Locations with low impedance and repair them.

fault code	fault name	fault cause	Troubleshooting recommendation
F50	DCVPrimary Protection	Abnormal load fluctuation	<p>1. If the abnormality is caused by an external fault, the Inverter will automatically resume normal operation after the fault disappears, without requiring manual intervention.</p> <p>2. If this alarm occurs frequently and affects the normal power generation of the power station, please contact the dealer or after-sales service center.</p>
F51	DCVSecondary Protection	Abnormal load fluctuation	<p>1. If the abnormality is caused by an external fault, the Inverter will automatically resume normal operation after the fault disappears, without requiring manual intervention.</p> <p>2. If this alarm occurs frequently and affects the normal power generation of the power station, please contact the dealer or after-sales service center.</p>

fault code	fault name	fault cause	Troubleshooting recommendation
F20	Hardware Export Limit Protection	Abnormal load fluctuation	<p>1. If the abnormality is caused by an external fault, the Inverter will automatically resume normal operation after the fault disappears, without requiring manual intervention.</p> <p>2. If this alarm occurs frequently and affects the normal power generation of the power station, please contact the dealer or after-sales service center.</p>
F21	Internal Comm Loss	Reference specific subcode reason	<p>Disconnect the AC output side switch and the DC input side switch.5 After a few minutes, close the AC output side switch and the DC input side switch. If fault persists, please contact the dealer or after-sales service center.</p>
F52	Leakage currentGFCIMultiple fault shutdowns	<p>North American safety standards require that after multiple fault, the system must not recover automatically and requires manual intervention or waiting.24hPost-recovery</p>	<p>1. Please check if the PV String ground impedance is too low.</p>

fault code	fault name	fault cause	Troubleshooting recommendation
F53	DC Arc Failure AFCI Multiple fault shutdowns	North American safety regulations require that after multiple fault, the system must not recover automatically and requires manual intervention or waiting. 24h Post-recovery	<ol style="list-style-type: none"> 1. After the machine is re-on-grid, check whether the voltage current of each circuit abnormally decreases to zero; 2. Check if the DC side terminal is securely connected.
F54	External communication link failure	External device communication lost, possibly due to peripheral power supply issues, Communication Protocols mismatch, or unconfigured corresponding peripherals.	Judgment is made based on the actual model and detection enable bits; peripherals not supported by certain models will not be detected.
F55	Back-upport Overload fault	1. Prevent Inverter from continuous Overload output.	1. Disconnect some off-grid loads to reduce the Inverter off-grid output Power.

fault code	fault name	fault cause	Troubleshooting recommendation
F56	Back-upport overvoltage fault	2. Prevent damage to the load caused by overvoltage in the Inverter output.	1. If it occurs occasionally, it may be caused by load switching and does not require manual intervention. 2. If it occurs frequently, please contact the dealer or after-sales service center.
F107	On-grid PWM Sync Failure	Abnormal occurrence in carrier synchronization on-grid	1Check if the synchronization line connection is normal. 2Check if the master-slave settings are normal. 3Disconnect the AC output side switch and the DC input side switch. 5 After a few minutes, close the AC output side switch and the DC input side switch. If fault persists, please contact the distributor or after-sales service center.
F57	External connectionBoxfault	waiting for Switch On-Grid to Off-GridBoxExcessive relay switching time	1. InspectionBoxIs it functioning properly; 2. InspectionBoxIs the communication wiring correct;
-	Generator Failure		

fault code	fault name	fault cause	Troubleshooting recommendation
F22	Generator waveform detection fault	<p>1. In the case of a Not Connected generator, this fault will always be displayed.</p> <p>2. During generator operation, failure to meet generator safety regulations will trigger this fault.</p>	<p>1. When the generator is not connected, ignore this fault;</p> <p>2. The occurrence of this fault when the generator experiences fault is normal. After the generator recovers, wait for a period of time, and the fault will automatically clear.</p> <p>3. The fault does not affect the normal operation of the off-grid mode.</p> <p>4. The generator and Utility grid are connected simultaneously and meet safety requirements. Utility grid takes priority on-grid and will operate in the Utility grid on-grid state.</p>
F23	Abnormal generator connection		
F24	Generator voltage low		
F25	Generator voltage high		
F26	Generator Frequency low		
F27	Generator Frequency high		
F109	External connection STS fault	Inverter and STS Abnormal connection cable	Check the Inverter and STS Is the wiring sequence of the harness connection between them one-to-one and sequentially corresponding?
F58	CT Missing fault	CT Connection wire disconnected (Japanese safety regulation requirement)	Inspection CT Is the wiring correct.

fault code	fault name	fault cause	Troubleshooting recommendation
F110	Export Limit Protection	1. Fault report and grid disconnection 2. meterUnstable communication 3. Reverse power flow condition occurs	1. Check if there are any other error messages in Inverter. If so, perform targeted troubleshooting. 2. InspectionmeterIs the connection reliable? 3. If this alarm occurs frequently and affects the normal power generation of the power station, please contact the dealer or after-sales service center.
F111	BypassOverload	-	-
F112	Black Start Failure	-	-
F28	Parallel operationIOSelf-test abnormality	Parallel communication line is not securely connected or parallel operationIOChip damage	Check if the parallel communication cable is securely connected, and then recheck.IOCheck if the chip is damaged, and if so, replace it.IOChip.
F59	Parallel operationCANComm unication abnormality	Parallel communication cable is not securely connected or some units are offline.	Check whether all machines are power on and ensure the parallel communication cables are securely connected.

fault code	fault name	fault cause	Troubleshooting recommendation
F29	Paralell Grid Line Reversed	Some machines have the Utility grid line connected in reverse with others.	Reconnect the Utility grid line.
F60	Parallel operationBack-upreverse connection	Partial machinesbackupLine reversed with other connections	reconnectionbackupLine.
F61	Inverter Soft Start Failure	Off-grid cold start Inverter Soft Start Failure	Check whether the inverter module of the machine is damaged.
F113	Offgrid AC Ins Volt High	-	-
F30	AC HCT check Abnormal	AC sensor sampling anomaly	Disconnect the AC output side switch and the DC input side switch. ⁵ After a few minutes, close the AC output side switch and the DC input side switch. If fault persists, please contact the distributor or after-sales service center.
F62	AC HCT Failure	HCTSensor anomaly detected	Disconnect the AC output side switch and the DC input side switch. ⁵ After a few minutes, close the AC output side switch and the DC input side switch. If fault persists, please contact the distributor or after-sales service center.

fault code	fault name	fault cause	Troubleshooting recommendation
F31	GFCI HCT Check Abnormal	Leakage current sensor has sampling abnormality	Disconnect the AC output side switch and the DC input side switch.5 After a few minutes, close the AC output side switch and the DC input side switch. If fault persists, please contact the distributor or after-sales service center.
F63	GFCI HCT Failure	Leakage current sensor is abnormal	Disconnect the AC output side switch and the DC input side switch.5 After a few minutes, close the AC output side switch and the DC input side switch. If fault persists, please contact the distributor or after-sales service center.
F32	Relay Check Abnormal	Relay abnormality, cause: 1Relay abnormality (relay short circuit) 2Relay sampling circuit abnormality. 3Abnormal AC side wiring (possible loose connection or short circuit)	Disconnect the AC output side switch and the DC input side switch.5 After a few minutes, close the AC output side switch and the DC input side switch. If fault persists, please contact the distributor or after-sales service center.

fault code	fault name	fault cause	Troubleshooting recommendation
F64	Relay Failure	1Relay abnormality (relay short circuit) 2Relay sampling circuit abnormality. 3Abnormal AC side wiring (possible loose connection or short circuit)	Disconnect the AC output side switch and the DC input side switch.5 After a few minutes, close the AC output side switch and the DC input side switch. If fault persists, please contact the distributor or after-sales service center.
F164	String (array)17~32)	1DC side connection terminal loose; 2DC side connection terminal loose contact; 3Core damage and poor contact	1After the machine is re-on-grid, check whether the voltage current of each circuit is abnormally reduced to zero; 2Check if the DC-side terminal is securely connected.
F165	String33~48)	1DC side connection terminal loose; 2DC side connection terminal loose contact; 3Core damage and poor contact	1After the machine is re-on-grid, check whether the voltage current of each circuit is abnormally reduced to zero. 2Check if the DC-side terminal is securely connected.
F33	FlashRead/Write Error	Possible causes: flashContent has been changed; flashEnd of life	1. Upgrade to the latest version of the program 2. Contact the dealer or after-sales service center.

fault code	fault name	fault cause	Troubleshooting recommendation
F42	String (string)1~16)	1DC side connection terminal loose; 2DC side connection terminal loose contact; 3Core damage and poor contact	1After the machine is re-on-grid, check whether the voltage current of each circuit is abnormally reduced to zero; 2Check if the DC-side terminal is securely connected.
F34	AFCI Check Failure	During the Arc Failure self-test process, the Arc Failure module failed to detect Arc Failure.	Disconnect the AC output side switch and the DC input side switch.5 After a few minutes, close the AC output side switch and the DC input side switch. If fault persists, please contact the distributor or after-sales service center.
F65	AC Terminal Overtemperature	AC Terminal Overtemperature, possible causes: 1Inverter Installation Location Non-ventilated. 2Ambient Overtemperature 3Internal fan operation abnormal.	

fault code	fault name	fault cause	Troubleshooting recommendation
F35	Cabinet Overtemperature	Cabinet Overtemperature, Possible causes: 1 Inverter Installation Location non-ventilated. 2 Ambient Overtemperature 3 Internal fan operation abnormal.	1 Check whether the ventilation of the Inverter Installation Location is adequate and whether the ambient temperature exceeds the maximum permissible ambient temperature range. 2 If there is no ventilation or Ambient
F66	INV Module temperature too high	Inverter module temperature is too high, possible causes: 1 Inverter Installation Location non-ventilated. 2 Ambient Overtemperature 3 Internal fan operation abnormal.	Overtemperature, please improve the ventilation and heat dissipation conditions. 3 If ventilation and ambient temperature are both normal, please contact the dealer or after-sales service center.

fault code	fault name	fault cause	Troubleshooting recommendation
F67	BoostModule temperature too high	BoostModule temperature too high, possible causes: 1InverterInstallation Location non-ventilated. 2Ambient Overtemperature 3Internal fan operation abnormal.	
F68	AC Capacitor Overtemperature	Output filter capacitor temperature is too high, possible causes: 1InverterInstallation Location not ventilated. 2Ambient Overtemperature 3Internal fan operation abnormal.	

fault code	fault name	fault cause	Troubleshooting recommendation
F114	Relay Failure ²	Relay abnormality, cause: 1 Relay abnormality (relay short circuit) 2 Relay sampling circuit abnormality. 3 Abnormal AC side wiring (possible loose connection or short circuit)	Disconnect the AC output side switch and the DC input side switch. ⁵ After a few minutes, close the AC output side switch and the DC input side switch. If fault persists, please contact the distributor or after-sales service center.
F69	PV IGBT short circuit	Possible causes: 1. IGBT short circuit 2. Abnormal sampling circuit	Disconnect the AC output side switch and the DC input side switch. ⁵ After a few minutes, close the AC output side switch and the DC input side switch. If fault persists, please contact the distributor or after-sales service center.
F70	PV IGBT open circuit voltage	1. Software issue caused no wave transmission. 2. Drive circuit abnormality: 3. IGBT Open Circuit	Disconnect the AC output side switch and the DC input side switch. ⁵ After a few minutes, close the AC output side switch and the DC input side switch. If fault persists, please contact the distributor or after-sales service center.

fault code	fault name	fault cause	Troubleshooting recommendation
F71	NTC abnormal	NTC temperature sensor abnormality detected	Disconnect the AC output side switch and the DC input side switch.5 After a few minutes, close the AC output side switch and the DC input side switch. If fault persists, please contact the distributor or after-sales service center.
F72	PWM Abnormal	PWM abnormal waveform detected	Disconnect the AC output side switch and the DC input side switch.5 After a few minutes, close the AC output side switch and the DC input side switch. If fault persists, please contact the distributor or after-sales service center.
F73	CPU interruption anomaly	CPU interruption anomaly occurred	Disconnect the AC output side switch and the DC input side switch.5 After a few minutes, close the AC output side switch and the DC input side switch. If fault persists, please contact the distributor or after-sales service center.
F74	Microelectronics fault	Function Safety anomaly detected	Disconnect the AC output side switch and the DC input side switch.5 After a few minutes, close the AC output side switch and the DC input side switch. If fault persists, please contact the distributor or after-sales service center.

fault code	fault name	fault cause	Troubleshooting recommendation
F75	PV HCTfault	boostcurrent sensor abnormality	Disconnect the AC output side switch and the DC input side switch.5 After a few minutes, close the AC output side switch and the DC input side switch. If fault persists, please contact the distributor or after-sales service center.
F76	1.5VBenchmark anomaly	Reference circuit	Disconnect the AC output side switch and the DC input side switch.5 After a few minutes, close the AC output side switch and the DC input side switch. If fault persists, please contact the distributor or after-sales service center.
F77	0.3VBaseline anomaly	Reference circuit	
F78	CPLDVersion identification error	CPLDVersion identification error	Disconnect the AC output side switch and the DC input side switch.5 After a few minutes, close the AC output side switch and the DC input side switch. If fault persists, please contact the distributor or after-sales service center.
F79	CPLDCommunication fault	CPLDandDSPCommunication content error or timeout	Disconnect the AC output side switch and the DC input side switch.5 After a few minutes, close the AC output side switch and the DC input side switch. If fault persists, please contact the distributor or after-sales service center.

fault code	fault name	fault cause	Troubleshooting recommendation
F80	Model Identification	Model Recognition Error's fault regarding	Disconnect the AC output side switch and the DC input side switch.5 After a few minutes, close the AC output side switch and the DC input side switch. If fault persists, please contact the distributor or after-sales service center.
F115	SVGPrecharge Disabled	SVGPrecharge hardware failure	Contact the dealer or after-sales service center.
F116	nighttimeSVG PIDPrevention of fault	PIDPrevent hardware anomalies	Contact the dealer or after-sales service center.
F117	DSPVersion identification error	DSPSoftware version identification error	Disconnect the AC output side switch and the DC input side switch.5 After a few minutes, close the AC output side switch and the DC input side switch. If fault persists, please contact the distributor or after-sales service center.
F36	Bus Overvoltage		Disconnect the AC output side switch and the DC input side switch.5 After a few minutes, close the AC output side switch and the DC input side switch. If fault persists, please contact the distributor or after-sales service center.
F81	P-Bus Overvoltage		
F82	N-Bus Overvoltage		
F83	Bus Overvoltage(Deputy CPU1)		
F84	DeputyCPU1)		

fault code	fault name	fault cause	Troubleshooting recommendation
F85	DeputyCPU1)	BUSOvervoltage, possible causes: 1. PVvoltage too high 2InverterBUSSampling anomaly 3The poor isolation effect of the rear-end double splitting causes mutual interference between the two Inverteron-grid, resulting in DC overvoltage when one of the Inverteron-grid occurs.	
F86	Bus Overvoltage(Deputy CPU2)		
F87	DeputyCPU2)		
F88	N-Bus Overvoltage(Deputy CPU2)		
F89	P-Bus Overvoltage(CPLD)		
F90	Complex Programmable Logic Device (CPLD)		
F118	MOSContinuous Overvoltage	1. Software issue causes the inverter drive to shut down earlier than the flyback drive. 2. Inverter drive circuit abnormality prevents turn-on. 3. PVvoltage too high 4. MosSampling anomaly	Disconnect the AC output side switch and the DC input side switch.5 After a few minutes, close the AC output side switch and the DC input side switch. If fault persists, please contact the distributor or after-sales service center.

fault code	fault name	fault cause	Troubleshooting recommendation
F119	Busbar short circuit	1. Hardware damage	In case of occurrence BUS After a short circuit fault, the Inverter remains in an off-grid state. Please contact the dealer or after-sales service center.
F120	Abnormal bus sampling	1. Bus Sampling hardware	Disconnect the AC output side switch and the DC input side switch.5 After a few minutes, close the AC output side switch and the DC input side switch. If fault persists, please contact the distributor or after-sales service center.
F121	DC Lateral sampling abnormality	1. Bus sampling hardware 2. Battery Voltage Sampling Hardware fault 3. Dcrly Relay Failure	Disconnect the AC output side switch and the DC input side switch.5 After a few minutes, close the AC output side switch and the DC input side switch. If fault persists, please contact the distributor or after-sales service center.

fault code	fault name	fault cause	Troubleshooting recommendation
F37	PVInput overvoltage	PVvoltage input too high, possible causes: Incorrect PV array configuration, with too many PV Battery panels connected in series, causing the open-circuit voltage of the string to exceed the maximum operating voltage of the Inverter.	Check the series configuration of the corresponding PV array strings to ensure that the open-circuit voltage of the strings does not exceed the maximum working voltage of the Inverter. Once the PV array is correctly configured, the Inverter alarm will automatically disappear.
F38	PVContinuous Hardware Overcurrent	1. Unreasonable module configuration 2. Hardware damage	Disconnect the AC output side switch and the DC input side switch.5After a few minutes, close the AC output side switch and the DC input side switch. If fault persists, please contact the distributor or after-sales service center.
F39	PVContinuous software overcurrent	1. Unreasonable module configuration 2. Hardware damage	
F91	FlyCap Software Overvoltage	Flying capacitor overvoltage, possible causes: 1. PVvoltage too high 2Inverter Flying Capacitor voltage Sampling Anomaly	

fault code	fault name	fault cause	Troubleshooting recommendation
F92	FlyCap Hardware Overvoltage	Flying capacitor overvoltage, possible causes: 1. PVvoltage too high 2InverterFlying capacitorvoltageSa mpling anomaly	Disconnect the AC output side switch and the DC input side switch.5After a few minutes, close the AC output side switch and the DC input side switch. If fault persists, please contact the distributor or after-sales service center.
F93	FlyCap Undervoltage	FlyCap Undervoltage, possible causes: 1. PVEnergy deficiency; 2Flying capacitor sampling anomaly	
F94	FlyCap Precharge Failure	FlyCap Precharge Failure, Possible causes: 1. PVEnergy deficiency; 2InverterFlying CapacitorvoltageSa mpling Anomaly	
F95	FlyCap Precharge Abnormal	1. Unreasonable control loop parameters 2. Hardware damage	
F96	String overcurrent(String1 ~16)		

fault code	fault name	fault cause	Troubleshooting recommendation
F97	String overcurrent(String17~32)	Possible causes: 1. String Overcurrent 2. String current sensor anomaly	
F40	String reverse connection(String1~16)	PVString reverse connection	Check if the strings are reversed.
F98	String reverse connection(String17~32)	PVString reverse connection	Check if the string is reverse connected.
F99	String loss(String1~16)	String fuse disconnected (if applicable)	Check if the fuse is blown.
F100	String loss(String17~32)	String fuse disconnected (if applicable)	Check if the fuse is blown.

fault code	fault name	fault cause	Troubleshooting recommendation
F122	PVAccess Mode setting error	<p>PVAccess Mode has three modes, with four channelsMPPTFor example:</p> <ol style="list-style-type: none"> 1. Parallel mode: that isAAAAMode(homologous mode),PV1-PV4Homologous,4RoadPVConnect the same photovoltaic panel 2. Partial Parallel Mode: i.e.AACCMode,PV1andPV2Homologous connection,PV3andPV4homologous connection 3. Stand-alone mode: i.e.ABCDMode(non-homologous),PV1、PV2、PV3、PV4Independent connection,4RoadPVEach connected to a photovoltaic panel <p>IfPVThe actual Access Mode and the equipment</p>	<p>InspectionPVIIs Access Mode correctly set (ABCD、AACC、AAAAReset in the correct mannerPVAccess Mode</p> <ol style="list-style-type: none"> 1. Confirm the actual connected circuitsPVIIs the connection correct. 2. IfPVCorrectly connected, passedAppor screen to check the current settingsPVAccess Mode" corresponds to the actual Access Mode. 3. If the currently setPVAccess Mode" does not match the actual Access Mode and requires adjustment.Appor the screen willPVAccess Mode is set to a mode consistent with actual conditions. After the setting is completed,PVandACPower supply disconnection and restart. 4. After the setup is completed, if the currentPVAccess Mode matches the actual Access Mode, but this fault is still reported. Please contact the dealer or after-sales

fault code	fault name	fault cause	Troubleshooting recommendation
		settingsPVThis fault will be reported if Access Mode does not match.	service center.
-	String reverse connection(String33~48)	PVString reverse connection	Check if the strings are reversed.
-	String loss(String33~48)	String fuse disconnected (if applicable)	Check if the fuse is blown.
-	String overcurrent(String33~48)	Possible causes: 1. String Overcurrent 2. String current sensor anomaly	

fault code	fault name	fault cause	Troubleshooting recommendation
F123	Multi-channel PV phase error	PV input mode setting error	<p>Check if the PVAccess Mode is correctly set (ABCD, AACC, AAAA), and reset the PVAccess Mode in the correct manner. Verify that each connected PV string is correctly wired.</p> <p>2. If the PV is correctly connected, check via the App or screen whether the currently set "PVAccess Mode" corresponds to the actual Access Mode.</p> <p>3. If the currently set "PV Access Mode" does not match the actual Access Mode, it is necessary to use the App or screen to set the "PV Access Mode" to the mode consistent with the actual situation. After the setting is completed, disconnect the PV and AC power supply and restart.</p> <p>4. After the setup is completed, if the current "PVAccess Mode" matches the actual Access Mode but this fault still appears, please contact the dealer or after-sales service center.</p>

fault code	fault name	fault cause	Troubleshooting recommendation
F101	Battery1Precharge fault	Battery1Pre-Charge circuit fault (such as pre-Charge resistance burnout, etc.)	Check if the pre-Charge circuit is in good condition, ensure that only the Battery power on matches the Battery Voltage and busbar voltage. If they do not match, please contact the dealer or after-sales service center.
F102	Battery1Relay Failure	Battery1The relay fails to operate normally.	After Battery power on, check whether the Battery relay operates and if the closing sound is heard. If it does not function, please contact the dealer or after-sales service center.
F103	Battery1overvoltage at connection point	Battery1The voltage access exceeds the rated range of the machine.	Verify if Battery Voltage is within the machine's rated range.
F104	Battery2Precharge fault	Battery2Pre-Charge circuit fault (such as pre-Charge resistor burnout, etc.)	Check whether the pre-Charge circuit is in good condition, and verify that the Battery power on post-Battery Voltage matches the busbar voltage. If they do not match, please contact the dealer or after-sales service center.

fault code	fault name	fault cause	Troubleshooting recommendation
F105	Battery2Relay Failure	Battery2The relay fails to operate normally.	After Battery power on, check if the Battery relay operates and if the closing sound is heard. If it does not function, please contact the dealer or after-sales service center.
F106	Battery2overvoltage at connection point	Battery2The input voltage exceeds the rated range of the machine.	Verify if Battery Voltage is within the machine's rated range.
F124	Battery1Reverse connection	Battery1Reverse polarity of positive and negative terminals	Check whether the polarity of Battery and the machine terminal is consistent.
F125	Battery2Reverse polarity fault	Battery2Reverse polarity of positive and negative terminals	Check whether the polarity of Battery and the machine terminals is consistent.
F126	Abnormal Access	Abnormal connection of Battery	Check if the Battery is functioning properly.
-	BMS Status Bit Error	BMS Module	Disconnect the AC output side switch and DC input side switch, then close the AC output side switch and DC input side switch after 5 minutes. If fault persists, please contact the distributor or after-sales service center.

fault code	fault name	fault cause	Troubleshooting recommendation
F127	BAT Overtemperature	Battery temperature is too high, possible causes: 1 Inverter Installation Location non-ventilated. 2 Ambient Overtemperature 3 Internal fan operation abnormal.	
F128	Ref Voltage Abnormal	Reference circuit	Disconnect the AC output side switch and the DC input side switch.5 After a few minutes, close the AC output side switch and the DC input side switch. If fault persists, please contact the distributor or after-sales service center.
F129	Cabinet Under Temperature	Cabinet Under Temperature, Possible causes: 1. The ambient temperature is too low.	
F130	ACsideSPDfault	ACFailure of lateral lightning protection device	ReplacementACLateral lightning protection device.
F131	DCsideSPDfault	DCFailure of lateral lightning protection device	ReplacementDCSide lightning protection device.

fault code	fault name	fault cause	Troubleshooting recommendation
F132	Internal Fan Abnormal	Internal Fan Abnormal, possible causes: 1Abnormal fan power supply; 2Mechanical fault(Locked rotor); 3Fan aging and damage.	Disconnect the AC output side switch and the DC input side switch.5 After a few minutes, close the AC output side switch and the DC input side switch. If fault persists, please contact the distributor or after-sales service center.
F133	External Fan Abnormal	External Fan Abnormal, Possible causes: 1Abnormal fan power supply; 2Mechanical fault(Locked rotor); 3Fan aging and damage.	
F134	PIDDiagnose abnormality	PIDHardware fault orPVvoltage too highPIDPause	PVOvertoltage caused by voltagePIDSuspend WARNING without processing,PIDHardware fault can be turned off.PIDSwitch Reopen ClearPIDfault, replacementPIDdevice

fault code	fault name	fault cause	Troubleshooting recommendation
F135	Trip-Switch Trip Warning	Possible causes: Overcurrent or PVReverse connection causes the trip switch to trip.	Please contact the dealer or after-sales service center. The reason for disconnection is due to a fault occurrence. PVShort circuit or reverse connection, need to check if there is a history. PVShort circuit WARNING or history PVReverse connection of WARNING. If present, maintenance personnel should inspect the corresponding component. PV Situation. After confirming there is no fault, manually close the trip switch and proceed with AppInterface Clear History fault Operation Clears This WARNING.

fault code	fault name	fault cause	Troubleshooting recommendation
F136	HistoryPV IGBT short circuit	Possible causes: Overcurrent caused the trip switch to open.	Please contact the dealer or after-sales service center. Maintenance personnel should follow the historicalPVShort circuit WARNING subcode, check for short circuit occurrenceBoostCheck if there is any fault in the hardware and external string; after confirming there is no fault, it can pass.AppInterface Clear History fault Operation Clears This WARNING.
F137	HistoryPVReverse connection WARNING(String1~16)	Possible causes: occurrencePVReverse connection causes the trip switch to trip.	Contact the dealer or after-sales service center. Maintenance personnel should follow the historicalPVReverse polarity WARNING subcode, check whether the corresponding string has reverse polarity, inspectPVIIs there a voltage difference in the panel configuration? After the inspection is completed and no fault is found, it can be passed.AppInterface Clear History fault Operation Clears This WARNING.

fault code	fault name	fault cause	Troubleshooting recommendation
F138	HistoryPVReverse connection(String17~32)	Possible causes: occurrencePVReverse connection causes the trip switch to trip.	Contact the dealer or after-sales service center. Maintenance personnel must follow the historicalPVReverse connection WARNING subcode, check whether the corresponding string has a reverse connection, inspectPVIIs there a voltage difference in the panel configuration? After checking and confirming no fault, it can be passed.AppInterface Clear History fault Operation Clears This WARNING.
F139	FlashRead/write error	Possible causes: flashContent has been changed;flashEnd of life	<ol style="list-style-type: none"> 1. Upgrade to the latest version of the program. 2. Contact the dealer or after-sales service center.

fault code	fault name	fault cause	Troubleshooting recommendation
F140	Meter Comm Loss	This WARNING may only be reported after enabling the Power Limit function. Possible causes: 1. Meter not connected; 2. The communication line connection between the meter and Inverter is incorrect.	Check the meter wiring and ensure the meter is correctly connected. If fault persists after inspection, please contact the dealer or after-sales service center.
F141	PVPanel type identification failed	PVPanel identification hardware anomaly	Contact the dealer or after-sales service center.
F142	PV String Mismatch	PVPV String Mismatch, same circuitMPPTThe configurations of the next two strings open-circuit voltage are different.	Check the two strings open-circuit voltage and configure the strings with the same open-circuit voltage to the same circuit.MPPTProlonged PV String Mismatch poses safety hazards.
F143	CTNot connected	CTNot connected	InspectionCTWiring.
F144	CTReverse connection	CTReverse connection	InspectionCTWiring.
F145	PE Loss/PE Loss	Ground wire not connected	Check the ground wire.

fault code	fault name	fault cause	Troubleshooting recommendation
F146	String terminal temperature high(String1~8)	37176RegisterPVterminal temperature alarm subcode1Set	-
F147	String terminal temperature high(String9~16)	37177RegisterPVterminal temperature alarm subcode2Set	-
F148	String terminal temperature high(String17~20)	37178registerPVterminal temperature alarm subcode3Set position	-
F149	HistoryPVReverse connection WARNING(String33~48)	Possible causes: occurrencePVReverse connection causes the trip switch to trip.	Please contact the dealer or after-sales service center; maintenance personnel must follow the history.PVReverse connection WARNING subcode, check whether the corresponding string has a reverse connection, inspectPVIIs there a voltage difference in the panel configuration? After checking and confirming no fault, it can be passed.AppInterface Clear History fault Operation Clears This WARNING.
F150	Battery1voltage low	Battery Voltage is below the set value	-
F151	Battery2voltage low	Battery Voltage is below the set value	-
F152	Low Voltage of Battery Power	Non-Charge mode, voltage below shutdown voltage	-

fault code	fault name	fault cause	Troubleshooting recommendation
F153	BAT1 Voltage High	-	-
F154	Battery2voltageHigh	-	-
F155	Online Low Insulation Resistance	<p>PV String is short-circuited to ground with Protection.</p> <p>2. The environment of PV StringInstallation is consistently humid with poor line-to-ground insulation.</p>	<p>1. Check the impedance between PV String and ground. If a short circuit is found, rectify the short circuit point.</p> <p>2. Check whether the PE cable of the Inverter is properly connected.</p> <p>3. If it is confirmed that the impedance is indeed lower than the default value under rainy or cloudy conditions, please reset the "insulation resistanceProtection point".</p>
F156	Micro-grid Overload Warning	Excessive input at the backup end	Occasional occurrences require no action; if this alarm appears frequently, please contact the dealer or after-sales service center.
F157	Manual Reset	-	-
F158	Generator Phase Sequence Abnormal	-	-

fault code	fault name	fault cause	Troubleshooting recommendation
F159	Multiplexed Port Configuration Abnormal	Reuse (Generator) port configured as a microgrid or large load, but actually connected to a generator.	Use the App to modify the reuse (generator) port configuration.
F41	Generator Port Overload	<ol style="list-style-type: none"> 1. Off-grid side output exceeds the requirements specified in the specification. 2. Off-grid side short circuit 3. Off-grid terminal voltage too low 4. When used as a high-power load port, the load exceeds the specifications stated in the datasheet. 	By verifying the data, confirm the output parameters such as voltage, current, and Power on the off-grid side to identify the cause of the issue.
F108	DSP Communication Failure	-	-

fault name	fault cause	Troubleshooting recommendation
Parallel Comm Timeout Shutdown	In parallel operation, if the slave unit exceeds 400ms No communication from the host within seconds	Check whether the parallel communication harness is securely connected and verify that there are no duplicate slave addresses.
One-key shutdown and stop	Check if the one-touch shutdown function is enabled via the App.	Deactivate one-touch shutdown.
Offline Shutdown	-	-
Remote shutdown	-	-
Child Node Communication Failure	Internal Comm Abnormal	Restart the machine and observe whether fault is eliminated.
DG Communication Failure	Abnormal communication link between the control board and the diesel generator	<ol style="list-style-type: none"> 1. Check the link communication harness and observe whether fault is eliminated. 2. Attempt to restart the machine and observe whether the fault is eliminated; 3. If the fault persists after restarting, please contact the after-sales service center.
Battery Over Voltage	<ol style="list-style-type: none"> 1. The voltage of a single cell is too high. 2. Abnormal voltage collection line 	

fault name	fault cause	Troubleshooting recommendation
	Battery total pressure too high 2. Abnormal voltage collection line	Record the fault phenomenon, restart the Battery, wait for a few minutes, and confirm whether the fault disappears. If the problem persists after restarting, please contact the after-sales service center.
Battery Undervoltage	1. Single cell voltage too low 2. voltage Acquisition Line Anomaly	
	1. Battery Total pressure too low 2. Abnormal voltage collection line	
Battery Overcurrent	1. Charging Current is too large, Battery current limiting is abnormal: temperature and voltage value suddenly change 2. Inverter response anomaly	
	Battery discharge current is too large	
Battery Overtemperature	1. Ambient Overtemperature 2. Temperature sensor abnormality	
	1. Ambient Overtemperature 2. Temperature sensor abnormality	
Battery Undertemperature	1. Ambient temperature is too low 2. Temperature sensor abnormality	
	1. Ambient temperature is too low 2. Temperature sensor abnormality	
Battery Terminal Overtemperature	Pole temperature too high	

fault name	fault cause	Troubleshooting recommendation
Battery Imbalance	<ol style="list-style-type: none"> 1. Excessive temperature difference in different stages. Battery will impose restrictions on Battery Power, that is, limit the charging of Discharge current. Therefore, this issue is generally unlikely to occur. 2. The capacity of the battery cell degrades, leading to excessive internal resistance, resulting in significant temperature rise and large temperature differences during Overcurrent. 3. Poor welding of battery cell tabs, leading to excessive temperature rise in the Overcurrent cell. 4. Temperature sampling issue; 5. Loose power cable connection 	
	<ol style="list-style-type: none"> 1. Inconsistent aging levels of battery cells 2. Issues with the board chips can also lead to excessive voltage differences in the battery cells. 3. Imbalance issues in the battery pack can also lead to excessive voltage differences between cells. 4. Harness issues leading to 	
	<ol style="list-style-type: none"> 1. Inconsistent aging levels of battery cells 2. Issues with the board chips can also lead to excessive voltage differences between battery cells. 3. Imbalance issues in the board can also lead to excessive voltage differences between cells. 4. Harness issue causing 	

fault name	fault cause	Troubleshooting recommendation
Insulation Resistance	Insulation resistance failure	Check if the ground wire is properly connected and restart the Battery. If the issue persists after restarting, please contact the after-sales service center.
Pre-charging Failurefault	Pre-charging Failure	It indicates that during the precharge process, the voltage across the precharge MOS always exceeds the specified threshold. After restarting the system, observe whether this fault persists, and check whether the wiring is correct and whether the precharge MOS is damaged.
Harvesting line	Collection line Battery is disconnected or broken	Check the wiring and restart the Battery. If the issue persists after restarting, please contact the after-sales service center.
	Single voltage collection line poor contact or disconnected	Check the wiring and restart the Battery. If the issue persists after restarting, please contact the after-sales service center.
	Single cell temperature acquisition line poor contact or disconnected	
	Dual-channel current comparison error is too large, or current acquisition line circuit is abnormal.	

fault name	fault cause	Troubleshooting recommendation
	Dual-channel voltage comparison error is too large, or the comparison error between MCU and AFE voltage is too large, or the voltage acquisition line loop is abnormal.	
	Temperature acquisition line circuit abnormal or poor contact, disconnected	
	Overvoltage level 5 or overtemperature level 5, fuse the three-terminal fuse	To replace the three-section fuse, please contact the after-sales service center to replace the main control board.
Relay or MOSFET overtemperature	Relay or MOSFET overtemperature	The fault indicates that the MOSFET temperature has exceeded the specified threshold. Power off and let it stand for 2 hours to allow temperature recovery.
Shunt Over-temperature	Shunt Over-temperature	The fault indicates that the shunt tube temperature has exceeded the specified threshold. Power off and allow it to stand for 2 hours to wait for temperature recovery.

fault name	fault cause	Troubleshooting recommendation
BMS1 Other fault1 (Residential Storage Category)	Relay or MOS open circuit	<ol style="list-style-type: none"> 1. Upgrade the software, power off and let it sit for 5 minutes, then check if fault persists after restarting. 2. If the issue persists, replace the Battery package.
	Relay or MOSFET short circuit	<ol style="list-style-type: none"> 1. Upgrade the software, power off and let it sit for 5 minutes, then check if fault persists after restarting. 2. If the issue persists, replace the Battery package.
	Communication abnormality between the master cluster and slave cluster, or inconsistency of battery cells between clusters.	<ol style="list-style-type: none"> 1. Check the Battery information and software version of the slave unit, as well as whether the communication line connection with the master unit is normal. 2. Upgrade the software
	Abnormal circuit harness in Battery system, resulting in no loop formation in interlocking signal	Check if Terminal resistor Installation is correct

fault name	fault cause	Troubleshooting recommendation
	Abnormal communication between BMS and PCS	<ol style="list-style-type: none"> 1. Verify that the communication line interface definition between Inverter and Battery is correct. 2. Please contact the after-sales service center to check the backend data and verify whether the Inverter and Battery software are correctly matched.
	Abnormal communication harness between BMS master and slave control	<ol style="list-style-type: none"> 1. Check the wiring and restart the Battery; 2. Upgrade the Battery. If the issue persists after restarting, please contact the after-sales service center.
	Communication loss between main and auxiliary chips	
	Circuit breaker, shunt trip abnormality	<p>Let the system stand powered off for 5 minutes, then restart and check if fault persists.</p> <ol style="list-style-type: none"> 2. Check whether the blind mating connectors and communication pins at the bottom of the PACK and PCU are loose or misaligned.

fault name	fault cause	Troubleshooting recommendation
	MCU self-test failed	Upgrade the software and restart the Battery. If the issue persists after restarting, contact the after-sales service center.
	<ol style="list-style-type: none"> 1. The software version is too low or the BMS board is damaged. 2. The number of Inverter parallel units is large, and the Battery experiences excessive impact during pre-charging. 	<ol style="list-style-type: none"> 1. Upgrade the software and observe whether fault persists. 2. In the case of parallel operation, perform a black start on Battery before starting Inverter.
	Internal fault of MCU	Upgrade the software and restart the Battery. Typically, this issue is caused by a damaged MCU or external component. If the problem persists after restarting, please contact the after-sales service center.
	Total control current exceeds the specified threshold	<ol style="list-style-type: none"> 1. Let the system stand idle for 5 minutes, then restart and check if fault persists. 2. Check if the Inverter is set with an excessively large Power, causing it to exceed the bus load.

fault name	fault cause	Troubleshooting recommendation
	Cell inconsistency in parallel clusters	Confirm whether the cells in the cluster Battery are consistent.
	Cluster Battery reverse polarity of positive and negative terminals	Check whether the positive and negative terminals of the string combiner Battery are reversed.
	Severe overheating or overvoltage triggers the fire protection system.	Contact the after-sales service center.
Air Conditioner Failure	Abnormal failure of air conditioning	Try restarting the system. If the fault persists, please contact the after-sales service center.
	Cabinet door not closed	Check whether the cabinet door is properly closed.
	Power supply voltage overvoltage	Verify that the power supply voltage value meets the air conditioning input voltage requirements, and proceed with re-power on only after confirmation.
	Insufficient power supply	
	No voltage input	
	Unstable power supply voltage	
	Compressor instability	Try restarting the system. If the fault persists, please contact the after-sales service center.
	Sensor poor contact or damaged	
Abnormal air conditioning fan		

fault name	fault cause	Troubleshooting recommendation
BMS1 Other fault2 (Residential Storage Category)	There is an internal voltage or current abnormality in the DCDC.	Please refer to the specific DC Failure content.
	DCDCOverload or heat sink temperature too high	
	Abnormal cell acquisition or inconsistent aging levels	Please contact the after-sales service center.
	Fan operation not executed properly	Please contact the after-sales service center.
	Output port screw loose or poor contact	<ol style="list-style-type: none"> 1. Battery Shut down, check the wiring and output port screw status 2. After confirmation, restart the Battery and observe whether the fault persists. If it does, please contact the after-sales service center.
	Battery has been used for too long or the battery cell is severely damaged.	Please contact the after-sales service center to replace the pack.
	<p>The software version is too low or the BMS board is damaged.</p> <p>2. A large number of Inverter parallel units result in excessive impact during Battery pre-charging.</p>	<p>Upgrade the software and observe whether fault persists.</p> <p>2. In the case of parallel operation, perform a black start on Battery first, then start Inverter.</p>
	Heating film damaged	Please contact the after-sales service center.

fault name	fault cause	Troubleshooting recommendation
	The three-terminal fuse of the heating film is blown, rendering the heating function unusable.	Please contact the after-sales service center.
	Software model, Cell Type, and hardware model mismatch.	Check whether the software model, serial number (SN), Cell Type, and hardware model are consistent. If they are inconsistent, please contact the after-sales service center.
	Thermal management board communication disconnection	Let the system stand powered off for 5 minutes, then restart to check if fault persists. 2. If the fault is not restored, contact after-sales service to replace the pack.
	Thermal management board communication disconnection	Let the system stand powered off for 5 minutes, then restart and check if fault persists. 2. If the fault is not restored, contact after-sales service to replace the pack.

fault name	fault cause	Troubleshooting recommendation
	Thermal management board communication disconnection	<p>Let the system stand powered off for 5 minutes, then restart and check if fault persists.</p> <p>2. If the fault is not restored, contact after-sales service to replace the pack.</p>
	pack fan fault signal trigger	<p>Let the system stand powered off for 5 minutes, then restart and check if fault persists.</p> <p>2. If the fault is not restored, contact after-sales service to replace the pack.</p>
DC combiner box	Output portvoltage too high	<p>Check the output portvoltage. If the output portvoltage is normal and the fault still cannot be resolved after restarting Battery, please contact the after-sales service center.</p>

fault name	fault cause	Troubleshooting recommendation
	The DCDC module detected that the Battery Voltage exceeded the maximum Charge voltage.	Stop Charge and Discharge until SOC drops below 90% or remains idle for 2 hours. If the issue persists and restarting fault does not resolve it, please contact the after-sales service center.
	Radiator temperature too high	Let it stand for 1 hour until the radiator temperature decreases. If the issue persists and restarting the fault does not resolve it, please contact the after-sales service center.
	Battery discharge current is too large	Check if the load exceeds the Battery's Discharge capability. Turn off the load or stop the PCS for 60 seconds. If the issue persists after restarting fault, please contact the after-sales service center.
	Output port power harness positive and negative poles are reversed with the combiner box Battery or PCS.	Turn off the Battery manual switch, check if the output port wiring is correct, and restart the Battery.

fault name	fault cause	Troubleshooting recommendation
	The output Power relay cannot close.	Check whether the output port wiring is correct and if there is a short circuit. If the issue persists after restarting fault, please contact the after-sales service center.
	Power device temperature too high	Let the Battery stand for 1 hour to allow the internal Power components of the Battery to cool down. If the issue persists and restarting the fault does not resolve it, please contact the after-sales service center.
	Relay sticking	Restart fault still exists. Please contact the after-sales service center.
Battery Rack Circulating Current Failure	<ol style="list-style-type: none"> 1. Cell imbalance 2. First power on undercharge correction 	-

fault name	fault cause	Troubleshooting recommendation
BMS1 Other fault3 (Large Storage Category)	Communication exception with Linux module	<ol style="list-style-type: none"> 1. Check if the communication link is functioning properly. 2. Upgrade the software, restart the Battery, and observe whether the fault persists. If it does, please contact the after-sales service center.
	Excessive temperature rise of the battery cell	Abnormal battery cell, contact after-sales service to replace the pack.
	SOC below 10%	Perform Charge on Battery.
	SN writing does not comply with the rules	Check whether the SN digits are normal. If abnormal, please contact the after-sales service center.
	<ol style="list-style-type: none"> 1. Battery Intra-cluster daisy chain communication anomaly 2. Inconsistent aging levels of battery cells within Battery clusters 	<ol style="list-style-type: none"> 1. Check the contact condition of a single Battery pack. 2. Confirm the usage of each cluster Battery, such as cumulative charge Discharge capacity, number of cycles, etc. 3. Please contact the after-sales service center.

fault name	fault cause	Troubleshooting recommendation
	Excessive Humidity within the pack	-
	Fuse blown	Contact after-sales service to replace the pack.
	Low battery power	Perform Charge on Battery.
BMS1 Other fault4 (Large Storage Category)	Circuit breaker anomaly	Contact after-sales service to replace the pack.
	External device abnormality	Contact after-sales service to replace the pack.
Contactactor Failure 1	-	-
Contactactor Failure 2	-	-
Jinggui	Continuous Overload (over 690KVA) for 10s	Please contact the after-sales service center.
OverloadProtection(Smart port)	Continuous Overload (exceeding 690kVA) for 10s	Please contact the after-sales service center.
Master AC On Meter Comm Error	1. The meter may not be connected to the host. 2. Possible loose communication cable of the electric meter.	1. Check if the meter is connected to the main unit. 2. Check if the meter communication cable is loose.
Parallel Slave Meter Error	The meter is connected to the slave unit.	The meter connection machine is set as the master unit.

fault name	fault cause	Troubleshooting recommendation
Slave AC On Timeout with Master	1. Incorrect slave address setting 2. Slave communication line is loose	1. Check if the slave address is duplicated. 2. Check if the parallel communication cable is loose.

8.5.2.2 Battery Fault

No.	Fault Name	Fault Cause	Fault Handling Suggestion
1	BMS1 RACK1 Total voltage is too high warning	1. Battery system voltage is too high. 2. Voltage acquisition line is abnormal.	1. Discharge the battery and observe if the fault persists. 2. If the fault does not recover, contact the after-sales service center.

No.	Fault Name	Fault Cause	Fault Handling Suggestion
2	BMS1 RACK1 Total voltage is too low warning	<ol style="list-style-type: none"> 1. Battery system voltage is too low. 2. Voltage acquisition line is abnormal. 	<ol style="list-style-type: none"> 1. Charge the battery, let it rest, and observe if the fault persists. 2. Check the inverter's working condition to see if it is not charging the battery due to issues like working mode. Try charging the battery via the inverter and observe if the fault recovers. 3. If the fault does not recover, contact the after-sales service center.
3	BMS1 RACK1 Cell voltage is too high warning	<ol style="list-style-type: none"> 1. Single cell voltage is too high. 2. Voltage acquisition line is abnormal. 	<ol style="list-style-type: none"> 1. Discharge the battery, let it rest, and observe if the fault persists. 2. If the fault does not recover, contact the after-sales service center.

No.	Fault Name	Fault Cause	Fault Handling Suggestion
4	BMS1 RACK1 Cell voltage is too low warning	<ol style="list-style-type: none"> 1. Single cell voltage is too low. 2. Voltage acquisition line is abnormal. 	<ol style="list-style-type: none"> 1. Charge the battery, let it rest, and observe if the fault persists. 2. Check the inverter's working condition to see if it is not charging the battery due to issues like working mode. Try charging the battery via the inverter and observe if the fault recovers. 3. If the fault does not recover, contact after-sales.
5	BMS1 RACK1 Charging temperature is too high warning	<ol style="list-style-type: none"> 1. Ambient Overtemperature 2. Temperature sensor is abnormal. 	<ol style="list-style-type: none"> 1. Stop charging/discharging, let it rest, and observe if the fault persists. 2. If the fault does not recover, contact the after-sales service center.

No.	Fault Name	Fault Cause	Fault Handling Suggestion
6	BMS1 RACK1 Discharging temperature is too high warning	<ol style="list-style-type: none"> 1. Ambient Overtemperature 2. Temperature sensor is abnormal. 	<ol style="list-style-type: none"> 1. Stop charging/discharging, let it rest, and observe if the fault persists. 2. If the fault does not recover, contact after-sales.
7	BMS1 RACK1 Charging temperature is too low warning	<ol style="list-style-type: none"> 1. Ambient temperature is too low. 2. Temperature sensor is abnormal. 	<ol style="list-style-type: none"> 1. Check the cell temperature in the background. If the minimum temperature is above -20°C, set the battery to discharge to increase the cell temperature. 2. If the temperature is below -20°C, power off the battery and place it in a warm environment. Use it after the cell temperature rises. 3. If none of the above works, contact the after-sales service center.

No.	Fault Name	Fault Cause	Fault Handling Suggestion
8	BMS1 RACK1 Discharging temperature is too low warning	<ol style="list-style-type: none"> 1. Ambient temperature is too low. 2. Temperature sensor is abnormal. 	<ol style="list-style-type: none"> 1. Check the cell temperature in the background. If the minimum temperature is above -20°C, set the battery to discharge to increase the cell temperature. 2. If the temperature is below -20°C, power off the battery and place it in a warm environment. Use it after the cell temperature rises. 3. If none of the above works, contact the after-sales service center.
9	BMS1 RACK1 Charge overcurrent warning	<ol style="list-style-type: none"> 1. Charging current is too high, battery current limiting is abnormal: sudden changes in temperature and voltage values. 2. Inverter response is abnormal. 	<ol style="list-style-type: none"> 1. Stop charging, let it rest, and observe if the fault persists. 2. Check if the inverter is set to a power output that exceeds the battery's rated operating current. 3. If overcurrent persists, contact the after-sales service center.

No.	Fault Name	Fault Cause	Fault Handling Suggestion
10	BMS1 RACK1 Discharge overcurrent warning	1. Discharging current is too high, battery current limiting is abnormal: sudden changes in temperature and voltage values. 2. Inverter response is abnormal.	1. Stop discharging, let it rest, and observe if the fault persists. 2. Check if the inverter is set to a power output that exceeds the battery's rated operating current. 3. If overcurrent persists, contact the after-sales service center.
11	BMS1 RACK1 Insulation resistance is too low warning	Insulation resistance is damaged or contact is abnormal.	Check if the ground wire is properly connected, restart the battery. If the problem persists after restarting, please contact the after-sales service center.

No.	Fault Name	Fault Cause	Fault Handling Suggestion
12	BMS1 RACK1 Cell excessive temperature differentials warning	<p>1. At different stages of excessive temperature differential, the battery will limit the battery power, i.e., limit the charge/discharge current. Therefore, this problem is generally difficult to occur.</p> <p>2. Cell capacity degradation leads to excessive internal resistance, causing large temperature rise during overcurrent, resulting in large temperature differential.</p> <p>3. Poor welding of cell tabs leads to rapid cell temperature rise during overcurrent.</p> <p>4. Temperature sampling issue.</p> <p>5. Power line connection is loose.</p>	Power off, restart the battery, wait for 2 hours. If the problem is not resolved, contact the after-sales service center.

No.	Fault Name	Fault Cause	Fault Handling Suggestion
13	BMS1 RACK1 Post temperature is too high warning	Post temperature is too high.	<ol style="list-style-type: none"> 1. Stop charging/discharging, let it rest, and observe if the fault persists. 2. If the fault does not recover, contact the after-sales service center.
14	BMS1 RACK1 Cell excessive voltage differentials warning	<ol style="list-style-type: none"> 1. Inconsistent cell aging levels. 2. Issues with the slave board chip can also cause excessive cell voltage differential. 3. Slave board balancing issues can also cause excessive cell voltage differential. 4. Caused by wiring harness issues. 	<ol style="list-style-type: none"> 1. Stop charging/discharging, let it rest, and observe if the fault persists. 2. If the fault does not recover, contact the after-sales service center.
15	BMS1 RACK1 PCS communication loss warning	Communication between BMS and PCS is abnormal.	Check if the communication cable connection between the battery and the inverter is intact.
16	BMS1 RACK1 DCDC warning	Internal voltage or current abnormality exists in the DCDC.	Upgrade the software, restart the battery. If the problem persists after restarting, please contact the after-sales service center.
17	BMS1 RACK1 Heat film MOS adhesion warning	Heating film MOS is damaged.	Please contact the after-sales service center.

No.	Fault Name	Fault Cause	Fault Handling Suggestion
18	BMS1 RACK1 Heat film MOS open warning	Heating circuit is abnormal.	Please contact the after-sales service center.
19	BMS1 RACK1 Total voltage is too high fault	1. Battery system voltage is too high. 2. Voltage acquisition line is abnormal.	1. Discharge the battery and observe if the fault persists. 2. If the fault does not recover, please contact the after-sales service center.
20	BMS1 RACK1 Total voltage is too low fault	1. Battery system voltage is too low. 2. Voltage acquisition line is abnormal.	1. Charge the battery, let it rest, and observe if the fault persists. 2. Check the inverter's working condition to see if it is not charging the battery due to issues like working mode. Try charging the battery via the inverter and observe if the fault recovers. 3. If the fault does not recover, please contact the after-sales service center.
21	BMS1 RACK1 Cell voltage is too high fault	1. Single cell voltage is too high. 2. Voltage acquisition line is abnormal.	1. Discharge the battery, let it rest, and observe if the fault persists. 2. If the fault does not recover, please contact the after-sales service center.

No.	Fault Name	Fault Cause	Fault Handling Suggestion
22	BMS1 RACK1 Cell voltage is too low fault	<ol style="list-style-type: none"> 1. Single cell voltage is too low. 2. Voltage acquisition line is abnormal. 	<ol style="list-style-type: none"> 1. Charge the battery, let it rest, and observe if the fault persists. 2. Check the inverter's working condition to see if it is not charging the battery due to issues like working mode. Try charging the battery via the inverter and observe if the fault recovers. 3. If the fault does not recover, please contact the after-sales service center.
23	BMS1 RACK1 Charging temperature is too high fault	<ol style="list-style-type: none"> 1. Ambient Overtemperature 2. Temperature sensor is abnormal. 	<ol style="list-style-type: none"> 1. Place the battery in a cool place, power it off and let it rest for 30 minutes, then restart and observe if the fault persists. 2. If the fault persists, please contact the after-sales service center.

No.	Fault Name	Fault Cause	Fault Handling Suggestion
24	BMS1 RACK1 Discharging temperature is too high fault	1. Ambient Overtemperature 2. Temperature sensor is abnormal.	1. Place the battery in a cool place, power it off and let it rest for 30 minutes, then restart and observe if the fault persists. 2. If the fault persists, please contact the after-sales service center.
25	BMS1 RACK1 Charging temperature is too low fault	1. Ambient temperature is too low. 2. Temperature sensor is abnormal.	1. Check the cell temperature in the background. If the minimum temperature is above -20°C, set the battery to discharge to increase the cell temperature. 2. If the temperature is below -20°C, power off the battery and place it in a warm environment. Use it after the cell temperature rises. 3. If none of the above works, contact the after-sales service center.

No.	Fault Name	Fault Cause	Fault Handling Suggestion
26	BMS1 RACK1 Discharging temperature is too low fault	<ol style="list-style-type: none"> 1. Ambient temperature is too low. 2. Temperature sensor is abnormal. 	<ol style="list-style-type: none"> 1. Check the cell temperature in the background. If the minimum temperature is above -20°C, set the battery to discharge to increase the cell temperature. 2. If the temperature is below -20°C, power off the battery and place it in a warm environment. Use it after the cell temperature rises. 3. If none of the above works, contact the after-sales service center.
27	BMS1 RACK1 Charge overcurrent fault	<ol style="list-style-type: none"> 1. Charging current is too high, battery current limiting is abnormal: sudden changes in temperature and voltage values. 2. Inverter response is abnormal. 	<ol style="list-style-type: none"> 1. Power off and let it rest for 5 minutes, restart and observe if the fault persists. 2. Check if the inverter is set to a power output that exceeds the battery's rated operating current. 3. If overcurrent persists, contact the after-sales service center.

No.	Fault Name	Fault Cause	Fault Handling Suggestion
28	BMS1 RACK1 Discharge overcurrent fault	<ol style="list-style-type: none"> 1. Discharging current is too high, battery current limiting is abnormal: sudden changes in temperature and voltage values. 2. Inverter response is abnormal. 	<ol style="list-style-type: none"> 1. Power off and let it rest for 5 minutes, restart and observe if the fault persists. 2. Check if the inverter is set to a power output that exceeds the battery's rated operating current. 3. If overcurrent persists, contact the after-sales service center.
29	BMS1 RACK1 Insulation resistance is too low fault	Insulation resistance is damaged or contact is abnormal.	<ol style="list-style-type: none"> 1. Check if the ground wire is properly connected, restart the battery. 2. Upgrade the software. If the problem persists, please contact the after-sales service center.

No.	Fault Name	Fault Cause	Fault Handling Suggestion
30	BMS1 RACK1 Cell excessive temperature differentials fault	<ol style="list-style-type: none"> 1. At different stages of excessive temperature differential, the battery will limit the battery power, i.e., limit the charge/discharge current. Therefore, this problem is generally difficult to occur. 2. Cell capacity degradation leads to excessive internal resistance, causing large temperature rise during overcurrent, resulting in large temperature differential. 3. Poor welding of cell tabs leads to rapid cell temperature rise during overcurrent. 4. Temperature sampling issue. 5. Power line connection is loose. 	Power off, restart the battery, wait for 2 hours. If the problem is not resolved, contact the after-sales service center.

No.	Fault Name	Fault Cause	Fault Handling Suggestion
31	BMS1 RACK1 Post temperature is too high fault	Post temperature is too high.	<ol style="list-style-type: none"> 1. Power off and let it rest for 30 minutes, restart and observe if the fault persists. 2. If the fault persists, please contact the after-sales service center.
32	BMS1 RACK1 Cell excessive voltage differentials fault	<ol style="list-style-type: none"> 1. Inconsistent cell aging levels. 2. Issues with the slave board chip can also cause excessive cell voltage differential. 3. Slave board balancing issues can also cause excessive cell voltage differential. 4. Caused by wiring harness issues. 	Power off, restart the battery, wait for 2 hours. If the problem is not resolved, contact the after-sales service center.
33	BMS1 RACK1 Relay or MOS short-circuit fault	MOS short-circuit.	<ol style="list-style-type: none"> 1. Upgrade the software, power off and let it rest for 5 minutes, restart and observe if the fault persists. 2. If it persists, contact the after-sales service center.

No.	Fault Name	Fault Cause	Fault Handling Suggestion
34	BMS1 RACK1 Relay or MOS open-circuit fault	MOS open-circuit.	<ol style="list-style-type: none"> 1. Upgrade the software, power off and let it rest for 5 minutes, restart and observe if the fault persists. 2. If it persists, contact the after-sales service center.
35	BMS1 RACK1 The precharge failed fault	The voltage across the precharge MOS always exceeds the specified threshold.	<ol style="list-style-type: none"> 1. Upgrade the software, power off and let it rest for 5 minutes, restart and observe if the fault persists. 2. If it persists, contact the after-sales service center.
36	BMS1 RACK1 Acquisition line fault	Battery acquisition line has poor contact or is disconnected.	Power off, check the wiring, restack the battery. If the problem persists after restarting, please contact the after-sales service center.
37	BMS1 RACK1 Relay or MOS temperature is too high fault	Relay or MOS overtemperature.	<ol style="list-style-type: none"> 1. Upgrade the software, power off and let it rest for 30 minutes, restart and observe if the fault persists. 2. If it persists, contact the after-sales service center.

No.	Fault Name	Fault Cause	Fault Handling Suggestion
38	BMS1 RACK1 Diverter temperature is too high fault	Diverter overtemperature.	<ol style="list-style-type: none"> 1. Upgrade the software, power off and let it rest for 30 minutes, restart and observe if the fault persists. 2. If it persists, contact the after-sales service center.
39	BMS1 RACK1 Slave MCU communication fault	Communication loss between master and slave chips.	<ol style="list-style-type: none"> 1. Check the wiring, restart the battery. 2. Upgrade the battery. If the problem persists after restarting, please contact the after-sales service center.
40	BMS1 RACK1 BMU communication fault	BMS master and slave control wiring harness is abnormal.	<ol style="list-style-type: none"> 1. Check the wiring, restart the battery. 2. Upgrade the battery. If the problem persists after restarting, please contact the after-sales service center.
41	BMS1 RACK1 Micro-electronics fault	Internal MCU fault.	Upgrade the software, restart the battery. If the problem persists after restarting, please contact the after-sales service center.

No.	Fault Name	Fault Cause	Fault Handling Suggestion
42	BMS1 RACK1 Hardware overcurrent fault	1. Software version is too low or BMS board is damaged. 2. Large number of parallel inverters, causing excessive inrush current during battery precharge.	1. Upgrade the software, observe if the fault persists. 2. In case of parallel operation, start the battery with a black start first, then start the inverter.
43	BMS1 RACK1 Application software fault	MCU self-test failed.	Upgrade the software, restart the battery. If the problem persists after restarting, please contact the after-sales service center.
44	BMS1 RACK1 Parallel RACK fault	Communication abnormality between the main RACK and slave RACKs, or inconsistency of cells between RACKs.	1. Check the slave battery information and software version, and whether the communication cable connection to the master is normal. 2. Upgrade the software.
45	BMS1 RACK1 DCDC fault	DCDC overload or heat sink temperature is too high, etc.	Upgrade the software, restart the battery. If the problem persists after restarting, please contact the after-sales service center.
46	BMS1 RACK1 Inconsistent cell fault	1. Cell identification is abnormal. 2. Different types of cells are stacked.	Check the cell type.

No.	Fault Name	Fault Cause	Fault Handling Suggestion
47	BMS1 RACK1 The output port over temperature fault	Output port screws are loose or have poor contact.	1. Power off the battery, check the wiring and the condition of the output port screws. 2. After confirmation, restart the battery, observe if the fault persists. If it exists, contact the after-sales service center.
48	BMS1 RACK1 SOH too low fault	Battery has been used for too long or cells are severely damaged.	Replace the pack.
49	BMS1 RACK1 Heating film MOS Three-terminal fault	Heating film MOS is damaged.	Please contact the after-sales service center.

9 technical parameter

9.1 Inverter Parameters

Technical Data	GW5K-ETA-G20	GW6K-ETA-G20	GW8K-ETA-G20	GW9.999K-ETA-G20
Battery Side				
Battery Type	Li-Ion	Li-Ion	Li-Ion	Li-Ion
Nominal Voltage (V)	750	750	750	750
Voltage Range (V)	700-950	700-950	700-950	700-950
Start-up Voltage (V)	720	720	720	720
Number of Battery Inputs	1	1	1	1
Max. Continuous Charging Current (A)	6.7	8.1	10.7	13.4
Max. Continuous Discharging Current (A)	7.4	8.9	11.8	14.7
Max. Charging Power (kW)	5	6	8	10
Max. Discharging Power (kW)	5.5	6.6	8.8	11
PV Side				

Technical Data	GW5K-ETA-G20	GW6K-ETA-G20	GW8K-ETA-G20	GW9.999K-ETA-G20
Max. Input Power (kW)	10	12	16	20
Max. Input Voltage (V) ^{*1}	1000	1000	1000	1000
MPPT Operating Voltage Range (V) ^{*2}	120~950	120~950	120~950	120~950
MPPT Voltage Range at Nominal Power (V)	185~850	225~850	300~850	250~850
Start-up Voltage (V)	150	150	150	150
Nominal Input Voltage (V)	750	750	750	750
Max. MPPT Current (A)	21/21/21	21/21/21	21/21/21	21/21/21/21
Max. MPPT Short Circuit Current (A)	26/26/26	26/26/26	26/26/26	26/26/26/26
Number of MPPTs	3	3	3	4
Number of Strings per MPPT	1/1/1	1/1/1	1/1/1	1/1/1/1
AC Side (On-Grid)				
Rated Power (kW)	5	6	8	9.999

Technical Data	GW5K-ETA-G20	GW6K-ETA-G20	GW8K-ETA-G20	GW9.999K-ETA-G20
Max. Power (kW)	5	6	8	9.999
Rated Apparent Power to Grid (kVA)	5	6	8	9.999
Rated Apparent Power from Grid (kVA)	5	6	8	9.999
Max. Apparent Power to Grid (kVA)	5	6	8	9.999
Max. Apparent Power from Grid (kVA)	43.5	43.5	43.5	43.5
Nominal Voltage (V)	220/380, 230/400, 3L/N/PE	220/380, 230/400, 3L/N/PE	220/380, 230/400, 3L/N/PE	220/380, 230/400, 3L/N/PE
Voltage Range (V)	180 ~ 260 (According to local standard)	180 ~ 260 (According to local standard)	180 ~ 260 (According to local standard)	180 ~ 260 (According to local standard)
Nominal Frequency (Hz)	50/60	50/60	50/60	50/60
Frequency Range (Hz)	45~55 / 55~65	45~55 / 55~65	45~55 / 55~65	45~55 / 55~65
Rated Current to Grid (A)	7.6 at 380V 7.3 at 400V	9.1 at 380V 8.7 at 400V	12.2 at 380V 11.6 at 400V	15.2 at 380V 14.5 at 400V
Rated Current from Grid (A)	7.6 at 380V 7.3 at 400V	9.1 at 380V 8.7 at 400V	12.2 at 380V 11.6 at 400V	15.2 at 380V 14.5 at 400V

Technical Data	GW5K-ETA-G20	GW6K-ETA-G20	GW8K-ETA-G20	GW9.999K-ETA-G20
Max. Current to Grid (A)	7.6 at 380V 7.3 at 400V	9.1 at 380V 8.7 at 400V	12.2 at 380V 11.6 at 400V	15.2 at 380V 14.5 at 400V
Max. Current from Grid (A)	63.0	63.0	63.0	63.0
Max. Output Fault Current (Peak and Duration) (A)	46.7@4 μ s	46.7@4 μ s	46.7@4 μ s	74.6@4 μ s
Inrush Current (Peak and Duration) (A)	21.3@5ms	21.3@5ms	21.3@5ms	25.4@5ms
Power Factor	0.8 leading ... 0.8 lagging	0.8 leading ... 0.8 lagging	0.8 leading ... 0.8 lagging	0.8 leading ... 0.8 lagging
THDi	<3%	<3%	<3%	<3%
Maximum Output Overcurrent Protection (A)	46.7	46.7	46.7	74.6
Type of Voltage	a.c.	a.c.	a.c.	a.c.
Back-up Side				
Rated Output Apparent Power (kVA)	5	6	8	10
Max. Output Apparent Power (kVA)	Off-grid: 5.5 (10.0, 10s), on-grid: 43.5	Off-grid: 6.6(12, 10s), on-grid: 43.5	Off-grid: 8.8 (16.0, 10s), on-grid: 43.5	Off-grid: 11(20.0, 10s), on-grid: 43.5

Technical Data	GW5K-ETA-G20	GW6K-ETA-G20	GW8K-ETA-G20	GW9.999K-ETA-G20
Nominal Output Voltage (V)	220/380, 230/400, 3L/N/PE	220/380, 230/400, 3L/N/PE	220/380, 230/400, 3L/N/PE	220/380, 230/400, 3L/N/PE
Nominal Output Frequency (Hz)	50/60	50/60	50/60	50/60
Frequency Range (Hz)	45~55 / 55~65	45~55 / 55~65	45~55 / 55~65	45~55 / 55~65
Rated Output Current (A)	7.6 at 380V 7.3 at 400V	9.1 at 380V 8.7 at 400V	12.2 at 380V 11.6 at 400V	15.2 at 380V 14.5 at 400V
Max. Output Current (A)*3	Off-grid: 11.4, on-grid: 63	Off-grid: 13.7, on-grid:63	Off-grid: 18.2, on-grid: 63	Off-grid: 22.8, on-grid:63
Max. Output Fault Current (Peak and Duration) (A)	46.7@4μs	46.7@4μs	46.7@4μs	74.6@4μs
Inrush Current (Peak and Duration) (A)	21.3@5ms	21.3@5ms	21.3@5ms	25.4@5ms
Maximum Overcurrent Protection (A)	46.7	46.7	46.7	74.6
THDv (@Linear Load)	<3%	<3%	<3%	<3%
On/Off-grid Switching Time (ms)	<4	<4	<4	<4
Efficiency				
Max. Efficiency	98.00%	98.00%	98.00%	98.10%

Technical Data	GW5K-ETA-G20	GW6K-ETA-G20	GW8K-ETA-G20	GW9.999K-ETA-G20
European Efficiency	96.40%	96.90%	97.10%	97.20%
Max. Battery to AC Efficiency	98.00%	98.00%	98.00%	98.00%
Protection				
PV String Current Monitoring	Integrated	Integrated	Integrated	Integrated
PV Insulation Resistance Detection	Integrated	Integrated	Integrated	Integrated
Residual Current Monitoring	Integrated	Integrated	Integrated	Integrated
PV Reverse Polarity Protection	Integrated	Integrated	Integrated	Integrated
Battery Reverse Polarity Protection	Integrated	Integrated	Integrated	Integrated
Anti-islanding Protection	Integrated	Integrated	Integrated	Integrated
AC Overcurrent Protection	Integrated	Integrated	Integrated	Integrated
AC Short Circuit Protection	Integrated	Integrated	Integrated	Integrated

Technical Data	GW5K-ETA-G20	GW6K-ETA-G20	GW8K-ETA-G20	GW9.999K-ETA-G20
AC Overvoltage Protection	Integrated	Integrated	Integrated	Integrated
DC Switch	Integrated	Integrated	Integrated	Integrated
DC Surge Protection	Type II(Type I+II optional)	Type II(Type I+II optional)	Type II(Type I+II optional)	Type II(Type I+II optional)
AC Surge Protection	Type II	Type II	Type II	Type II
Rapid Shutdown	Optional	Optional	Optional	Optional
AFCI	Optional	Optional	Optional	Optional
Remote Shutdown	Integrated	Integrated	Integrated	Integrated
General Data				
Operating Temperature Range (°C)	-35~+60	-35~+60	-35~+60	-35~+60
Operating Environment	Indoor/Outdoor	Indoor/Outdoor	Indoor/Outdoor	Indoor/Outdoor
Relative Humidity	0~100%	0~100%	0~100%	0~100%
Max. Operating Altitude (m)	4000 (>2000 derating)	4000 (>2000 derating)	4000 (>2000 derating)	4000 (>2000 derating)
Cooling Method	Smart Fan Cooling	Smart Fan Cooling	Smart Fan Cooling	Smart Fan Cooling
User Interface	LED, WLAN+APP	LED, WLAN+APP	LED, WLAN+APP	LED, WLAN+APP

Technical Data	GW5K-ETA-G20	GW6K-ETA-G20	GW8K-ETA-G20	GW9.999K-ETA-G20
Communication with BMS	CAN	CAN	CAN	CAN
Communication	RS485, WiFi+LAN+Bluetooth, 4G+Bluetooth(Optional)	RS485, WiFi+LAN+Bluetooth, 4G+Bluetooth(Optional)	RS485, WiFi+LAN+Bluetooth, 4G+Bluetooth(Optional)	RS485, WiFi+LAN+Bluetooth, 4G+Bluetooth(Optional)
Communication Protocols	Modbus-RTU, Modbus-TCP	Modbus-RTU, Modbus-TCP	Modbus-RTU, Modbus-TCP	Modbus-RTU, Modbus-TCP
Weight (kg)	34	34	34	34
Dimension (W×H×D mm)	800*340*270	800*340*270	800*340*270	800*340*270
Noise Emission (dB)	≤35	≤35	≤35	≤40
Topology	Non-isolated	Non-isolated	Non-isolated	Non-isolated
Self-consumption at Night (W)	≤10	≤10	≤10	≤10
Ingress Protection Rating	IP66	IP66	IP66	IP66
DC Connector	MC4, VACONN Terminal	MC4, VACONN Terminal	MC4, VACONN Terminal	MC4, VACONN Terminal
AC Connector	VACONN Terminal	VACONN Terminal	VACONN Terminal	VACONN Terminal
Environmental Category	4K4H	4K4H	4K4H	4K4H

Technical Data	GW5K-ETA-G20	GW6K-ETA-G20	GW8K-ETA-G20	GW9.999K-ETA-G20
Pollution Degree	IV	IV	IV	IV
Overvoltage Category	DC II / AC III	DC II / AC III	DC II / AC III	DC II / AC III
Protective Class	I	I	I	I
Storage Temperature (°C)	-40~+70	-40~+70	-40~+70	-40~+70
The Decisive Voltage Class (DVC)	Battery: C	Battery: C	Battery: C	Battery: C
	PV: C	PV: C	PV: C	PV: C
	AC: C	AC: C	AC: C	AC: C
	Com: A	Com: A	Com: A	Com: A
Mounting Method	Wall/Floor Mounted	Wall/Floor Mounted	Wall/Floor Mounted	Wall/Floor Mounted
Active Anti-islanding Method	SMS(Slip-mode frequency) +AFD ^{*4}	SMS(Slip-mode frequency) +AFD ^{*4}	SMS(Slip-mode frequency) +AFD ^{*4}	SMS(Slip-mode frequency) +AFD ^{*4}
Type of Electrical Supply System	three phase	three phase	three phase	three phase
Country of Manufacture	China	China	China	China
Certification				
Grid Standard	Please refer to the official website			
Safety Regulation				

Technical Data	GW5K-ETA-G20	GW6K-ETA-G20	GW8K-ETA-G20	GW9.999K-ETA-G20
EMC				

Technical Data	GW10K-ETA-G20	GW12K-ETA-G20	GW15K-ETA-G20	GW20K-ETA-G20
Battery Side				
Battery Type	Li-Ion	Li-Ion	Li-Ion	Li-Ion
Nominal Voltage (V)	750	750	750	750
Voltage Range (V)	700-950	700-950	700-950	700-950
Start-up Voltage (V) ^{*1}	720	720	720	720
Number of Battery Inputs	1	1	1	1
Max. Continuous Charging Current (A)	13.4	16.1	20.1	26.7
Max. Continuous Discharging Current (A)	14.7	17.7	22.1	29.4
Max. Charging Power (kW)	10	12	15	20
Max. Discharging Power (kW)	11	13.2	16.5	22
PV Side				

Technical Data	GW10K-ETA-G20	GW12K-ETA-G20	GW15K-ETA-G20	GW20K-ETA-G20
Max. Input Power (kW)	20	24	30	40
Max. Input Voltage (V) ^{*1}	1000	1000	1000	1000
MPPT Operating Voltage Range (V) ^{*2}	120~950	120~950	120~950	120~950
MPPT Voltage Range at Nominal Power (V)	250~850	300~850	360~850	400~850
Start-up Voltage (V)	150	150	150	150
Nominal Input Voltage (V)	750	750	750	750
Max. MPPT Current (A)	21/21/21/21	21/21/21/21	21/21/21/21	21/21/21/21
Max. MPPT Short Circuit Current (A)	26/26/26/26	26/26/26/26	26/26/26/26	26/26/26/26
Number of MPPTs	4	4	4	4
Number of Strings per MPPT	1/1/1/1	1/1/1/1	1/1/1/1	1/1/1/1
AC Side (On-Grid)				
Rated Power (kW)	10	12	15	20

Technical Data	GW10K-ETA-G20	GW12K-ETA-G20	GW15K-ETA-G20	GW20K-ETA-G20
Max. Power (kW)	10	12	15	20
Rated Apparent Power to Grid (kVA)	10	12	15	20
Rated Apparent Power from Grid (kVA)	10	12	15	20
Max. Apparent Power to Grid (kVA)	10	12	15	20
Max. Apparent Power from Grid (kVA)	43.5	43.5	43.5	43.5
Nominal Voltage (V)	220/380, 230/400, 3L/N/PE	220/380, 230/400, 3L/N/PE	220/380, 230/400, 3L/N/PE	220/380, 230/400, 3L/N/PE
Voltage Range (V)	180 ~ 260 (According to local standard)	180 ~ 260 (According to local standard)	180 ~ 260 (According to local standard)	180 ~ 260 (According to local standard)
Nominal Frequency (Hz)	50/60	50/60	50/60	50/60
Frequency Range (Hz)	45~55 / 55~65	45~55 / 55~65	45~55 / 55~65	45~55 / 55~65
Rated Current to Grid (A)	15.2 at 380V 14.5 at 400V	18.2 at 380V 17.4 at 400V	22.8 at 380V 21.8 at 400V	30.4 at 380V 29.0 at 400V
Rated Current from Grid (A)	15.2 at 380V 14.5 at 400V	18.2 at 380V 17.4 at 400V	22.8 at 380V 21.8 at 400V	30.4 at 380V 29.0 at 400V

Technical Data	GW10K-ETA-G20	GW12K-ETA-G20	GW15K-ETA-G20	GW20K-ETA-G20
Max. Current to Grid (A)	15.2 at 380V 14.5 at 400V	18.2 at 380V 17.4 at 400V	22.8 at 380V 21.8 at 400V	30.4 at 380V 29.0 at 400V
Max. Current from Grid (A)	63.0	63.0	63.0	63.0
Max. Output Fault Current (Peak and Duration) (A)	74.6@4 μ s	74.6@4 μ s	83.3@4 μ s	83.3@4 μ s
Inrush Current (Peak and Duration) (A)	25.4@5ms	25.4@5ms	29.1@5ms	29.1@5ms
Power Factor	0.8 leading ... 0.8 lagging	0.8 leading ... 0.8 lagging	0.8 leading ... 0.8 lagging	0.8 leading ... 0.8 lagging
THDi	<3%	<3%	<3%	<3%
Maximum Output Overcurrent Protection (A)	74.6	74.6	83.3	83.3
Type of Voltage	a.c.	a.c.	a.c.	a.c.
Back-up Side				
Rated Output Apparent Power (kVA)	10	12	15	20
Max. Output Apparent Power (kVA)	Off-grid: 11(20.0, 10s), on-grid: 43.5	Off-grid: 13.2(24, 10s), on-grid: 43.5	Off-grid: 16.5(30, 10s), on-grid:43.5	Off-grid: 22(30.0, 10s), on-grid:43.5

Technical Data	GW10K-ETA-G20	GW12K-ETA-G20	GW15K-ETA-G20	GW20K-ETA-G20
Nominal Output Voltage (V)	220/380, 230/400, 3L/N/PE	220/380, 230/400, 3L/N/PE	220/380, 230/400, 3L/N/PE	220/380, 230/400, 3L/N/PE
Nominal Output Frequency (Hz)	50/60	50/60	50/60	50/60
Frequency Range (Hz)	45~55 / 55~65	45~55 / 55~65	45~55 / 55~65	45~55 / 55~65
Rated Output Current (A)	15.2 at 380V 14.5 at 400V	18.2 at 380V 17.4 at 400V	22.8 at 380V 21.8 at 400V	30.4 at 380V 29.0 at 400V
Max. Output Current (A)*3	Off-grid: 22.8, on-grid: 63	Off-grid: 27.3, on-grid: 63	Off-grid: 33.4, on-grid: 63	Off-grid: 33.4, on-grid: 63
Max. Output Fault Current (Peak and Duration) (A)	74.6@4μs	74.6@4μs	83.3@4μs	83.3@4μs
Inrush Current (Peak and Duration) (A)	25.4@5ms	25.4@5ms	29.1@5ms	29.1@5ms
Maximum Overcurrent Protection (A)	74.6	74.6	83.3	83.3
THDv (@Linear Load)	<3%	<3%	<3%	<3%
On/Off-grid Switching Time (ms)	<4	<4	<4	<4
Efficiency				
Max. Efficiency	98.10%	98.10%	98.10%	98.10%

Technical Data	GW10K-ETA-G20	GW12K-ETA-G20	GW15K-ETA-G20	GW20K-ETA-G20
European Efficiency	97.20%	97.20%	97.30%	97.30%
Max. Battery to AC Efficiency	98.00%	98.00%	98.00%	98.00%
Protection				
PV String Current Monitoring	Integrated	Integrated	Integrated	Integrated
PV Insulation Resistance Detection	Integrated	Integrated	Integrated	Integrated
Residual Current Monitoring	Integrated	Integrated	Integrated	Integrated
PV Reverse Polarity Protection	Integrated	Integrated	Integrated	Integrated
Battery Reverse Polarity Protection	Integrated	Integrated	Integrated	Integrated
Anti-islanding Protection	Integrated	Integrated	Integrated	Integrated
AC Overcurrent Protection	Integrated	Integrated	Integrated	Integrated
AC Short Circuit Protection	Integrated	Integrated	Integrated	Integrated

Technical Data	GW10K-ETA-G20	GW12K-ETA-G20	GW15K-ETA-G20	GW20K-ETA-G20
AC Overvoltage Protection	Integrated	Integrated	Integrated	Integrated
DC Switch	Integrated	Integrated	Integrated	Integrated
DC Surge Protection	Type II(Type I+II optional)	Type II(Type I+II optional)	Type II(Type I+II optional)	Type II(Type I+II optional)
AC Surge Protection	Type II	Type II	Type II	Type II
Rapid Shutdown	Optional	Optional	Optional	Optional
AFCI	Optional	Optional	Optional	Optional
Remote Shutdown	Integrated	Integrated	Integrated	Integrated
General Data				
Operating Temperature Range (°C)	-35~+60	-35~+60	-35~+60	-35~+60
Operating Environment	Indoor/Outdoor	Indoor/Outdoor	Indoor/Outdoor	Indoor/Outdoor
Relative Humidity	0~100%	0~100%	0~100%	0~100%
Max. Operating Altitude (m)	4000 (>2000 derating)	4000 (>2000 derating)	4000 (>2000 derating)	4000 (>2000 derating)
Cooling Method	Smart Fan Cooling	Smart Fan Cooling	Smart Fan Cooling	Smart Fan Cooling
User Interface	LED, WLAN+APP	LED, WLAN+APP	LED, WLAN+APP	LED, WLAN+APP

Technical Data	GW10K-ETA-G20	GW12K-ETA-G20	GW15K-ETA-G20	GW20K-ETA-G20
Communication with BMS	CAN	CAN	CAN	CAN
Communication	RS485, WiFi+LAN+Bluetooth, 4G+Bluetooth(Optional)	RS485, WiFi+LAN+Bluetooth, 4G+Bluetooth(Optional)	RS485, WiFi+LAN+Bluetooth, 4G+Bluetooth(Optional)	RS485, WiFi+LAN+Bluetooth, 4G+Bluetooth(Optional)
Communication Protocols	Modbus-RTU, Modbus-TCP	Modbus-RTU, Modbus-TCP	Modbus-RTU, Modbus-TCP	Modbus-RTU, Modbus-TCP
Weight (kg)	34	34	34	34
Dimension (W×H×D mm)	800*340*270	800*340*270	800*340*270	800*340*270
Noise Emission (dB)	≤40	≤40	≤40	≤40
Topology	Non-isolated	Non-isolated	Non-isolated	Non-isolated
Self-consumption at Night (W)	≤10	≤10	≤10	≤10
Ingress Protection Rating	IP66	IP66	IP66	IP66
DC Connector	MC4, VACONN Terminal	MC4, VACONN Terminal	MC4, VACONN Terminal	MC4, VACONN Terminal
AC Connector	VACONN Terminal	VACONN Terminal	VACONN Terminal	VACONN Terminal
Environmental Category	4K4H	4K4H	4K4H	4K4H

Technical Data	GW10K-ETA-G20	GW12K-ETA-G20	GW15K-ETA-G20	GW20K-ETA-G20
Pollution Degree	IV	IV	IV	IV
Overvoltage Category	DC II / AC III	DC II / AC III	DC II / AC III	DC II / AC III
Protective Class	I	I	I	I
Storage Temperature (°C)	-40~+70	-40~+70	-40~+70	-40~+70
The Decisive Voltage Class (DVC)	Battery: C	Battery: C	Battery: C	Battery: C
	PV: C	PV: C	PV: C	PV: C
	AC: C	AC: C	AC: C	AC: C
	Com: A	Com: A	Com: A	Com: A
Mounting Method	Wall/Floor Mounted	Wall/Floor Mounted	Wall/Floor Mounted	Wall/Floor Mounted
Active Anti-islanding Method	SMS(Slip-mode frequency) +AFD ^{*4}	SMS(Slip-mode frequency) +AFD ^{*4}	SMS(Slip-mode frequency) +AFD ^{*4}	SMS(Slip-mode frequency) +AFD ^{*4}
Type of Electrical Supply System	three phase	three phase	three phase	three phase
Country of Manufacture	China	China	China	China
Certification				
Grid Standard	Please refer to the official website			
Safety Regulation				

Technical Data	GW10K-ETA-G20	GW12K-ETA-G20	GW15K-ETA-G20	GW20K-ETA-G20
EMC				

Technical Data	GW25K-ETA-G20	GW29.999K-ETA-G20	GW30K-ETA-G20
Battery Side			
Battery Type	Li-Ion	Li-Ion	Li-Ion
Nominal Voltage (V)	750	750	750
Voltage Range (V)	700-950	700-950	700-950
Start-up Voltage (V)	720	720	720
Number of Battery Inputs	1	1	1
Max. Continuous Charging Current (A)	33.3	40.0	40.0
Max. Continuous Discharging Current (A)	36.7	44.1	44.1
Max. Charging Power (kW)	25	30	30
Max. Discharging Power (kW)	27.5	33	33
PV Side			
Max. Input Power (kW)	50	60	60
Max. Input Voltage (V)*1	1000	1000	1000

Technical Data	GW25K-ETA-G20	GW29.999K-ETA-G20	GW30K-ETA-G20
MPPT Operating Voltage Range (V) ^{*2}	120~950	120~950	120~950
MPPT Voltage Range at Nominal Power (V)	400~850	450~850	450~850
Start-up Voltage (V)	150	150	150
Nominal Input Voltage (V)	750	750	750
Max. MPPT Current (A)	21/21/42/42	21/21/42/42	21/21/42/42
Max. MPPT Short Circuit Current (A)	26/26/52/52	26/26/52/52	26/26/52/52
Number of MPPTs	4	4	4
Number of Strings per MPPT	1/1/2/2	1/1/2/2	1/1/2/2
AC Side (On-Grid)			
Rated Power (kW)	25	29.999	30
Max. Power (kW)	25	29.999	30
Rated Apparent Power to Grid (kVA)	25	29.999	30
Rated Apparent Power from Grid (kVA)	25	29.999	30
Max. Apparent Power to Grid (kVA)	25	29.999	30

Technical Data	GW25K-ETA-G20	GW29.999K-ETA-G20	GW30K-ETA-G20
Max. Apparent Power from Grid (kVA)	55.2	55.2	55.2
Nominal Voltage (V)	220/380, 230/400, 3L/N/PE	220/380, 230/400, 3L/N/PE	220/380, 230/400, 3L/N/PE
Voltage Range (V)	180 ~ 260 (According to local standard)	180 ~ 260 (According to local standard)	180 ~ 260 (According to local standard)
Nominal Frequency (Hz)	50/60	50/60	50/60
Frequency Range (Hz)	45~55 / 55~65	45~55 / 55~65	45~55 / 55~65
Rated Current to Grid (A)	37.9 at 380V 36.3 at 400V	45.5 at 380V 43.5 at 400V	45.5 at 380V 43.5 at 400V
Rated Current from Grid (A)	37.9 at 380V 36.3 at 400V	45.5 at 380V 43.5 at 400V	45.5 at 380V 43.5 at 400V
Max. Current to Grid (A)	37.9 at 380V 36.3 at 400V	45.5 at 380V 43.5 at 400V	45.5 at 380V 43.5 at 400V
Max. Current from Grid (A)	80.0	80.0	80.0
Max. Output Fault Current (Peak and Duration) (A)	125@4 μ s	125@4 μ s	125@4 μ s
Inrush Current (Peak and Duration) (A)	32.3@5ms	32.3@5ms	32.3@5ms
Power Factor	0.8 leading ... 0.8 lagging	0.8 leading ... 0.8 lagging	0.8 leading ... 0.8 lagging

Technical Data	GW25K-ETA-G20	GW29.999K-ETA-G20	GW30K-ETA-G20
THDi	<3%	<3%	<3%
Maximum Output Overcurrent Protection (A)	125	125	125
Type of Voltage	a.c.	a.c.	a.c.
Back-up Side			
Rated Output Apparent Power (kVA)	25	30	30
Max. Output Apparent Power (kVA)	Off-grid: 27.5(45.0, 10s), on-grid:55.2	Off-grid: 33(45.0, 10s), on-grid: 55.2	Off-grid: 33(45.0, 10s), on-grid:55.2
Nominal Output Voltage (V)	220/380, 230/400, 3L/N/PE	220/380, 230/400, 3L/N/PE	220/380, 230/400, 3L/N/PE
Nominal Output Frequency (Hz)	50/60	50/60	50/60
Frequency Range (Hz)	45~55 / 55~65	45~55 / 55~65	45~55 / 55~65
Rated Output Current (A)	37.9 at 380V 36.3 at 400V	45.5 at 380V 43.5 at 400V	45.5 at 380V 43.5 at 400V
Max. Output Current (A) ^{*3}	Off-grid: 50.0, on-grid: 80	Off-grid: 50.0, on-grid: 80	Off-grid: 50.0, on-grid: 80
Max. Output Fault Current (Peak and Duration) (A)	125@4μs	125@4μs	125@4μs
Inrush Current (Peak and Duration) (A)	32.3@5ms	32.3@5ms	32.3@5ms

Technical Data	GW25K-ETA-G20	GW29.999K-ETA-G20	GW30K-ETA-G20
Maximum Overcurrent Protection (A)	125	125	125
THDv (@Linear Load)	<3%	<3%	<3%
On/Off-grid Switching Time (ms)	<4	<4	<4
Efficiency			
Max. Efficiency	98.20%	98.20%	98.20%
European Efficiency	97.40%	97.40%	97.40%
Max. Battery to AC Efficiency	98.00%	98.00%	98.00%
Protection			
PV String Current Monitoring	Integrated	Integrated	Integrated
PV Insulation Resistance Detection	Integrated	Integrated	Integrated
Residual Current Monitoring	Integrated	Integrated	Integrated
PV Reverse Polarity Protection	Integrated	Integrated	Integrated
Battery Reverse Polarity Protection	Integrated	Integrated	Integrated
Anti-islanding Protection	Integrated	Integrated	Integrated

Technical Data	GW25K-ETA-G20	GW29.999K-ETA-G20	GW30K-ETA-G20
AC Overcurrent Protection	Integrated	Integrated	Integrated
AC Short Circuit Protection	Integrated	Integrated	Integrated
AC Overvoltage Protection	Integrated	Integrated	Integrated
DC Switch	Integrated	Integrated	Integrated
DC Surge Protection	Type II(Type I+II optional)	Type II(Type I+II optional)	Type II(Type I+II optional)
AC Surge Protection	Type II	Type II	Type II
Rapid Shutdown	Optional	Optional	Optional
AFCI	Optional	Optional	Optional
Remote Shutdown	Integrated	Integrated	Integrated
General Data			
Operating Temperature Range (°C)	-35~+60	-35~+60	-35~+60
Operating Environment	Indoor/Outdoor	Indoor/Outdoor	Indoor/Outdoor
Relative Humidity	0~100%	0~100%	0~100%
Max. Operating Altitude (m)	4000 (>2000 derating)	4000 (>2000 derating)	4000 (>2000 derating)
Cooling Method	Smart Fan Cooling	Smart Fan Cooling	Smart Fan Cooling
User Interface	LED, WLAN+APP	LED, WLAN+APP	LED, WLAN+APP

Technical Data	GW25K-ETA-G20	GW29.999K-ETA-G20	GW30K-ETA-G20
Communication with BMS	CAN	CAN	CAN
Communication	RS485, WiFi+LAN+Bluetooth, 4G+Bluetooth(Optional)	RS485, WiFi+LAN+Bluetooth, 4G+Bluetooth(Optional)	RS485, WiFi+LAN+Bluetooth, 4G+Bluetooth(Optional)
Communication Protocols	Modbus-RTU, Modbus-TCP	Modbus-RTU, Modbus-TCP	Modbus-RTU, Modbus-TCP
Weight (kg)	38	38	38
Dimension (W×H×D mm)	800*340*270	800*340*270	800*340*270
Noise Emission (dB)	≤45	≤45	≤45
Topology	Non-isolated	Non-isolated	Non-isolated
Self-consumption at Night (W)	≤10	≤10	≤10
Ingress Protection Rating	IP66	IP66	IP66
DC Connector	MC4, VACONN Terminal	MC4, VACONN Terminal	MC4, VACONN Terminal
AC Connector	VACONN Terminal	VACONN Terminal	VACONN Terminal
Environmental Category	4K4H	4K4H	4K4H
Pollution Degree	IV	IV	IV
Overvoltage Category	DC II / AC III	DC II / AC III	DC II / AC III

Technical Data	GW25K-ETA-G20	GW29.999K-ETA-G20	GW30K-ETA-G20
Protective Class	I	I	I
Storage Temperature (°C)	-40~+70	-40~+70	-40~+70
The Decisive Voltage Class (DVC)	Battery: C	Battery: C	Battery: C
	PV: C	PV: C	PV: C
	AC: C	AC: C	AC: C
	Com: A	Com: A	Com: A
Mounting Method	Wall/Floor Mounted	Wall/Floor Mounted	Wall/Floor Mounted
Active Anti-islanding Method	SMS(Slip-mode frequency) +AFD ^{*4}	SMS(Slip-mode frequency) +AFD ^{*4}	SMS(Slip-mode frequency) +AFD ^{*4}
Type of Electrical Supply System	three phase	three phase	three phase
Country of Manufacture	China	China	China
Certification			
Grid Standard	Please refer to the official website		
Safety Regulation			
EMC			

*1: When the input voltage ranges from 950V to 1000V, the inverter will enter the standby mode, and the voltage returns to 950V to enter the normal operation state.

*2: Please refer to the user manual for the MPPT Voltage Range at nominal Power.

*3: The Max. Output Current in off-grid operation accounts for a three-phase maximum 150% unbalanced capability.

*4: AFDPF: Active Frequency Drift with Positive Feedback, AQDPF: Active Q Drift with Positive Feedback.

9.2 Battery Technical Data

Technical Data	GW5.1-BAT-D-G20	GW8.3-BAT-D-G20	GW5.1-BAT-D-G21	GW8.3-BAT-D-G21
Rated Energy (kWh)	5.12	8.32	5.12	8.32
Usable Energy (kWh)*1	5	8	5	8
Battery Type	LFP (LiFePO ₄)			
Operating Voltage Range (V) (single phase system)	350~550			
Operating Voltage Range (V) (three phase system)	700~950			
Max. Input Current (System) (A)	12	19	12	19
Max. Output Current (System) (A)	13.2	21	13.2	21
Max. Input Power (System) (kW)*2	5	8	5	8
Max. Output Power (System) (kW)*2	5	8	5	8
Peak.Output Power (System) (kW)*2	7.5 @10s	12 @10s	7.5 @10s	12 @10s
Charging Temperature Range (°C)	-18~55		2~55	
Discharging Temperature Range (°C)	-20~55		-20~55	
Relative Humidity	5-95%			
Max. Operating Altitude (m)	4000			

Technical Data		GW5.1-BAT-D-G20	GW8.3-BAT-D-G20	GW5.1-BAT-D-G21	GW8.3-BAT-D-G21
Noise Emission (dB)		≤29			
Communication		CAN			
Weight (kg)		57.5±1	79±1	57.5±1	79±1
Dimensions (W×H×D mm)		800*326*270			
Optional Function Configuration		heating		/	
Ingress Protection		IP66			
Storage Temperature (°C)		-20 ~55			
Max. Storage time		12 months (-20°C~35°C)			
		6 months (35°C~45°C)			
Scalability		6 pcs			
Mounting Method		Floor stacked / Wall-mounted			
Cycle Life		≥6000 (25±2°C, 0.5C, 90%DOD, 70%EOL)			
Country of Manufacture		China			
Standard and Certification	Safety	IEC62619, IEC60730, EN62477, IEC63056, IEC62040, CE, CEC, VDE2510			
	EMC	CE, RCM			
	Transportation	UN38.3 ADR			

*1: Test conditions, 100% DOD (cell 2.85~3.6V voltage range), 0.2P charge & discharge at 25±2 °C for battery system at the beginning of life. Usable energy is defined by its initial design value. Actual available energy may vary depending on charge/discharge rate, environmental conditions (e.g. temperature), transport and storage factors.

*2: Max. Input Power /Max. Output Power/Peak.Output Power derating will occur related to Temperature and SOC.

9.3 Smart Meter Technical Data

9.3.1 GM330

technical parameter		GM330
Measurement Range	Supported Grid Type	Three-phase, Split-phase, Single-phase
	voltage range L-L (Vac)	172~817
	voltage range L-N (Vac)	100~472
	Nominal Frequency (Hz)	50/60
	CT ratio	nA:5A
Communication Parameters	Communication Method	RS485
	Communication Distance (m/ft)	1000/3280
Accuracy Parameters	voltage/current	Class 0.5
	Active Energy	Class 0.5
	Reactive Energy	Class 1
General Parameters	Dimensions (WxHxD mm/in)	72x85x72/2.83x3.35x2.83
	Housing	4-module
	Weight (g/lb)	240/0.53
	Mounting Method	DIN Rail
	User Interface	4 LEDs, Reset Button
	Power Consumption (W)	≤5
Environmental Parameters	IP Rating	IP20
	Operating Temperature Range (°C/°F)	-30~+70/-22~+158
	Storage Temperature Range (°C/°F)	-30~70/-22~+158
	Relative Humidity (non-condensing)	0~95%

technical parameter		GM330
	Max. Operating Altitude (m/ft)	3000/9842
Certification Parameters	Certificates	UL1741/ANSI

9.3.2 GMK330

model	GMK330
Measurement Range	
Supported Grid Types	1P2W/3P3W/3P4W
Operating voltage (Vac)*	3P4W: 90~264 L-N 3P3W: 90~264 L-L
Frequency (Hz)	50/60
CT ratio	120A: 40mA 200A: 50mA*
Number of CTs	3
Accuracy Parameters	
voltage/current	Class 0.5
Active Energy	Class 0.5
Reactive Energy	Class 1
Communication Parameters	
Communication Method	RS485
Communication Distance (m)	1000
General Parameters	
Dimensions (W*H*D mm)	72*85*72
Housing	4-module

model	GMK330
Weight (g)	240
Mounting Method	DIN Rail
User Interface	4 LEDs, Reset Button
Power Consumption (W)	< 5
Environmental Parameters	
IP Rating	IP20
Operating Temperature Range (°C)	-30-+70
Storage Temperature Range (°C)	-30-+70
Relative Humidity (non-condensing)	0-95%
Max. Operating Altitude (m)	3000

*Supports 1.1 times rated voltage connection.

*The standard CT for the meter has been uniformly changed to the 120A:40mA specification. Meters equipped with CTs of the 200A:50mA specification will no longer be sold after June 2026.

9.4 Smart Dongle Technical Data

9.4.1 WiFi/LAN Kit-20

technical parameter		WiFi/LAN Kit-20
Output Voltage (V)		5
Power Consumption (W)		≤2
Communication Interface		USB
Communication Parameters	Ethernet	10M/100Mbps Auto-negotiation
	Wireless	IEEE 802.11 b/g/n @2.4 GHz
	Bluetooth	Bluetooth V4.2 BR/EDR and Bluetooth LE Standard

technical parameter		WiFi/LAN Kit-20
Mechanical Parameters	Dimensions (W×H×D mm)	48.3*159.5*32.1
	Weight (g)	82
	Ingress Protection Rating	IP65
	Mounting Method	USB Port Plug and Play
Operating Temperature Range (°C)		-30~+60
Storage Temperature Range (°C)		-40~+70
Relative Humidity		0-95%
Max. Operating Altitude (m)		4000

10 Appendix

10.1 FAQ

10.1.1 How to conduct auxiliary detection for smart meters/CT?

The meter detection function can detect whether the meter CT is connected correctly and the current operating status of the meter and CT.

1. Navigate to the detection page via **[Home]** > **[Settings]** > **[Meter/CT Auxiliary Detection]**.
2. Click Start Detection, wait for the detection to complete, and then view the detection results.

10.1.2 How to Upgrade the Device Version

Through firmware information, you can view or upgrade:

The inverter's DSP version, ARM version, communication module software version, battery's BMS version, DCDC version, etc.

- **Prompt Upgrade:**

When the user opens the App, an upgrade prompt pops up on the home page. The user can choose whether to upgrade. If they choose to upgrade, they can complete the upgrade by following the on-screen instructions.

- **Regular Upgrade:**

Go to **[Home]** > **[Settings]** > **[Firmware Information]** to enter the firmware information viewing interface.

Click "Check for Updates". If a new version is available, complete the upgrade by following the on-screen instructions.

- **Forced Upgrade:**

The App pushes upgrade information. The user must upgrade according to the prompts; otherwise, the App cannot be used. Complete the upgrade by following the

on-screen instructions.

Inverter Software Version Upgrade

- The inverter supports software upgrade via a USB drive.
- Before using a USB drive to upgrade the device, please contact the after-sales service center to obtain the software upgrade package and upgrade method.

10.2 Abbreviations

Abbreviation	English Description	Chinese Description
Ubatt	Battery Voltage Range	Battery voltage range
Ubatt,r	Nominal Battery Voltage	Nominal battery voltage
Ibatt,max (C/D)	Max. Charging Current Max. Discharging Current	Max. charging/discharging current
EC,R	Rated Energy	Rated energy
UDCmax	Max.Input Voltage	Max. Input Voltage
UMPP	MPPT Operating Voltage Range	MPPT voltage range
IDC,max	Max. Input Current per MPPT	Max. input current per MPPT string
ISC PV	Max. Short Circuit Current per MPPT	Max. short-circuit current per MPPT string
PAC,r	Nominal Output Power	Nominal output power
Sr (to grid)	Nominal Apparent Power Output to Utility Grid	Nominal Apparent Power Output to Utility Grid
Smax (to grid)	Max. Apparent Power Output to Utility Grid	Max. Apparent Power Output to Utility Grid
Sr (from grid)	Nominal Apparent Power from Utility Grid	Nominal apparent power purchased from utility grid
Smax (from grid)	Max. Apparent Power from Utility Grid	Max. apparent power purchased from utility grid
UAC,r	Nominal Output Voltage	Nominal output voltage
fAC,r	Nominal AC Grid Frequency	Nominal AC Grid Frequency
IAC,max(to grid)	Max. AC Current Output to Utility Grid	Max. AC Current Output to Utility Grid
IAC,max(from grid)	Max. AC Current From Utility Grid	Max. Current from Grid

Abbreviation	English Description	Chinese Description
P.F.	Power Factor	Power Factor
Sr	Back-up Nominal apparent power	Off-grid nominal apparent power
Smax	Max. Output Apparent Power (VA) Max. Output Apparent Power without Grid	Max. Apparent Power to Grid
IAC,max	Max. Output Current	Max. Current to Grid
UAC,r	Nominal Output Voltage	Max. output voltage
fAC,r	Nominal Output Frequency	Nominal output voltage frequency
Toperating	Operating Temperature Range	Operating Temperature Range
IDC,max	Max. Input Current	Max. input current
UDC	Input Voltage	Input voltage
UDC,r	DC Power Supply	DC input
UAC	Power Supply/AC Power Supply	Input voltage range/AC input
UAC,r	Power Supply/Input Voltage Range	Input voltage range/AC input
Toperating	Operating Temperature Range	Operating Temperature Range
Pmax	Max Output Power	Maximum Power
PRF	TX Power	Transmit power
PD	Power Consumption	Power consumption
PAC,r	Power Consumption	Power consumption
F (Hz)	Frequency	Frequency
ISC PV	Max. Input Short Circuit Current	Max. input short-circuit current
Udcmin-Udcmax	Range of input Operating Voltage	Operating Voltage range
UAC,rang(L-N)	Power Supply Input Voltage	Adapter input voltage range
U _{sys,max}	Max System Voltage	Max. system voltage
Haltitude,max	Max. Operating Altitude	Max. operating altitude
PF	Power Factor	Power Factor
THDi	Total Harmonic Distortion of Current	Current harmonic distortion

Abbreviation	English Description	Chinese Description
THDv	Total Harmonic Distortion of Voltage	Voltage harmonic distortion
C&I	Commercial & Industrial	Commercial & Industrial
SEMS	Smart Energy Management System	Smart Energy Management System
MPPT	Maximum Power Point Tracking	Maximum power point tracking
PID	Potential-Induced Degradation	Potential-induced degradation
Voc	Open-Circuit Voltage	open-circuit voltage
Anti PID	Anti-PID	Anti-PID
PID Recovery	PID Recovery	PID Recovery
PLC	Power-line Commucation	Power-line carrier communication
Modbus TCP/IP	Modbus Transmission Control / Internet Protocol	Modbus over TCP/IP
Modbus RTU	Modbus Remote Terminal Unit	Modbus over serial link
SCR	Short-Circuit Ratio	Short-circuit ratio
UPS	Uninterruptable Power Supply	Uninterruptible power supply
ECO mode	Economical Mode	Economic Mode
TOU	Time of Use	Time of use
ESS	Energy Stroage System	energy storage system
PCS	Power Conversion System	Power conversion system
RSD	Rapid shutdown	Rapid Shutdown
EPO	Emergency Power Off	Emergency Poweroff
SPD	Surge Protection Device	Lightning protection
ARC	zero injection/zero export Power Limit / Export Power Limit	Power Limit
DRED	Demand Response Enabling Device	Demand response enabling device
RCR	Ripple Control Receiver	-
AFCI	AFCI	AFCI DC arc-fault protection
GFCI	Ground Fault Circuit Interrupter	GFCI

Abbreviation	English Description	Chinese Description
RCMU	Residual Current Monitoring Unit	Residual current monitoring unit
FRT	Fault Ride Through	Fault ride-through
HVRT	High Voltage Ride Through	High voltage ride-through
LVRT	Low Voltage Ride Through	Low voltage ride-through
EMS	Energy Management System	Energy management system
BMS	Battery Management System	Battery management system
BMU	Battery Measure Unit	Battery measurement unit
BCU	Battery Control Unit	Battery control unit
SOC	State of Charge	State of charge
SOH	State of Health	State of health
SOE	State Of Energy	State of energy
SOP	State Of Power	State of power
SOF	State Of Function	State of function
SOS	State Of Safety	State of safety
DOD	Depth of discharge	depth of discharge

10.3 Explanation of Terms

- **Definition of Overvoltage Categories**
 - **Overvoltage Category I:** Equipment connected to circuits where measures are taken to limit transient overvoltages to a suitably low level.
 - **Overvoltage Category II:** Energy-consuming equipment supplied from a fixed electrical installation. This category includes appliances, portable tools, and other household and similar loads. If special requirements for reliability and suitability of such equipment exist, Overvoltage Category III applies.
 - **Overvoltage Category III:** Equipment in fixed electrical installations where special requirements for reliability and suitability must be met. This includes switching devices in fixed installations and industrial equipment permanently connected to fixed electrical installations.
 - **Overvoltage Category IV:** Equipment used at the origin of the electrical installation. This includes meters and primary overcurrent protection devices, etc.
- **Definition of Damp Location Categories**

Environmental Parameters	Level		
	3K3	4K2	4K4H
Temperature Range	0~+40°C	-33~+40°C	-33~+40°C
Humidity Range	5% to 85%	15% to 100%	4% to 100%

- **Definition of Environmental Categories:**
 - **Outdoor Inverter:** Ambient air temperature range from -25°C to +60°C, suitable for Pollution Degree 3 environments.
 - **Indoor Type II Inverter:** Ambient air temperature range from -25°C to +40°C, suitable for Pollution Degree 3 environments.
 - **Indoor Type I Inverter:** Ambient air temperature range from 0°C to +40°C, suitable for Pollution Degree 2 environments.
- **Definition of Pollution Degree Categories**
 - **Pollution Degree 1:** No pollution or only dry, non-conductive pollution.
 - **Pollution Degree 2:** Normally only non-conductive pollution occurs. Temporary conductivity caused by condensation must be expected occasionally.
 - **Pollution Degree 3:** Conductive pollution occurs, or dry non-conductive pollution becomes conductive due to condensation.
 - **Pollution Degree 4:** Persistent conductive pollution occurs, for example, due to conductive dust, rain, or snow.

10.4 Battery SN Code Meaning

*****2388*****



The 11th-14th digits

LXD10DSC0002

The 11th to 14th digits of the product SN code represent the production time code. The production date in the above image is 2023-08-08

- The 11th and 12th digits are the last two digits of the production year, e.g., 2023 is represented as 23;

- The 13th digit is the production month, e.g., August is represented as 8;
Details are as follows:

Month	Jan-Sep	Oct	Nov	Dec
Month Code	1~9	A	B	C

- The 14th digit is the production date, e.g., the 8th day is represented as 8;
Numbers are preferred for representation, e.g., 1~9 represent the 1st to 9th days,
A represents the 10th day, and so on. Among them, the letters I and O are not used
to avoid confusion. Details are as follows:

Production Day	1	2	3	4	5	6	7	8	9
Code	1	2	3	4	5	6	7	8	9

Production Date	10	11	12	13	14	15	16	17	18
Code	A	B	C	D	E	F	G	H	J

Production Date	21	22	23	24	25	26	27	28	29
Code	M	N	P	Q	R	S	T	U	V

11 Contact Information

GoodWe Technologies Co., Ltd.
90 Zijin Road, Suzhou New District, China
400-998-1212
www.goodwe.com
service@goodwe.com