



DE TECHNISCHE INFORMATION / MONTAGEANLEITUNG

Flachdach-Montagesystem TRIC F

EN TECHNICAL INFORMATION / INSTALLATION INSTRUCTIONS

Flat Roof Mounting System TRIC F

FR INFORMATIONS TECHNIQUE / INSTRUCTIONS DE MONTAGE

Système de montage pour toiture plate TRIC F

NL TECHNISCHE INFORMATIE / MONTAGEHANDLEIDING

Montagesysteem voor platte daken TRIC F

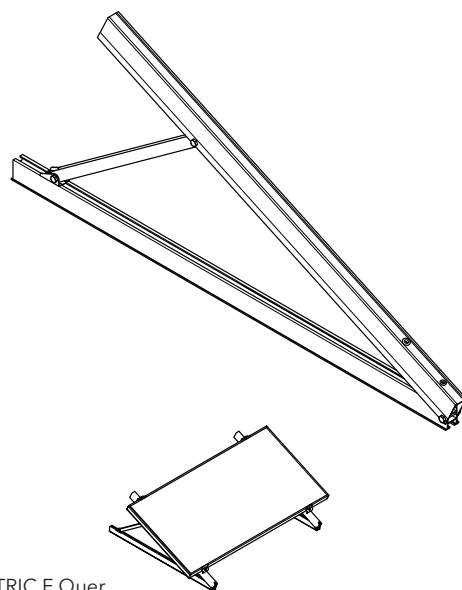
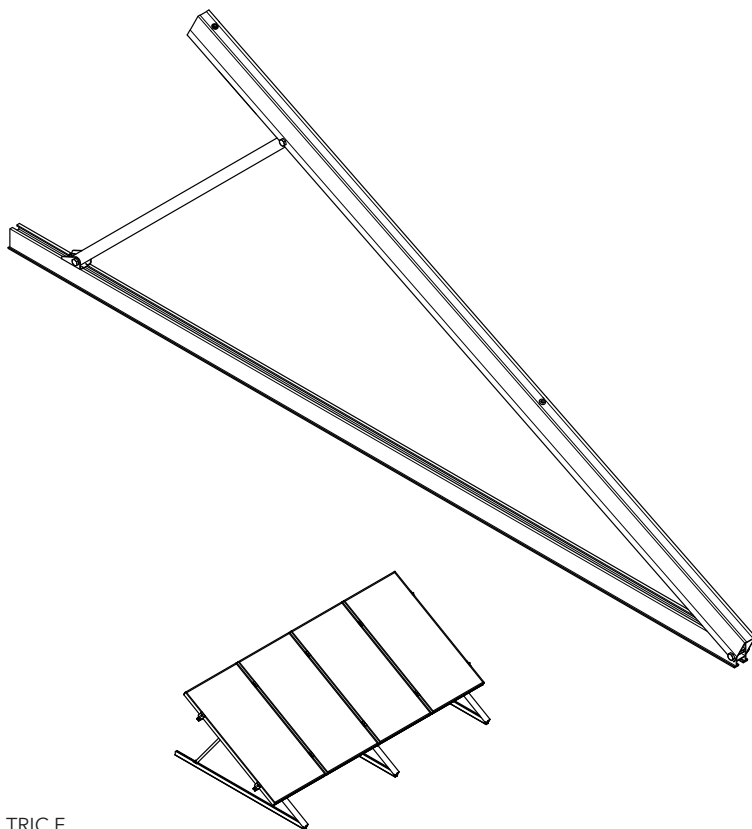

DE 1 Wichtige Hinweise

- Die Auslegung des Montagesystems (Anzahl der Montagedreiecke) ist projektbezogen entsprechend den vorgegeben Normen (DIN EN 1991-1-3 und DIN EN 1991-1-4:2010-12, Einwirkung auf Tragwerke - Allgemeine Einwirkungen - Schneelasten und Windlasten) durchzuführen.
- Voraussetzung für den bestimmungsgemäßen Einsatz ist immer ein geeigneter Befestigungsuntergrund, der die auftretenden Kräfte (Gewichtslast, Wind und Schneelast) aufnehmen kann.
- Die Montagevorschriften der Solarmodulhersteller sind einzuhalten.

EN 1 Important Notes

- The dimensioning of the mounting system (number of mounting triangles) should be specifically carried out for each individual project, following the specified structural engineering standards and regulations (EN 1991-1-3 and -1-4).
- Prerequisite for the proper application always is a solid mounting base that can accommodate the occurring forces (weight, wind and snow loads).
- The installation instructions of the solar module manufacturers must be adhered to.

FR 1 Notice importante

- Le dimensionnement du système de fixation (nombre des triangles d'appui) doit être calculé en fonction des données du projet et devra satisfaire aux normes spécifiés (EN 1991-1-3 et -1-4).
- Une structure de base appropriée pouvant résister aux efforts en présence (poids, vent et neige) représente la condition préalable au respect des normes.
- Respectez les instructions de montage du constructeur des modules solaires.

NL 1 Belangrijke aanwijzingen

- De configuratie van het montagesysteem (aantal dakankers, draagwijdte van de profielstangen) is projectgebonden volgens de geldige normen en voorschriften voor wind- en sneeuwlasten aan gebouwen, uit te voeren. (EN 1991 - 3 en EN 1991-1 - 4).
- Voorwaarde voor een reglementaire installatie is altijd een geschikte bevestigingsondergrond, die in staat is de optredende krachten (gewichtbelasting, wind- en sneeuwbelasting) op te vangen.
- De installateur moet zich houden aan de montagevoorschriften van de fabricant van de zonnepanelen.



Alle Maße in mm
All dimensions in mm
Toutes les dimensions sont en mm
Alle afmetingen in mm

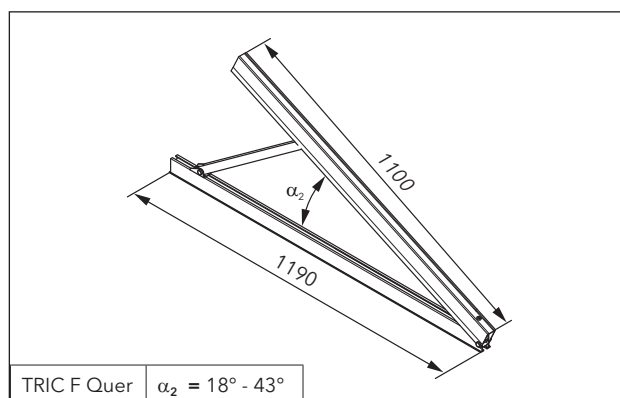
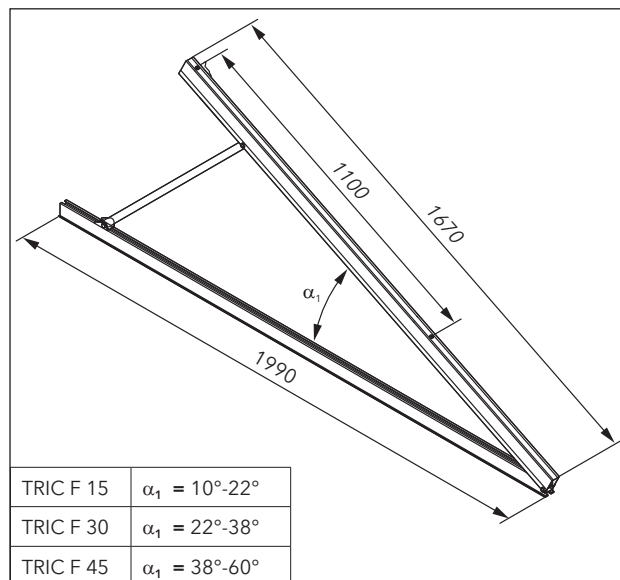

2 Montage / Mounting

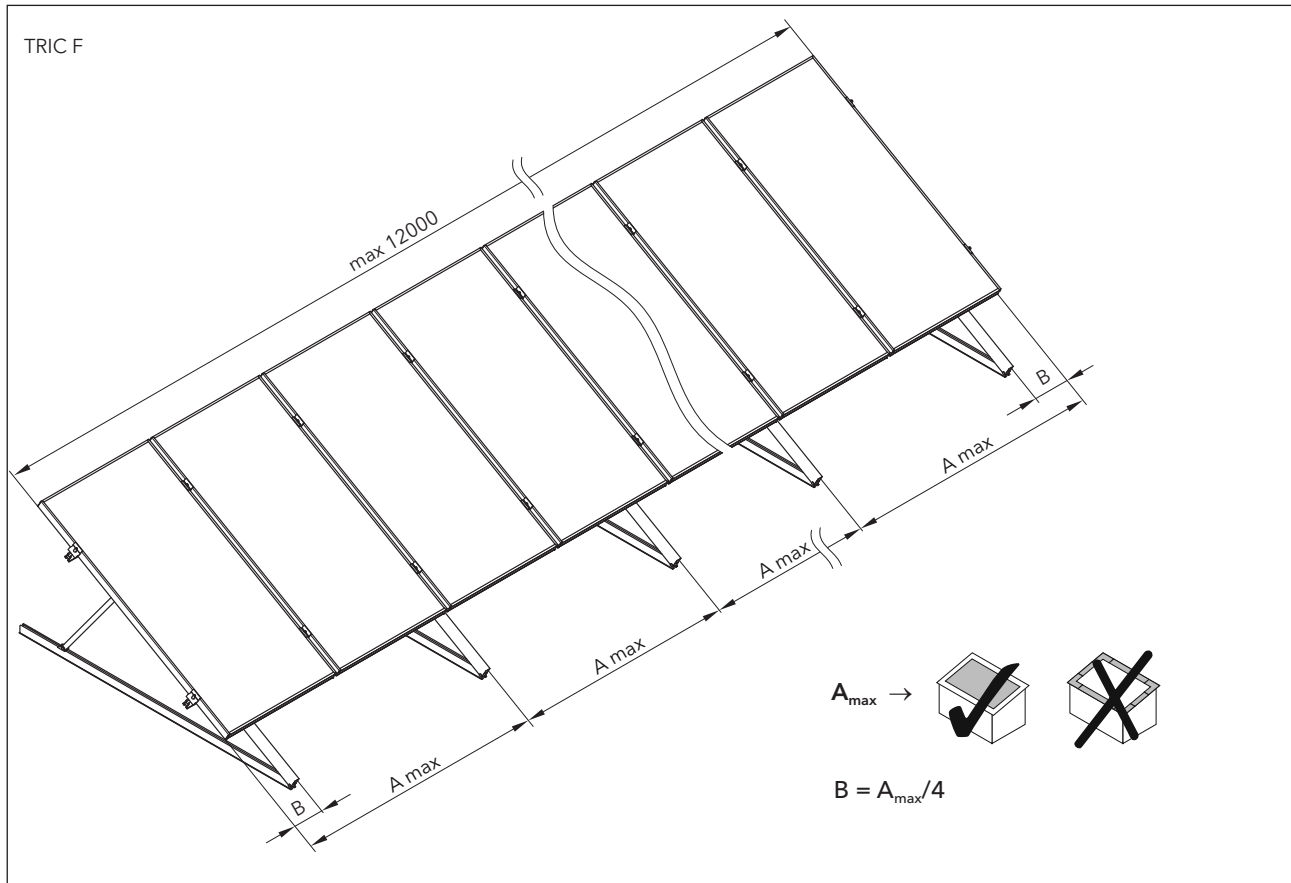

DE TRIC F: Max. zulässiger Abstand der Montagedreiecke

Höhe über NN		0 - 300 m	300 - 500 m	500 - 700 m	700 - 900 m
Schneelastzone	Windzone	A_{max} [mm]	A_{max} [mm]	A_{max} [mm]	A_{max} [mm]
1a	1	1.720	1.500	1.200	920
2	2	1.500	1.090	860	630
2	4	1.090	920	710	550
2a	2	1.330	1.000	710	520
3	2	1.200	860	630	460
3	4	1.000	750	570	410

TRIC F 30° / <10m

EN TRIC F: Max. tolerated distance between the triangle racks / Distance maximale entre les supports triangulaires / Max. toelaatbare afstand van de opstellingsdriehoeken

		H = 0 - 300 m		H = 300 - 500 m		H = 500 - 700 m		H = 700 - 900 m	
v_{ref} [m/s]	S_0 [kN/m ²]	A_{max} [mm]	S_0 [kN/m ²]	A_{max} [mm]	S_0 [kN/m ²]	A_{max} [mm]	S_0 [kN/m ²]	A_{max} [mm]	
22,5	0,81	1.720	1,04	1.500	1,63	1.200	2,37	920	
25,0	0,89	1.500	1,60	1.090	2,58	860	3,83	630	
30,0	0,89	1.090	1,60	920	2,58	710	3,83	550	
25,0	1,11	1.330	2,00	1.000	3,23	710	4,78	520	
25,0	1,29	1.200	2,37	860	3,86	630	5,76	460	
30,0	1,29	1.000	2,37	750	3,86	570	5,76	410	

TRIC F 30° / <10m

H = meters above sea level / mètres d'altitude / hoogte over de zeespiegel

v_{ref} = reference wind speed / vitesse de vent de référence / referentie windsnelheid

S_0 = ground snow load / charge de neige sur le sol / bodem sneeuwlast

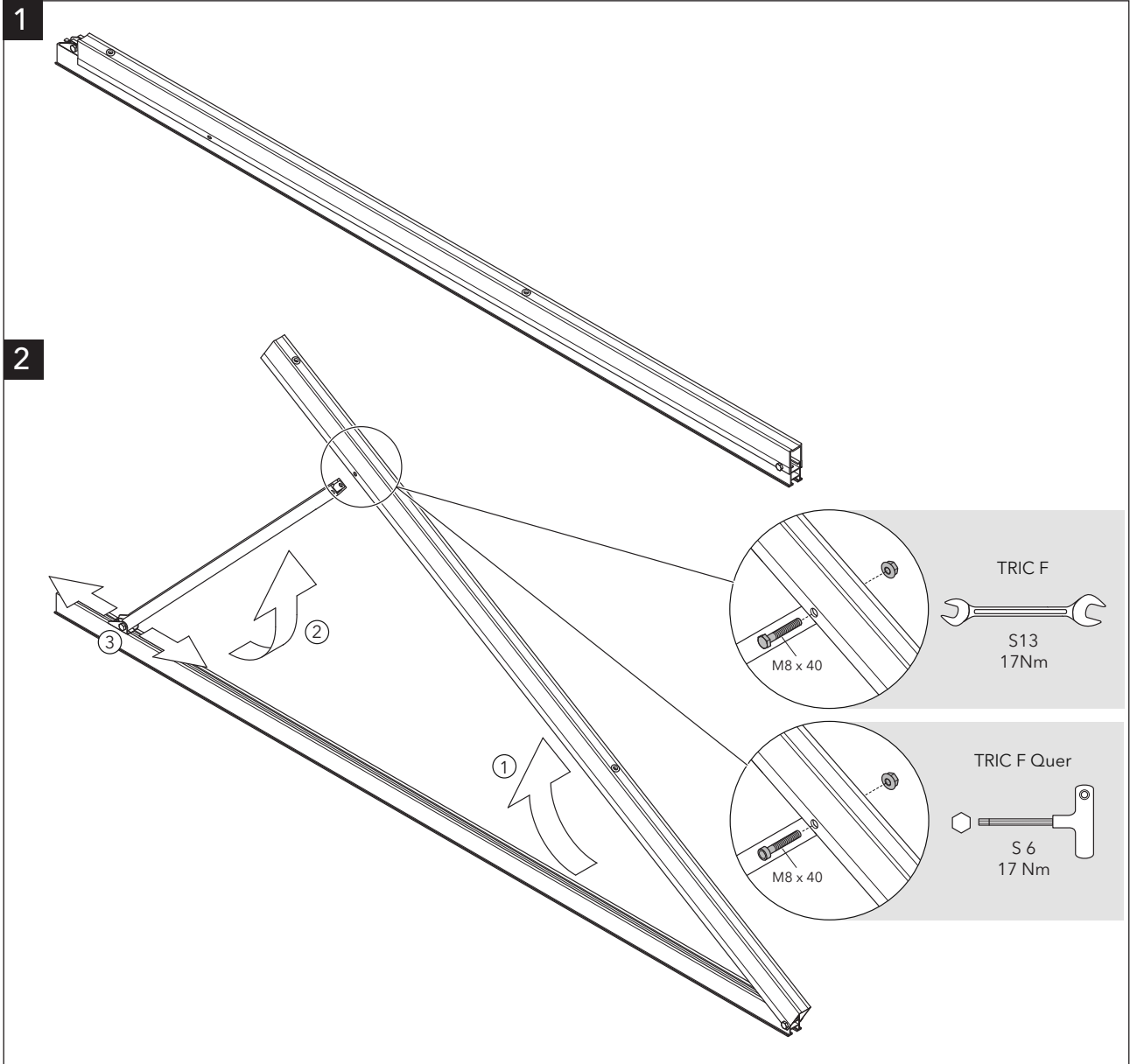

	α_1 [°]	C [mm]	B [mm]
TRIC F 15	10	168	500
	15	271	670
	20	464	820
TRIC F 30	25	105	970
	30	278	1.120
	35	525	1.250
TRIC F 45	40	89	1.378
	45	274	1.493
	50	486	1.597
	55	734	1.689
	60	1.071	1.768
TRIC F Quer	20	16	450
	25	79	540
	30	159	620
	35	261	700
	40	403	770

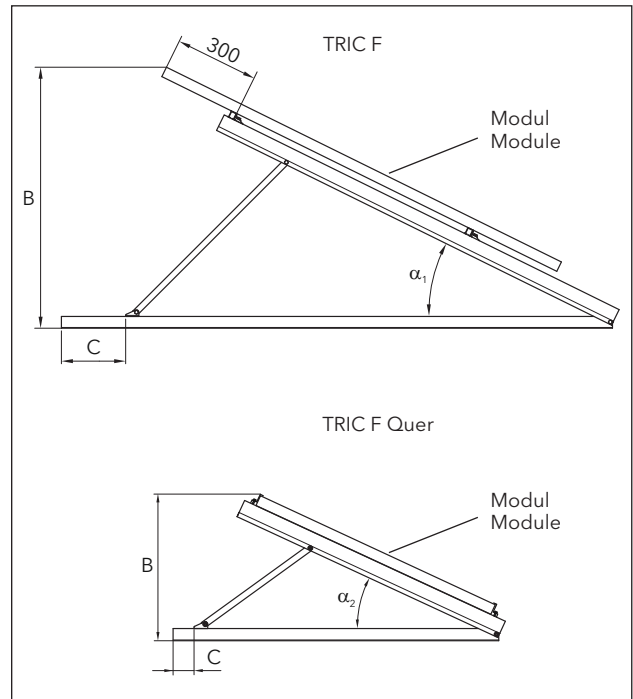

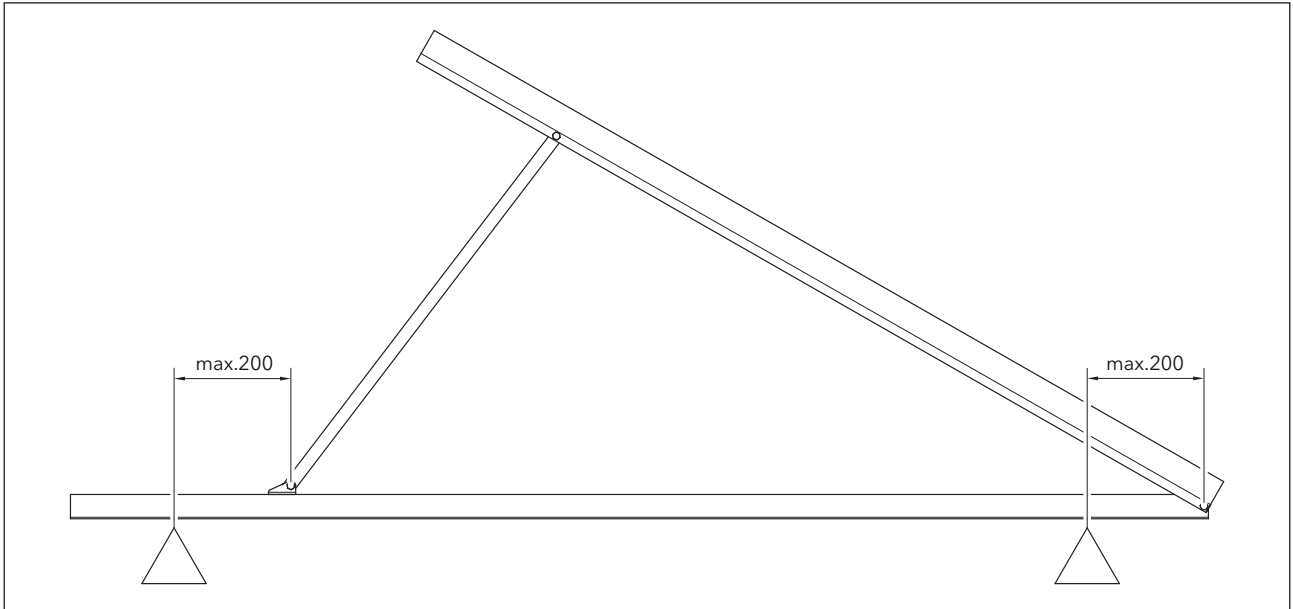

Montage auf Stahlträgern / Mounting on steel beams / Montage sur poutrelles d'acier / Montage op staalbalken

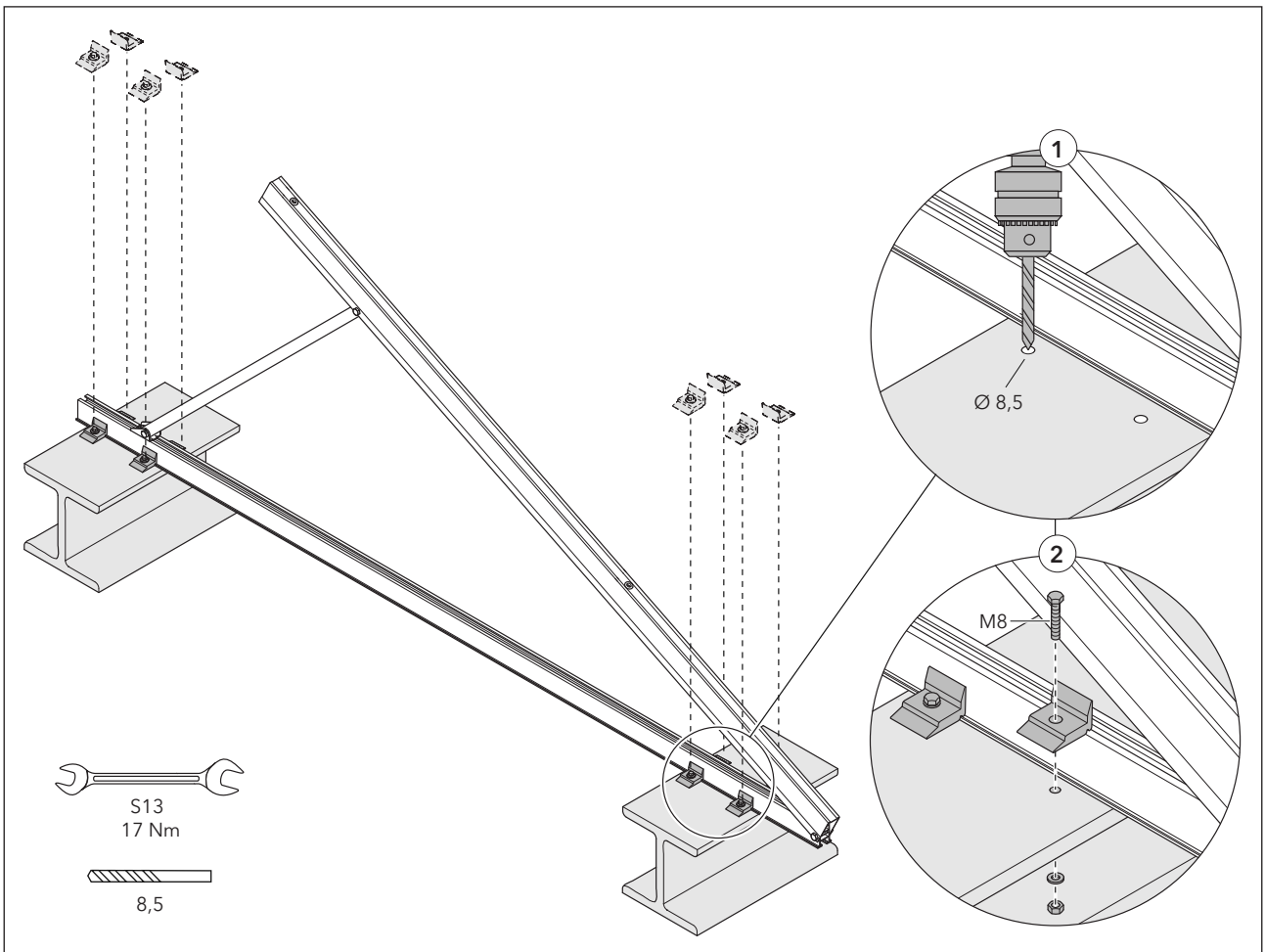

**Montage auf Ziegeldächern / Mounting on pan tiles / Montage sur toits en tuiles mécanique /
Montage op een pannendak**

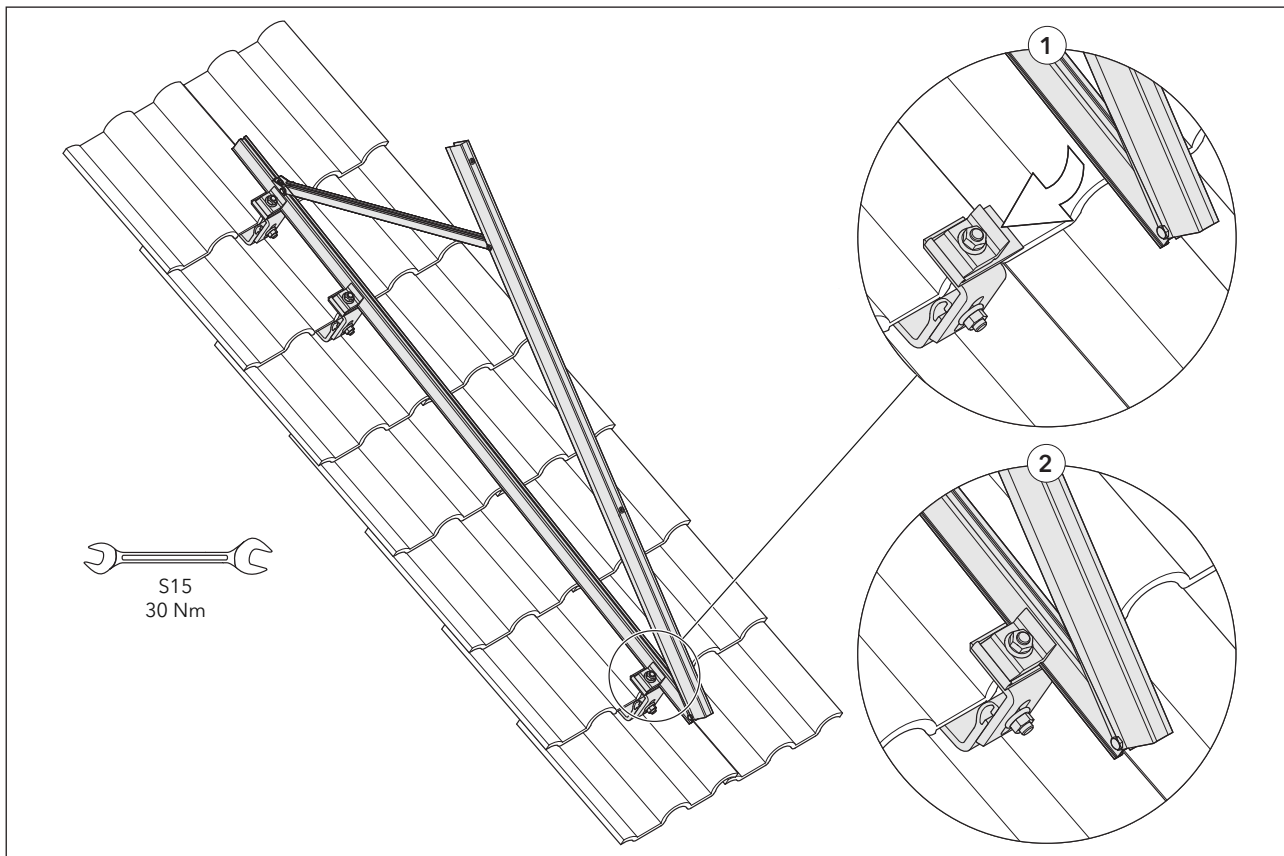

Montage auf Betonsteinen / Mounting on concrete bricks / Montage sur pavés en béton / Montage op betonblokken

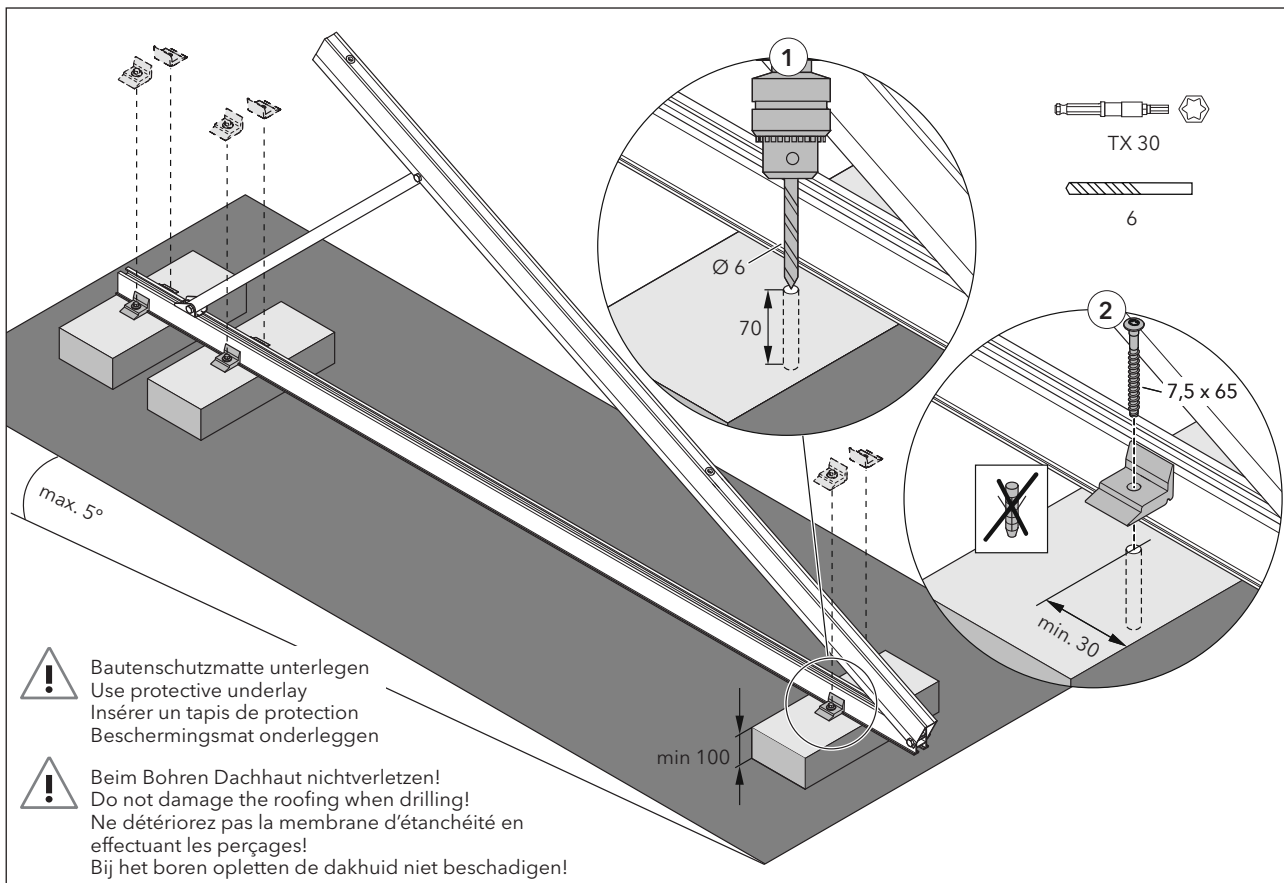

Montage auf Kiesplatten-Set / Mounting on gravel base plate set / Montage sur kit de plaques pour lestage / Montage op kiezelplaten

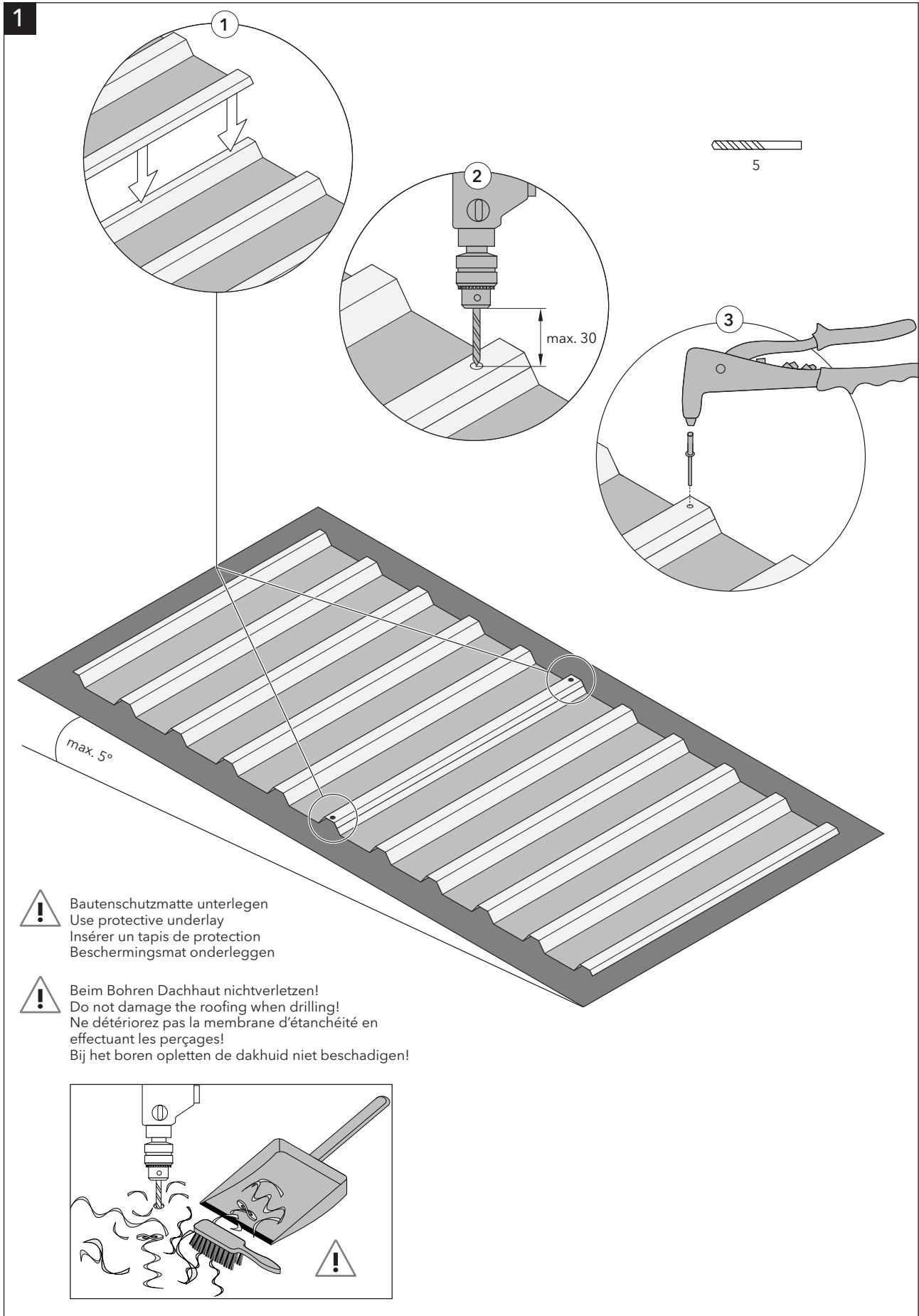

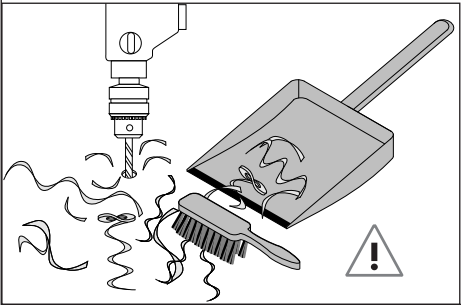
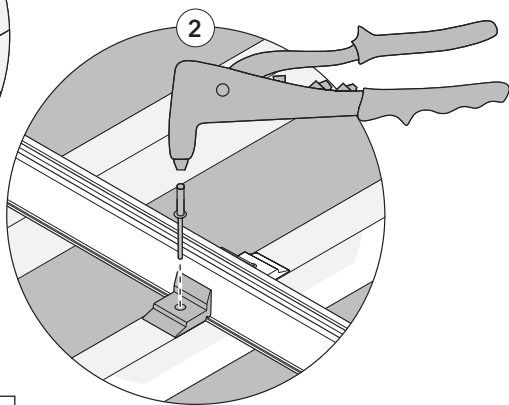
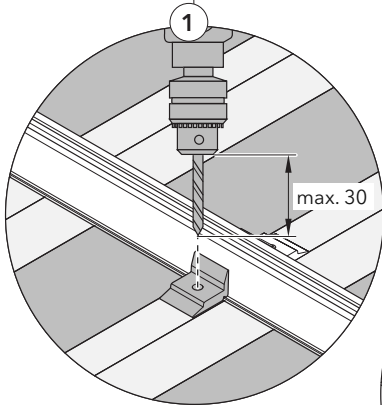
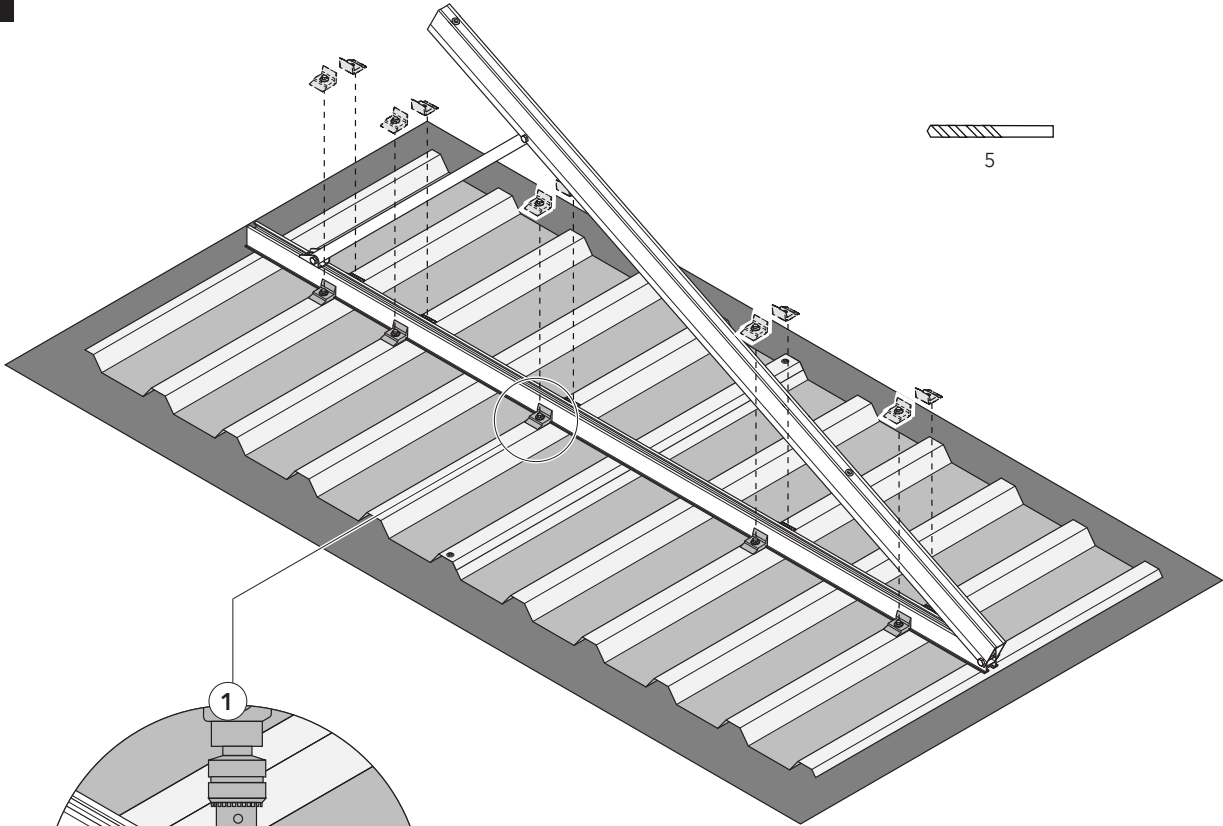

2

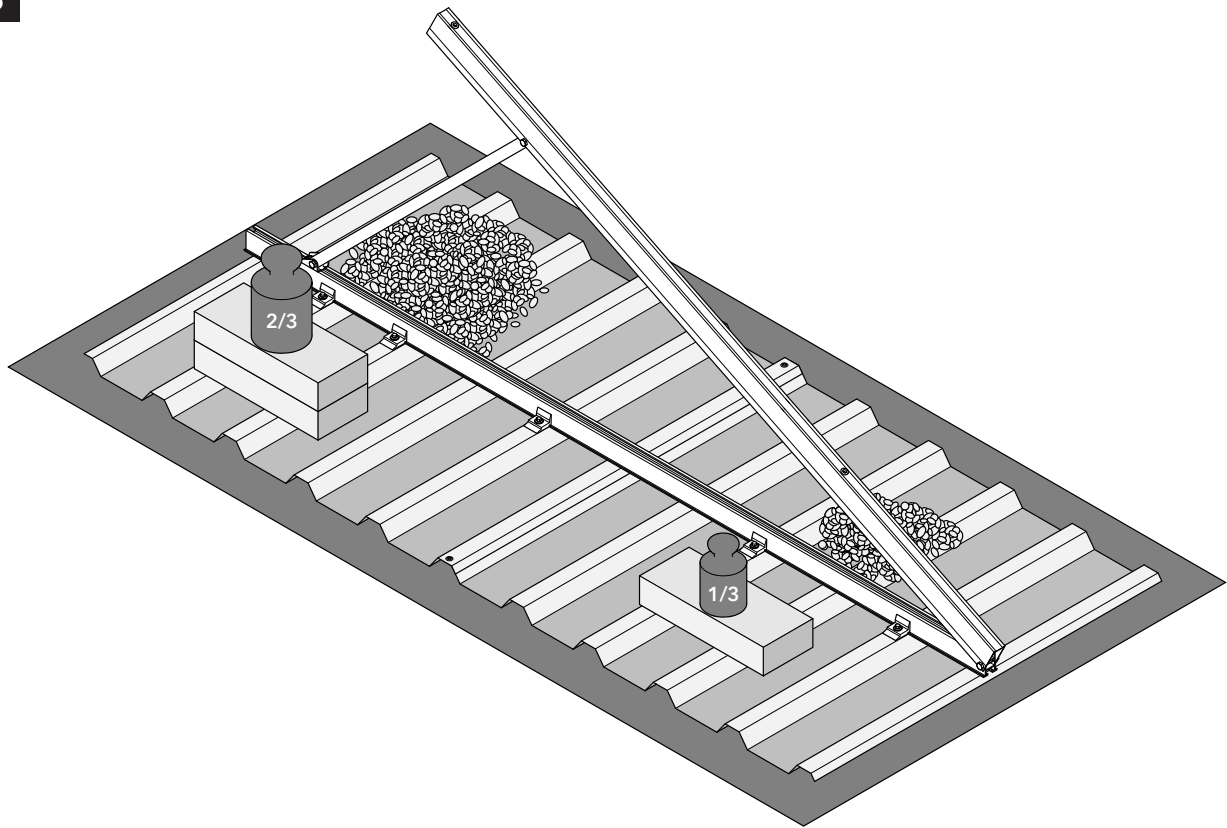

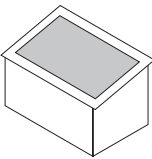
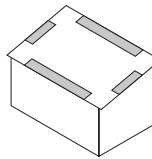
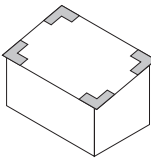

Auflastung (kg pro m² Modulfläche*) / Load (kg per m² module surface*) / Charge (kg par m² de surface de modules*) / Belasting (kg per m² module-oppervlakte*)

DE	EN FR NL			
Windzone	v _{ref} [m/s]	[kg]	[kg]	[kg]
1	22,5	105,0	172,5	232,5
2	25,0	135,0	217,5	285,0
3	27,5	172,5	270,0	352,5
4	30,0	210,0	330,0	427,5

TRIC F 30° /  < 10m /  < 800m (Binnenland / inland / à l'intérieur du pays / binnenland)

v_{ref} = reference wind speed / vitesse de vent de référence / referentie windsnelheid

* inkl. Sicherheitsbeiwerten nach DIN 1055-100

* incl. safety factor acc. to EN 1991

* incluant un coefficient de sécurité selon EN 1991

* incl. veiligheidscoëfficiënt volgens EN 1991

Montage quer zur Dachneigung / Mounting transverse to the roof pitch / Montage transversal par rapport à l'inclinaison du toit / Montage dwars ten optzichte van de dakhelling

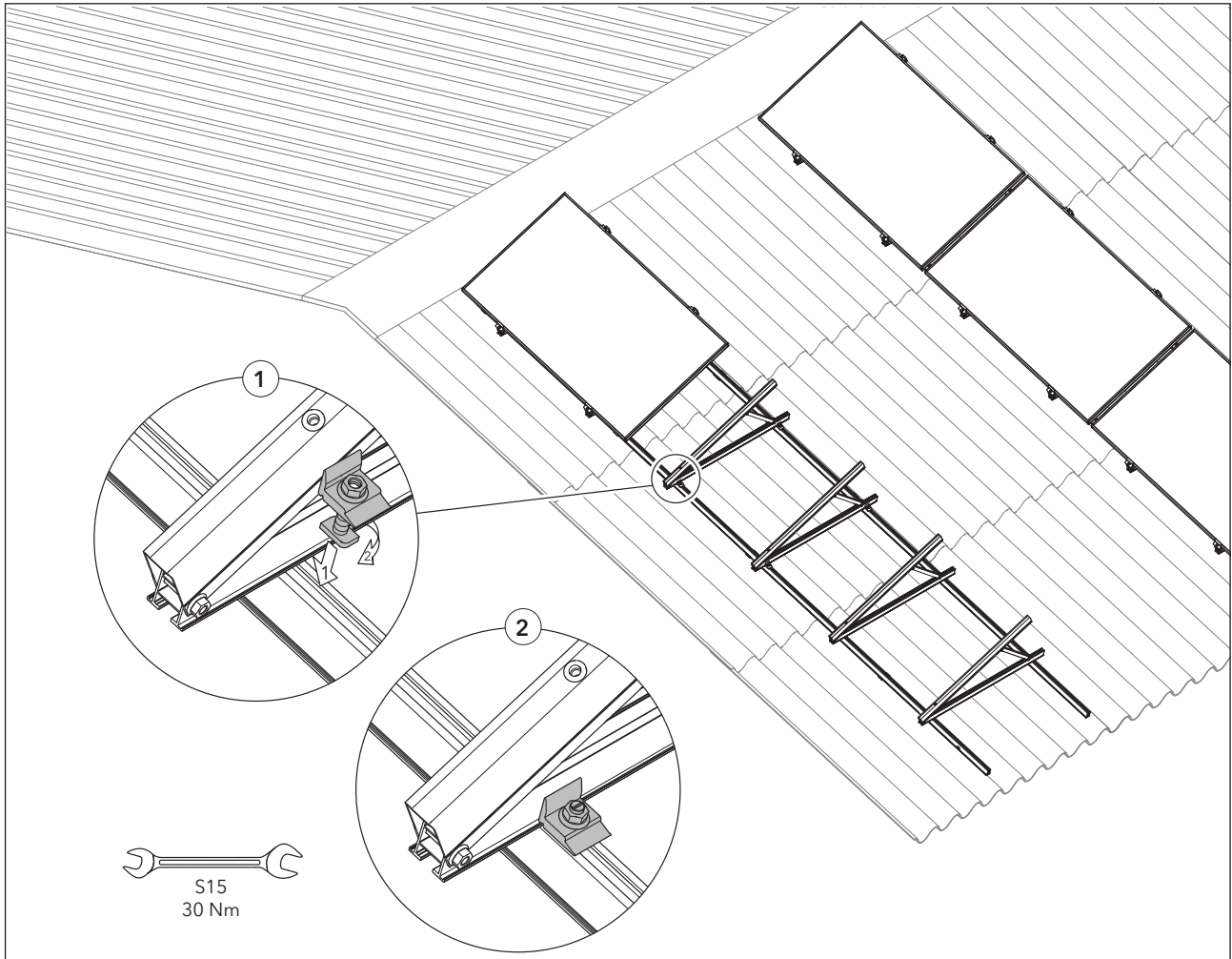

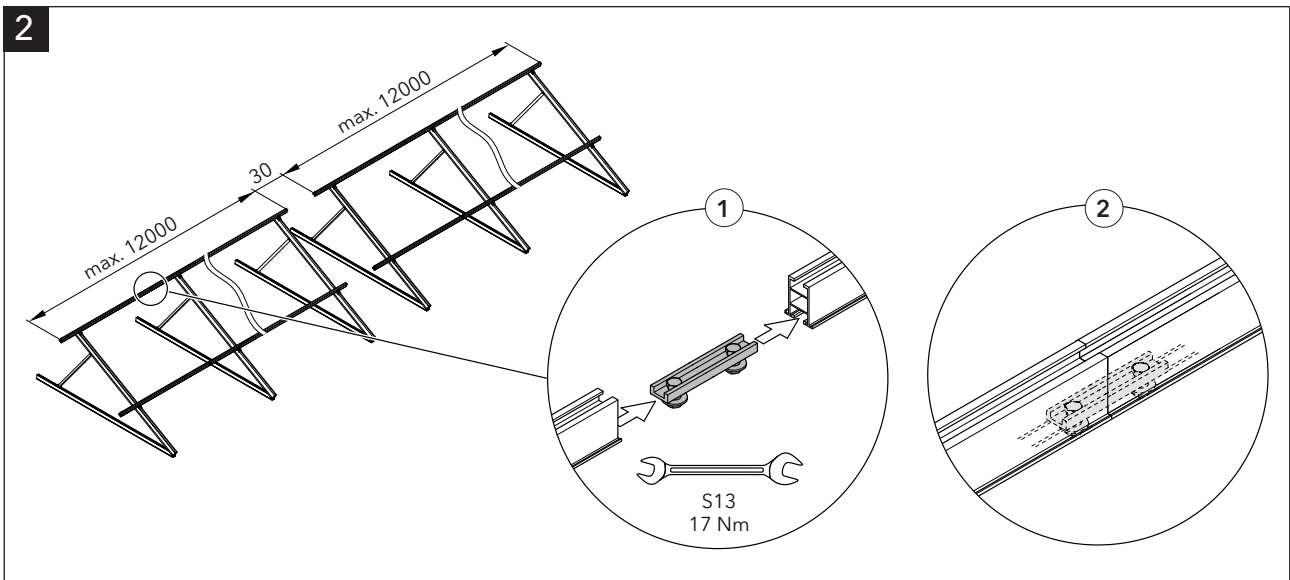
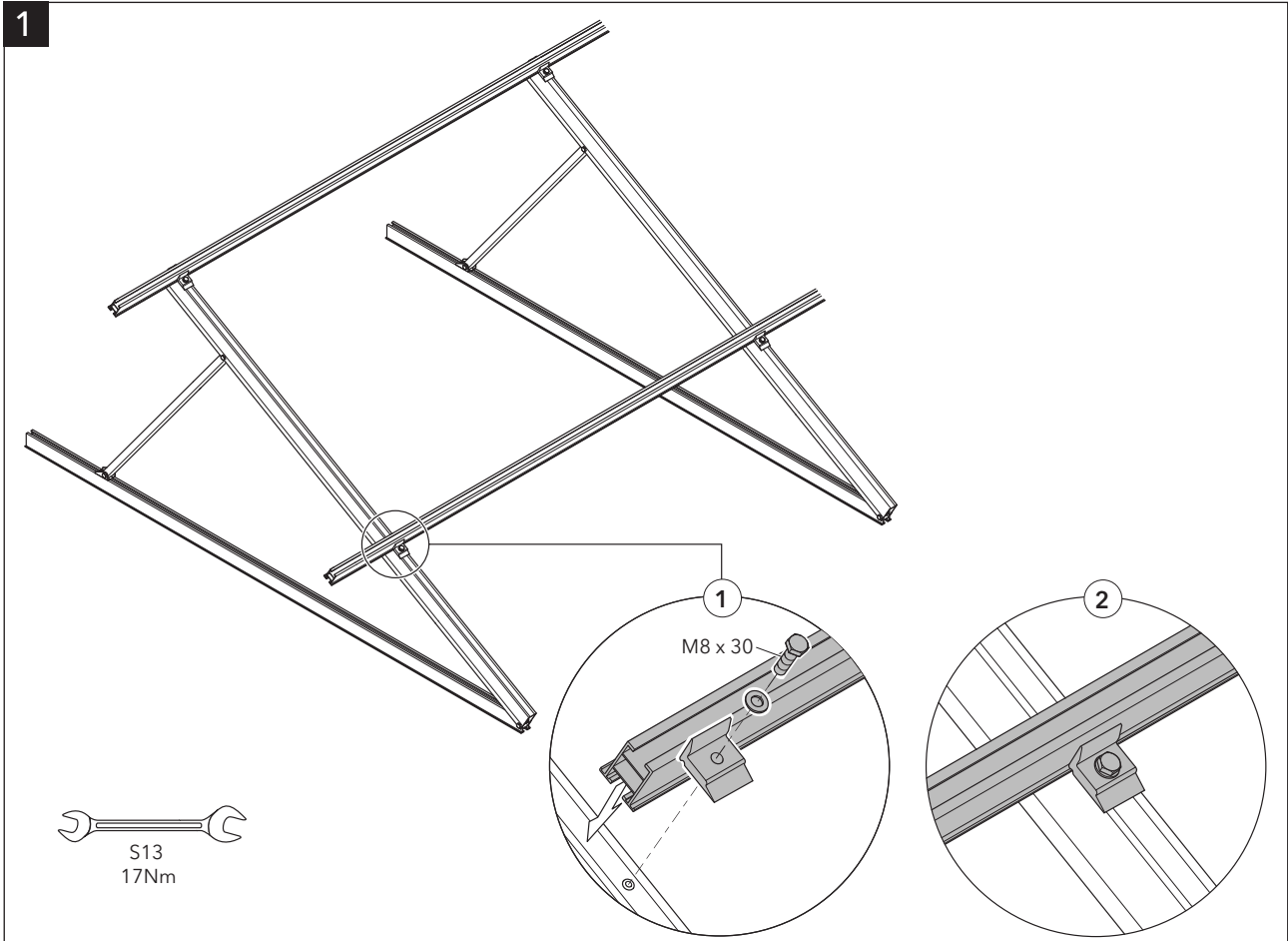

3

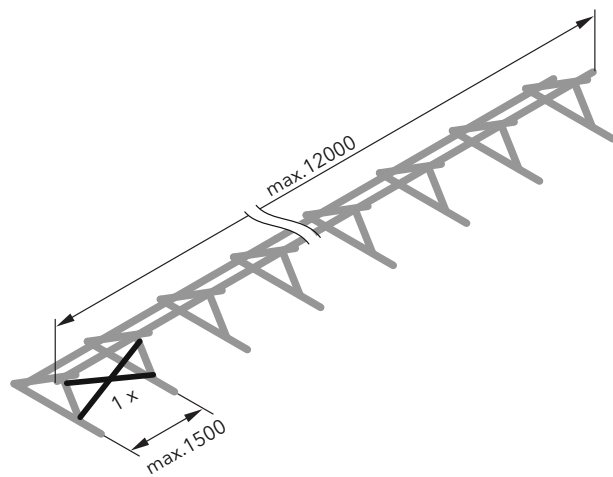
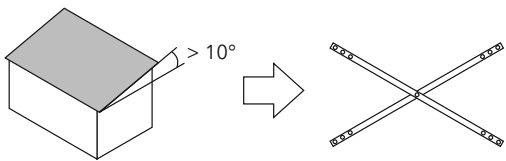

S13
17Nm

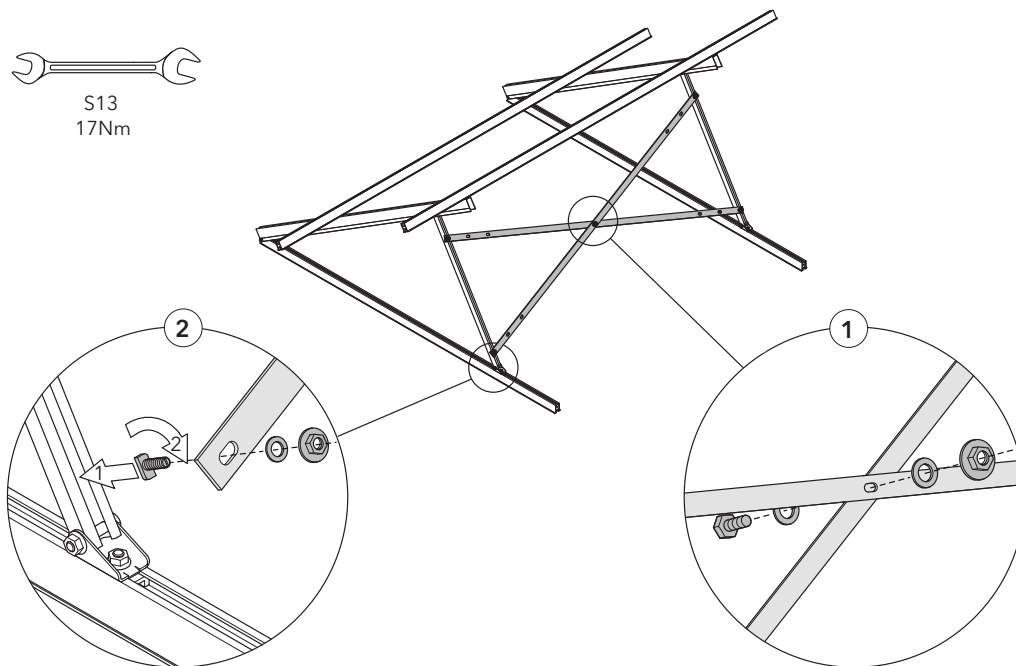

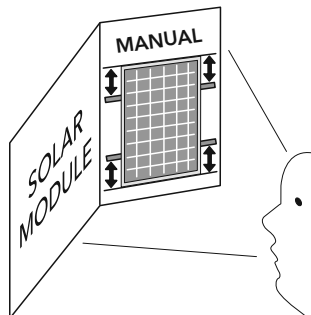
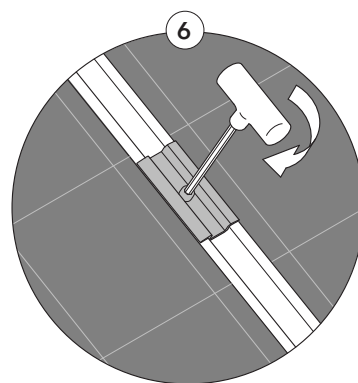
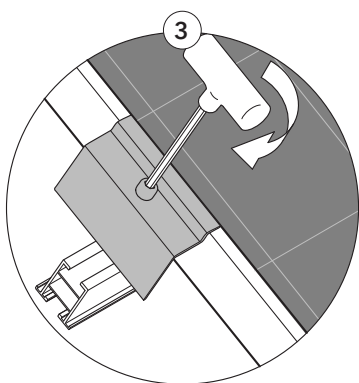
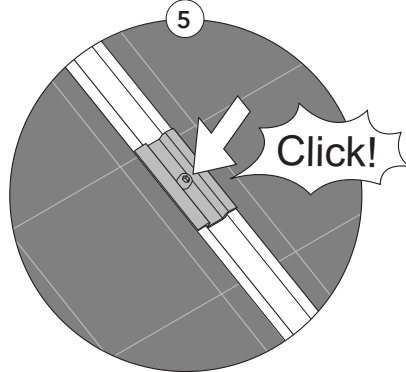
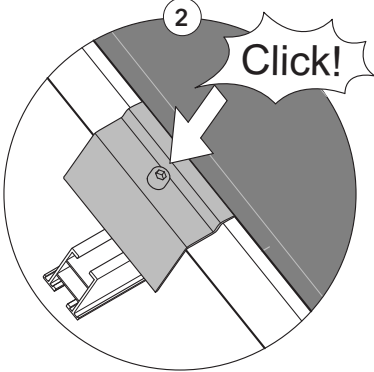
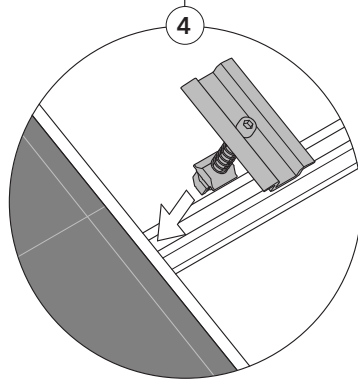
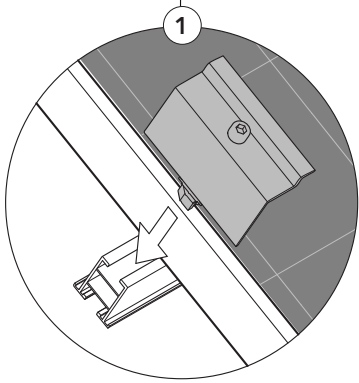
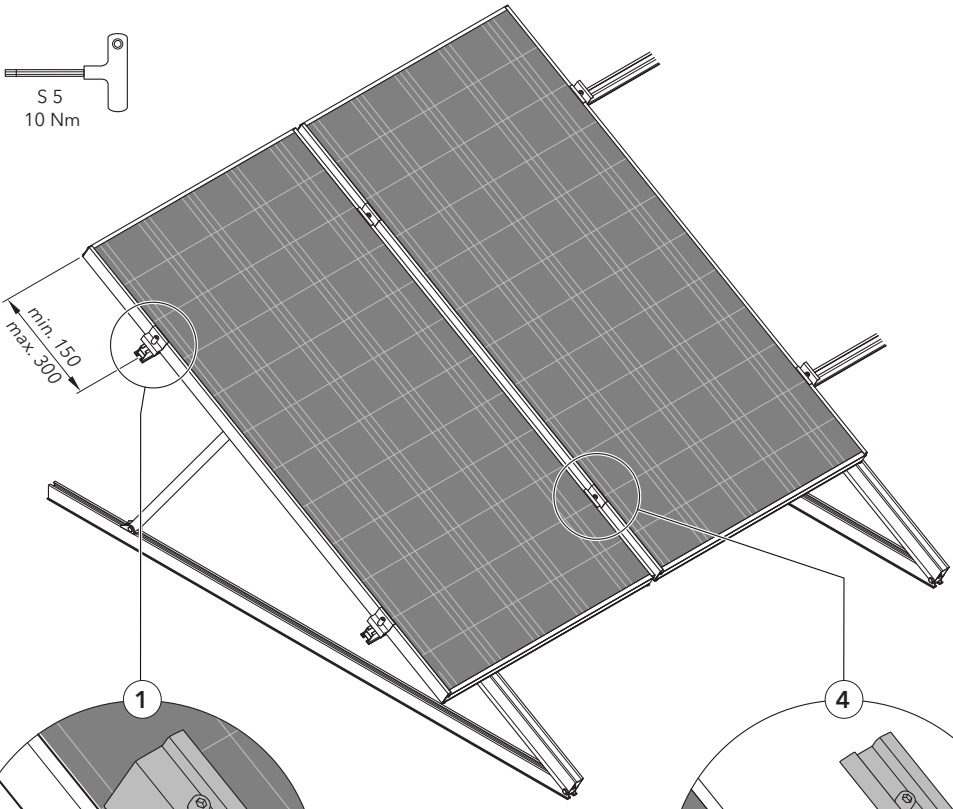
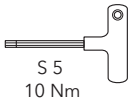

TRIC F Quer Modulmontage / Montage des modules / Horizontale montage van de modules

